

Hydrostatic Pump Repair

www.hydrostaticpumprepair.net

Phone: 800-361-0028

Email: sales@hydrostatic-transmission.com

ENGINEERING
TOMORROW

Danfoss

Data Sheet

MP1 Axial Piston Pumps

28/32 cm³, 38/45 cm³



For more than 40 years, Danfoss has been developing state-of-the-art components and systems for mobile machinery used in off-highway operations around the world. We have become a preferred supplier by offering the best of what really matters: The hardware inside your vehicle application.

The Future is here - MP1 Pumps. (MP1) This is just the beginning of a new generation of Danfoss pumps that will change the way you do business with Danfoss.

The MP1 pump has built off years of experience to capture the reliability, modularity and controllability of products you know well. Additionally the MP1 pump has added features while maintaining a competitive package size. The result is a pump that is fit for the future.

All controls related to electric options are PLUS+1[®] Compliant. PLUS+1[®] allows you to rapidly develop and customize electronic machine control.

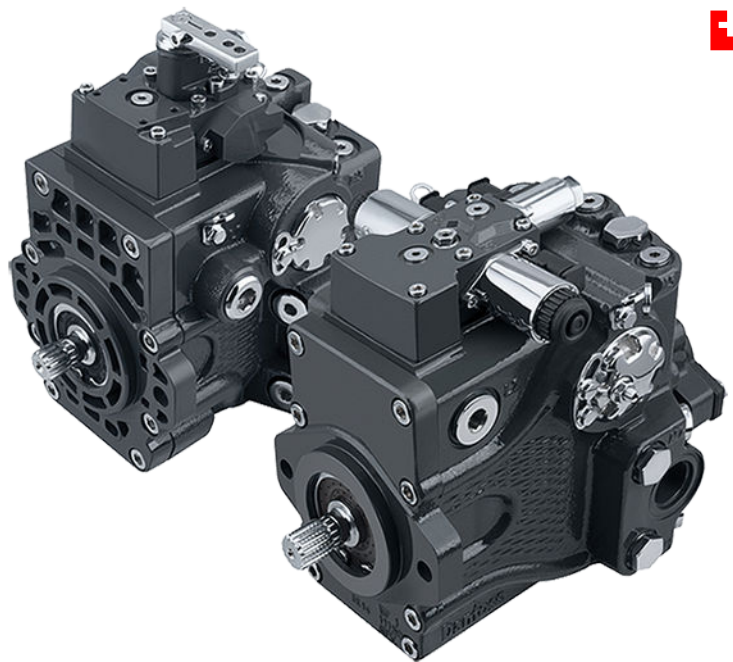

Features

Designed for Quality and Reliability

- Uniform design concept across frame sizes
- Single piece housing to minimize leaks
- Technologically advanced kit and servo system
- Predictable, low friction swashplate bearing for precise machine control

Machine Integration Benefits

- Industry leading pump length
- Clean side for easier machine integration
- Metric and Inch O-ring boss and Split flange (38/45 only) system port interfaces
- Standard connection interfaces

Greater Total Efficiency

- Increased pump efficiency
- Lower control pressure for less power consumption

Control Options

- Electro-hydraulic control options include
 - Electrical Displacement Control (EDC)
 - Forward-Neutral-Reverse (FNR)
 - Non-Feedback Proportional Electric (NFPE)
- Manual displacement control (MDC)
- Non-Feedback Proportional Hydraulic (NFPH)
- Common control across entire family

Expanded Functionality

- PLUS+1[®] Compliant control and options
- Easy integration with Telematics
- Integrated Flushing valve available (28/32 and 38/45)

Modularity

- Common control, charge pump and auxiliary pad options
- Easy and quick conversion to the right configuration

Comprehensive technical literature is online at www.danfoss.com

Technical Specification

Physical properties

Features	Unit	28	32	38	45
Displacement	cm ³	28.0	31.8	38.0	45.1
Weight (dry)	kg	29.6		38.0	

Operating parameters

Features		Unit	28/32	38/45
Input Speed	Minimum	min ⁻¹	500	500
	Rated		3400	3300
	Maximum		4000	3900
System Pressure	Max. working pressure*	bar	350	
	Max. pressure		380	
	Min. low loop		10	
Case Pressure	Rated	bar	3	
	Maximum		5	

Schematic

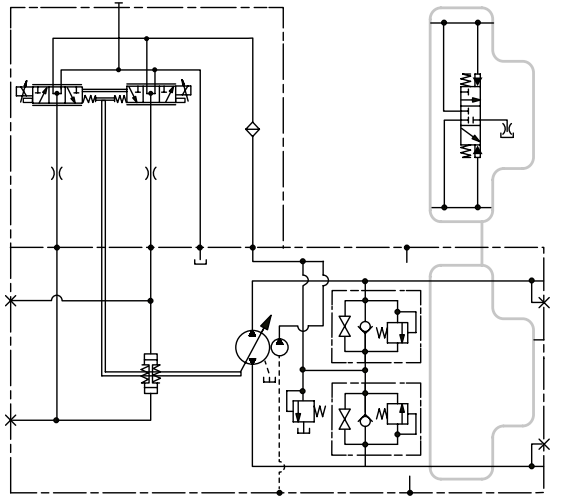

P400333

* Applied pressures above maximum working pressure requires Danfoss application approval.

Dimension

28/32 cm³

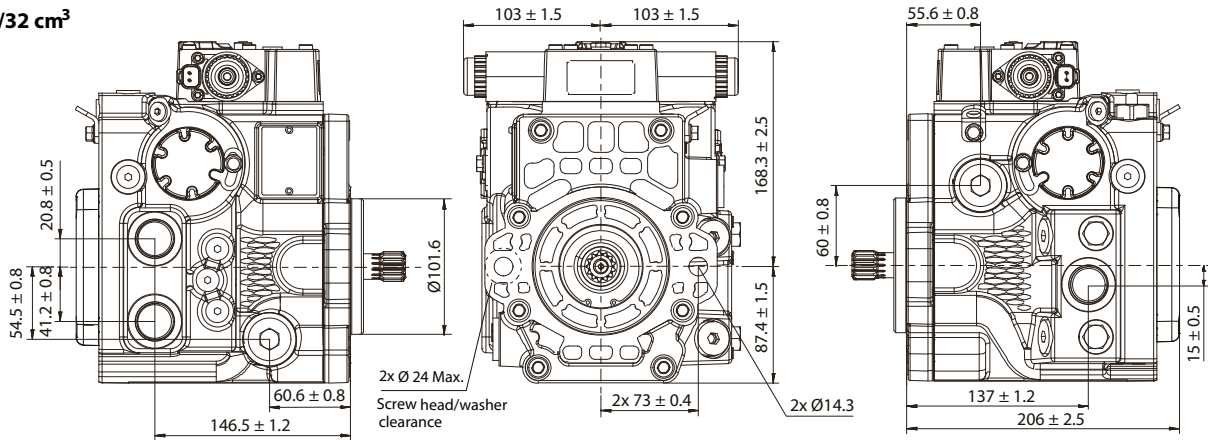

38/45 cm³

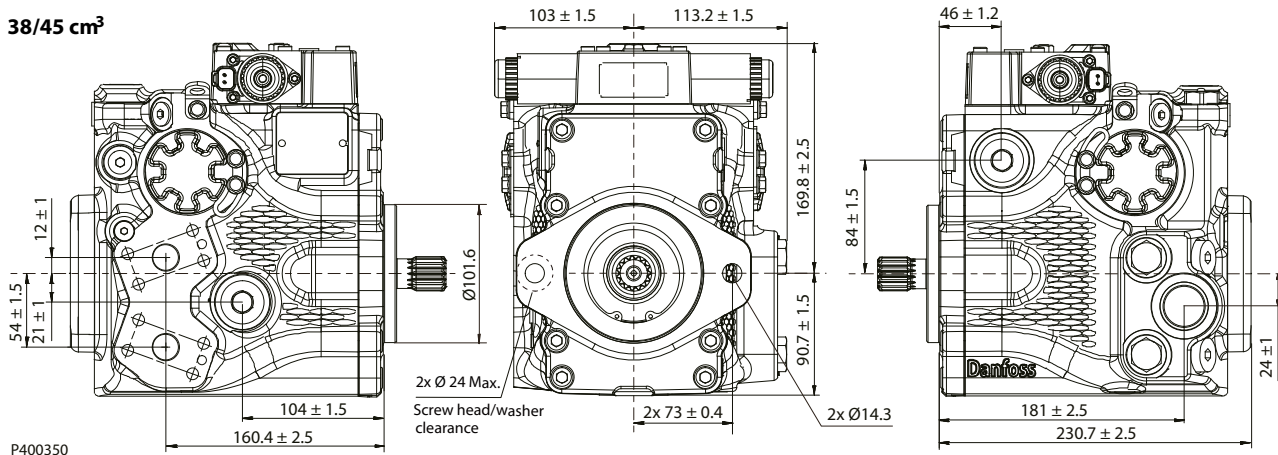

P400350

Danfoss can accept no responsibility for possible errors in catalogues, brochures and other printed material. Danfoss reserves the right to alter its products without notice. This also applies to products already on order provided that such alterations can be made without subsequent changes being necessary in specifications already agreed. All trademarks in this material are property of the respective companies. Danfoss and the Danfoss logotype are trademarks of Danfoss A/S. All rights reserved.