

# Hydrostatic Pump Repair

www.hydrostaticpumprepair.net

Phone: 800-361-0028

Email: sales@hydrostatic-transmission.com

## 10,000 Series

### Highlights

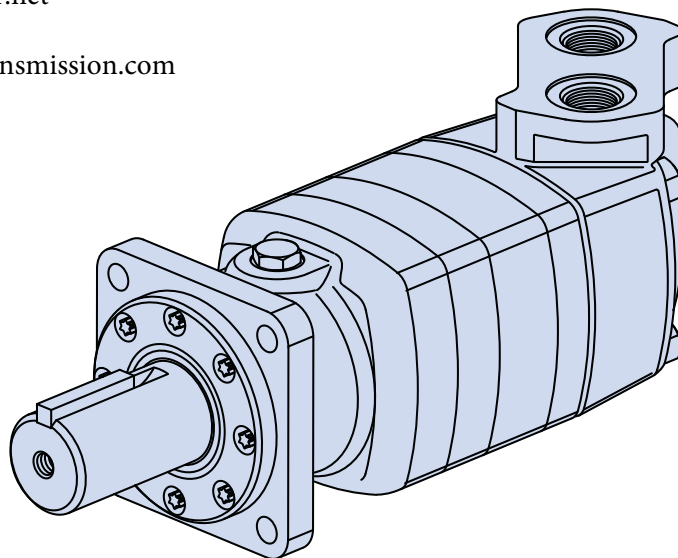

### Features

- High torque and flow
- Many options like 2 speed and speed sensors make this motor “smart”
- Low pressure loss even in higher flows

### Benefits

- High power density for demanding mobile and industrial applications
- Many options to draw from

### Applications

- Boring
- Industrial
- Metal Forming
- Port Equipment
- Saw Mill

### Description

This is the biggest disc valve motor of our line with up to 45 GPM and 24,000 in-lb of torque in continuous mode, this motor is powerful and yet provides good efficiency.

### Specifications

Geroler Element	4 Displacements
Flow l/min [GPM]	170 [45] Continuous**
	265 [70] Intermittent*
Speed RPM	501 Cont.**
	784 Inter.*
Pressure bar [PSI]	200 [3000] Cont.**
	270 [4000] Inter.*
Torque Nm [lb-in]	2700 [23910] Cont.**
	3440 [30460] Inter.*

\*\* Continuous—(Cont.) Continuous rating, motor may be run continuously at these ratings.

\* Intermittent—(Inter.) Intermittent operation, 10% of every minute.



Boring



Metal Forming



Port Equipment

# 10,000 Series

## Specifications

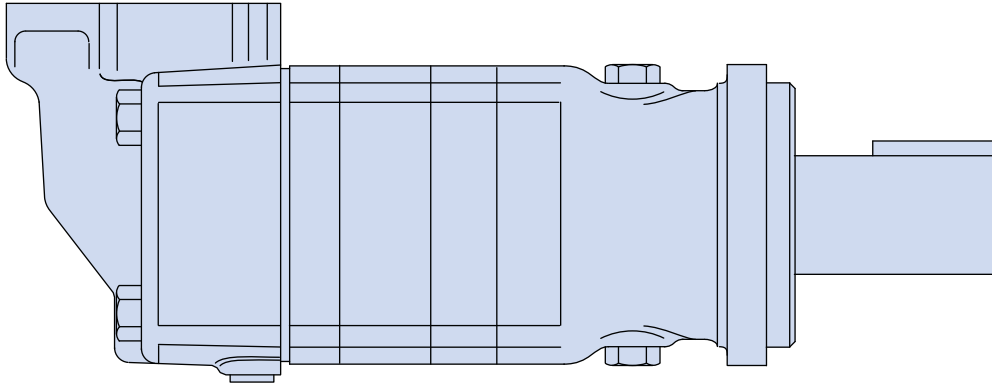

### 10,000 SERIES MOTORS

Displ. cm <sup>3</sup> /r [in <sup>3</sup> /r]		345 [21.0]	480 [29.3]	665 [40.6]	940 [57.4]
Max. Speed (RPM) @ Flow	Continuous	501	354	254	179
	Intermittent	784	552	396	279
Flow l/min [GPM]	Continuous	170 [45]	170 [45]	170 [45]	170 [45]
	Intermittent	265 [70]	265 [70]	265 [70]	265 [70]
Torque* Nm [lb-in]	Continuous	1040 [ 9220]	1475 [13050]	2085 [18450]	2700 [23910]
	Intermittent	1390 [12310]	1965 [17410]	2610 [23080]	3440 [30460]
Pressure Δ bar [Δ PSI]	Continuous	205 [3000]	205 [3000]	205 [3000]	190 [2750]
	Intermittent	275 [4000]	275 [4000]	260 [3750]	240 [3500]
	Peak	275 [4000]	275 [4000]	275 [4000]	260 [3750]
Weight kg [lb]	Standard or Wheel Mount	43,5 [96.0]	45,4 [100.0]	46,3 [100.0]	47,2 [104.0]
	Bearingless	31,3 [69.0]	33,1 [73.0]	33,1 [73.0]	34,9 [77.0]

\*See shaft torque ratings for limitations..

#### Note:

To assure best motor life, run motor for approximately one hour at 30% of rated pressure before application to full load. Be sure motor is filled with fluid prior to any load applications.

#### Maximum Inlet Pressure:

275 bar [4000 PSI]  
Do not exceed Δ pressure rating (see chart above).

#### Maximum Return Pressure:

275 bar [4000 PSI] with case drain line installed.  
Do not exceed Δ pressure rating (see chart above).

#### Maximum Case Pressure:

20 bar [300 PSI]

#### Δ bar [Δ PSI] :

The true pressure difference between inlet port and outlet port

#### Continuous Rating:

Motor may be run continuously at these ratings

#### Intermittent Operation:

10% of every minute

#### Peak Operation:

1% of every minute

#### Recommended Fluids:

Premium quality, anti-wear type hydraulic oil with a viscosity of not less than 70 SUS at operating temperature.

#### Recommended System Operating Temp.:

-34°C to 82°C [-30°F to 180°F]

#### Recommended Filtration:

per ISO Cleanliness Code, 4406: 20/18/13

# 10,000 Series

**345 cm<sup>3</sup>/r [21.0 in<sup>3</sup>/r]**  
 $\Delta$  Pressure Bar [PSI]

## Performance Data

Motors run with high efficiency in all areas designated with a number for torque and speed. For best motor life select a motor to run with a torque and speed range shown in the light shaded area.

Performance data is typical at 120 SUS. Actual data may vary slightly from unit to unit in production.

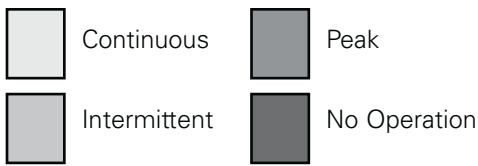

**480 cm<sup>3</sup>/r [29.3 in<sup>3</sup>/r]**  
 $\Delta$  Pressure Bar [PSI]

	[250] 15	[500] 35	[1000] 70	[1500] 105	[2000] 140	[2500] 170	[3000] 205	[3500] 240	[4000] 275
[1] 3.8	[760] 85 6	[1540] 175 5	[3120] 355 4	[4640] 525 2					
[2] 7.5	[1040] 120 15	[2140] 240 13	[4320] 490 11	[6500] 735 8	[8690] 980 5	[10870] 1230 2			
[4] 15	[1040] 120 31	[2130] 240 29	[4310] 485 27	[6490] 735 24	[8680] 980 21	[10860] 1225 18	[13050] 1475 16	[15230] 1720 13	[17410] 1965 10
[8] 30	[1020] 115 62	[2110] 240 61	[4290] 485 58	[6480] 730 55	[8660] 980 53	[10840] 1225 50	[13030] 1470 47	[15210] 1720 44	[17390] 1965 42
[12] 45	[990] 110 94	[2080] 235 93	[4270] 480 90	[6450] 730 87	[8630] 975 84	[10820] 1220 81	[13000] 1470 78	[15180] 1715 75	[17370] 1965 73
[16] 61	[960] 110 125	[2060] 235 124	[4240] 480 122	[6420] 725 119	[8600] 970 116	[10790] 1220 113	[12970] 1465 110	[15150] 1710 107	[17340] 1960 104
[20] 76	[930] 105 157	[2020] 230 156	[4200] 475 154	[6390] 720 150	[8570] 970 147	[10750] 1215 144	[12940] 1460 141	[15120] 1710 138	[17300] 1955 135
[24] 91	[890] 100 189	[1980] 225 188	[4170] 470 185	[6350] 715 182	[8530] 965 179	[10720] 1210 175	[12900] 1460 172	[15080] 1705 169	
[28] 106	[850] 95 221	[1940] 220 220	[4130] 465 217	[6310] 715 214	[8490] 960 210	[10680] 1205 207	[12860] 1455 203	[15040] 1700 200	
[32] 121	[810] 90 252	[1900] 215 251	[4080] 460 249	[6270] 710 245	[8450] 955 242	[10630] 1200 238	[12820] 1450 235	[15000] 1695 231	
[36] 136	[760] 85 282	[1850] 210 281	[4040] 455 280	[6220] 705 277	[8400] 950 273	[10590] 1195 270	[12770] 1445 266		
[40] 151	[710] 80 318	[1800] 205 316	[3990] 450 312	[6170] 695 308	[8350] 945 305	[10540] 1190 301	[12720] 1440 297		
[45] 170	[647] 75 354	[1740] 195 353	[3920] 445 351	[6110] 690 348	[8290] 935 344	[10470] 1185 340	[12660] 1430 336		
[60] 227	[430] 50 474	[1520] 170 473	[3710] 420 471	[5890] 665 467	[8070] 910 462	[10260] 1160 458	[12440] 1405 454		
[70] 265		[1360] 155 552	[3540] 400 550	[5730] 645 546	[7910] 895 541	[10100] 1140 536	[12280] 1385 532		

	[250] 15	[500] 35	[1000] 70	[1500] 105	[2000] 140	[2500] 170	[3000] 205	[3500] 240	[4000] 275
[1] 3.8	[600] 70 3	[1310] 150 1							
[2] 7.5	[740] 85 21	[1510] 170 19	[3050] 345 15	[4600] 520 11	[6140] 695 8	[7680] 865 4			
[4] 15	[730] 80 43	[1500] 170 41	[3040] 345 37	[4590] 520 33	[6140] 695 30	[7680] 870 26	[9220] 1040 22	[10770] 1215 18	[12310] 1390 14
[8] 30	[720] 80 87	[1490] 170 86	[3030] 340 82	[4580] 515 78	[6120] 690 74	[7670] 865 70	[9210] 1040 66	[10750] 1215 62	[12300] 1390 58
[12] 45	[700] 80 131	[1470] 165 130	[3020] 340 127	[4560] 515 123	[6100] 690 118	[7650] 865 114	[9190] 1040 110	[10740] 1215 106	[12280] 1385 102
[16] 61	[680] 75 176	[1450] 165 175	[3000] 340 172	[4540] 515 167	[6080] 685 163	[7630] 860 158	[9170] 1035 154	[10720] 1210 149	[12260] 1385 145
[20] 76	[660] 75 221	[1430] 160 220	[2970] 335 217	[4520] 510 212	[6060] 685 207	[7600] 860 202	[9150] 1035 198	[10690] 1205 193	[12230] 1380 189
[24] 91	[630] 70 266	[1400] 160 265	[2950] 335 261	[4490] 505 256	[6030] 680 252	[7580] 855 246	[9120] 1030 242	[10660] 1205 237	[12210] 1380 232
[28] 106	[600] 70 310	[1370] 155 309	[2920] 330 306	[4460] 505 301	[6000] 680 296	[7550] 855 291	[9090] 1025 286	[10640] 1200 280	[12180] 1375 275
[32] 121	[570] 65 356	[1340] 150 355	[2890] 325 351	[4430] 500 346	[5970] 675 340	[7520] 850 335	[9060] 1025 329	[10610] 1200 324	[12150] 1370 319
[36] 136	[540] 60 400	[1310] 150 399	[2850] 320 396	[4400] 495 390	[5940] 670 384	[7480] 845 379	[9030] 1020 373	[10570] 1195 368	[12120] 1370 362
[40] 151	[500] 55 445	[1270] 145 444	[2820] 320 441	[4360] 495 435	[5910] 670 429	[7450] 840 423	[8990] 1015 417	[10540] 1190 412	
[45] 170	[460] 50 501	[1220] 140 500	[2760] 310 498	[4300] 485 492	[5840] 660 486	[7380] 835 480	[8910] 1005 473	[10450] 1180 467	
[60] 227		[1080] 130 668	[2620] 295 665	[4160] 470 658	[5710] 645 651	[7250] 820 644	[8800] 995 637		
[70] 265		[960] 110 784	[2510] 285 777	[4050] 460 769	[5590] 630 761	[7140] 805 754	[8680] 980 746		

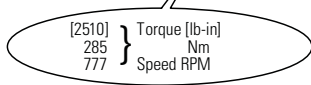

# 10,000 Series

## Performance Data

Motors run with high efficiency in all areas designated with a number for torque and speed. For best motor life select a motor to run with a torque and speed range shown in the light shaded area.

Performance data is typical at 120 SUS. Actual data may vary slightly from unit to unit in production.

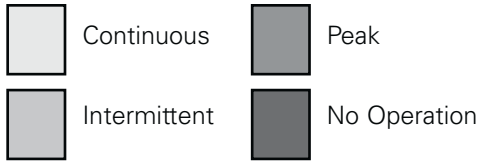

### 665 cm<sup>3</sup>/r [40.6 in<sup>3</sup>/r] Pressure Bar [PSI]

	[250] 15	[500] 35	[750] 50	[1000] 70	[1250] 85	[1500] 105	[1750] 120	[2000] 140	[2250] 155	[2500] 170	[2750] 190	[3000] 205	[3250] 225	[3500] 240	[3750] 260
[1] 3.8	[1470] 165 4	[3010] 340 3	[4550] 515 3	[6100] 690 2	[7630] 860 1										
[2] 7.5	[1480] 165 10	[3020] 340 9	[4560] 515 8	[6110] 690 7	[7650] 865 7	[9200] 1040 6	[10740] 1215 5	[12280] 1385 4	[13830] 1565 3	[15370] 1735 2	[16910] 1910 1				
[4] 15	[1470] 165 22	[3010] 340 21	[4550] 515 20	[6100] 690 19	[7640] 865 18	[9190] 1040 17	[10730] 1210 16	[12270] 1385 15	[13820] 1560 14	[15360] 1730 13	[16900] 1910 12	[18450] 2085 11	[19990] 2260 10	[21540] 2435 9	[23080] 2610 8
[8] 30	[1440] 165 44	[2980] 335 43	[4530] 510 42	[6070] 685 41	[7610] 860 40	[9160] 1035 39	[10700] 1210 38	[12250] 1385 37	[13790] 1560 36	[15330] 1730 35	[16880] 1905 34	[18420] 2080 33	[19960] 2255 32	[21510] 2430 31	[23050] 2605 30
[12] 45	[1400] 160 67	[2950] 335 66	[4490] 505 65	[6040] 680 64	[7580] 855 63	[9120] 1030 62	[10670] 1205 61	[12210] 1380 60	[13750] 1555 59	[15300] 1730 58	[16840] 1905 57	[18380] 2075 56	[19930] 2250 55	[21470] 2425 54	[23020] 2600 53
[16] 61	[1360] 155 89	[2910] 330 88	[4450] 505 87	[5990] 675 86	[7530] 850 85	[9080] 1025 84	[10620] 1200 83	[12170] 1375 82	[13710] 1550 81	[15260] 1725 80	[16800] 1900 79	[18340] 2070 78	[19890] 2245 77	[21440] 2420 76	
[20] 76	[1310] 150 112	[2860] 375 111	[4400] 495 110	[5940] 670 109	[7490] 845 108	[9030] 1020 107	[10580] 1195 106	[12120] 1370 105	[13660] 1545 104	[15210] 1720 103	[16750] 1890 102	[18300] 2070 101	[19840] 2240 99		
[24] 91	[1260] 140 135	[2800] 315 134	[4350] 490 132	[5890] 665 131	[7440] 840 130	[8980] 1015 129	[10520] 1190 128	[12070] 1365 127	[13610] 1540 126	[15150] 1720 125	[16700] 1890 124	[18240] 2060 123			
[28] 106	[1200] 135 157	[2750] 310 156	[4290] 485 155	[5840] 660 154	[7380] 835 153	[8920] 1010 151	[10470] 1185 150	[12010] 1355 149	[13550] 1530 148	[15100] 1705 147	[16640] 1880 146				
[32] 121	[1140] 130 180	[2690] 305 179	[4230] 480 177	[5770] 650 176	[7320] 825 175	[8860] 1000 174	[10400] 1175 173	[11950] 1350 172	[13490] 1525 171	[15040] 1700 169	[16580] 1875 168				
[36] 136	[1080] 120 202	[2620] 295 201	[4160] 470 200	[5710] 645 199	[7250] 820 198	[8800] 995 196	[10340] 1170 195	[11880] 1340 194	[13430] 1515 193	[14970] 1690 191	[16510] 1865 190				
[40] 151	[1010] 115 225	[2550] 290 224	[4100] 465 222	[5640] 635 221	[7180] 810 220	[8730] 985 219	[10270] 1160 217	[11810] 1350 216	[13360] 1500 215	[14900] 1675 214	[16440] 1850 212				
[45] 170	[920] 105 254	[2460] 280 252	[4000] 450 251	[5550] 625 249	[7090] 800 248	[8630] 975 247	[10180] 1150 245	[11720] 1325 244	[13260] 1500 243	[14810] 1675 242					
[60] 227	[610] 70 338	[2150] 245 336	[3700] 420 335	[5240] 590 334	[6780] 765 332	[8330] 940 331	[9870] 1115 329	[11420] 1290 328	[12960] 1465 327						
[70] 265	[380] 45 396	[1930] 220 393	[3470] 390 391	[5010] 565 390	[6560] 740 388	[8100] 915 387	[9640] 1090 385	[11190] 1265 384							



### 940 cm<sup>3</sup>/r [57.4 in<sup>3</sup>/r] Pressure Bar [PSI]

	[250] 15	[500] 35	[750] 50	[1000] 70	[1250] 85	[1500] 105	[1750] 120	[2000] 140	[2250] 155	[2500] 170	[2750] 190	[3000] 205	[3250] 225	[3500] 240
[1] 3.8	[2080] 235 3	[4260] 480 2	[6440] 730 1											
[2] 7.5	[2090] 235 7	[4270] 480 6	[6450] 730 5	[8640] 975 4	[10820] 1220 3	[13000] 1470 2	[15190] 1715 1	[17370] 1965 1						
[4] 15	[2080] 235 15	[4260] 480 14	[6440] 730 13	[8620] 975 13	[10810] 1220 12	[12990] 1470 11	[15170] 1715 10	[17360] 1960 9	[19540] 2210 8	[21720] 2455 7	[23910] 2700 6	[26090] 2950 5	[28270] 3195 4	[30460] 3440 4
[8] 30	[2040] 230 31	[4220] 475 30	[6400] 725 29	[8590] 970 28	[10770] 1215 28	[12950] 1465 27	[15140] 1710 26	[17320] 1955 25	[19500] 2200 24	[21690] 2450 23	[23870] 2695 22			
[12] 45	[1990] 225 47	[4170] 470 46	[6350] 715 45	[8540] 965 44	[10720] 1210 43	[12900] 1460 43	[15090] 1705 42	[17270] 1950 41	[19450] 2200 40	[21640] 2445 39				
[16] 61	[1930] 220 63	[4110] 465 62	[6290] 710 61	[8480] 960 60	[10660] 1205 59	[12840] 1450 58	[15030] 1700 57	[17210] 1945 56	[19390] 2190 55					
[20] 76	[1860] 210 79	[4040] 455 78	[6220] 705 77	[8410] 950 76	[10590] 1195 75	[12770] 1445 74	[14960] 1690 73	[17140] 1935 72	[19320] 2185 72					
[24] 91	[1780] 200 95	[3970] 450 94	[6150] 695 93	[8330] 940 92	[10520] 1190 91	[12700] 1435 90	[14880] 1680 89	[17070] 1930 88						
[28] 106	[1700] 190 111	[3890] 440 110	[6070] 685 109	[8250] 930 108	[10440] 1180 107	[12620] 1425 106	[14800] 1675 105	[16990] 1920 104						
[32] 121	[1620] 185 127	[3800] 430 126	[5980] 675 125	[8160] 920 124	[10350] 1170 123	[12530] 1415 122	[14720] 1665 121							
[36] 136	[1520] 170 143	[3710] 420 142	[5890] 665 141	[8070] 910 140	[10260] 1160 139	[12440] 1405 138	[14620] 1650 137							
[40] 151	[1420] 160 159	[3610] 410 158	[5790] 655 157	[7970] 900 156	[10160] 1150 155	[12340] 1395 154	[14520] 1640 153							
[45] 170	[1290] 145 179	[3480] 395 178	[5660] 640 177	[7840] 885 176	[10020] 1130 174	[12210] 1380 173	[14400] 1625 173							
[60] 227	[860] 95 239	[3040] 345 238	[5230] 590 236	[7410] 835 235	[9600] 1085 234	[11780] 1330 233								
[70] 265	[540] 60 279	[2720] 305 278	[4910] 555 276	[7090] 800 275	[9270] 1045 274	[11460] 1295 273								

# 10,000 Series

## Dimensions

### Ports

- 1 5/16 -12 UN-2B SAE O-ring Staggered Ports (2)
- 9/16 -18 UNF-2B SAE O-ring Case Drain Port (1) or
- 4 Bolt 1 1/4 inch Split Flange Ports (2)
- 9/16 -18 UNF-2B SAE O-ring Case Drain Port (1)

### Standard Rotation Viewed from Shaft End

- Port A Pressurized — CW
- Port B Pressurized — CCW

## Standard Mount

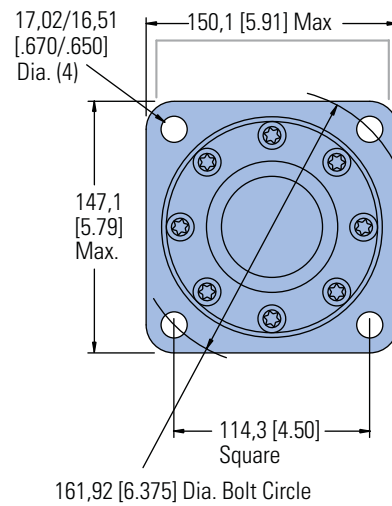
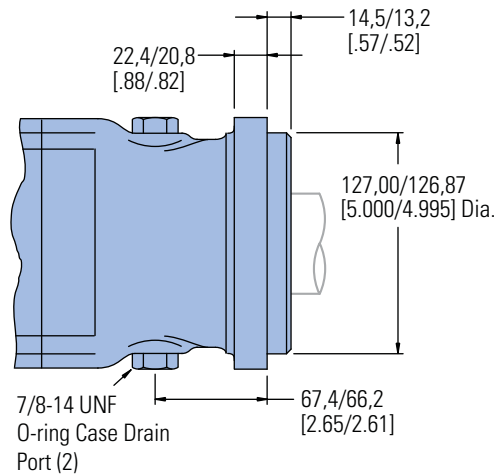
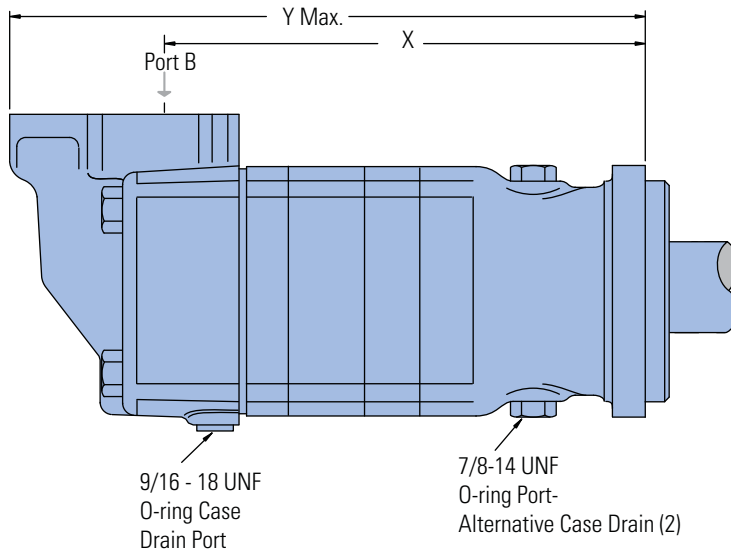

### STANDARD MOUNT MOTOR DIMENSIONS

Displacement cm <sup>3</sup> /r [in <sup>3</sup> /r]	X mm [inch]	Y mm [inch]
345 [21.0]	282,4 [11.12]	380,7 [14.99]
480 [29.2]	295,1 [11.62]	393,4 [15.49]
665 [40.6]	295,1 [11.62]	393,4 [15.49]
940 [57.4]	313,4 [12.34]	411,7 [16.21]

C-6

# 10,000 Series

## Dimensions

### Ports

- 1 5/16 -12 UN-2B SAE O-ring Staggered Ports (2)
- 9/16 -18 UNF-2B SAE O-ring Case Drain Port (1) or
- 4 Bolt 1 1/4 inch Split Flange Ports (2)
- 9/16 -18 UNF-2B SAE O-ring Case Drain Port (1)

### Standard Rotation Viewed from Shaft End

- Port A Pressurized — CW
- Port B Pressurized — CCW

## Wheel Mount

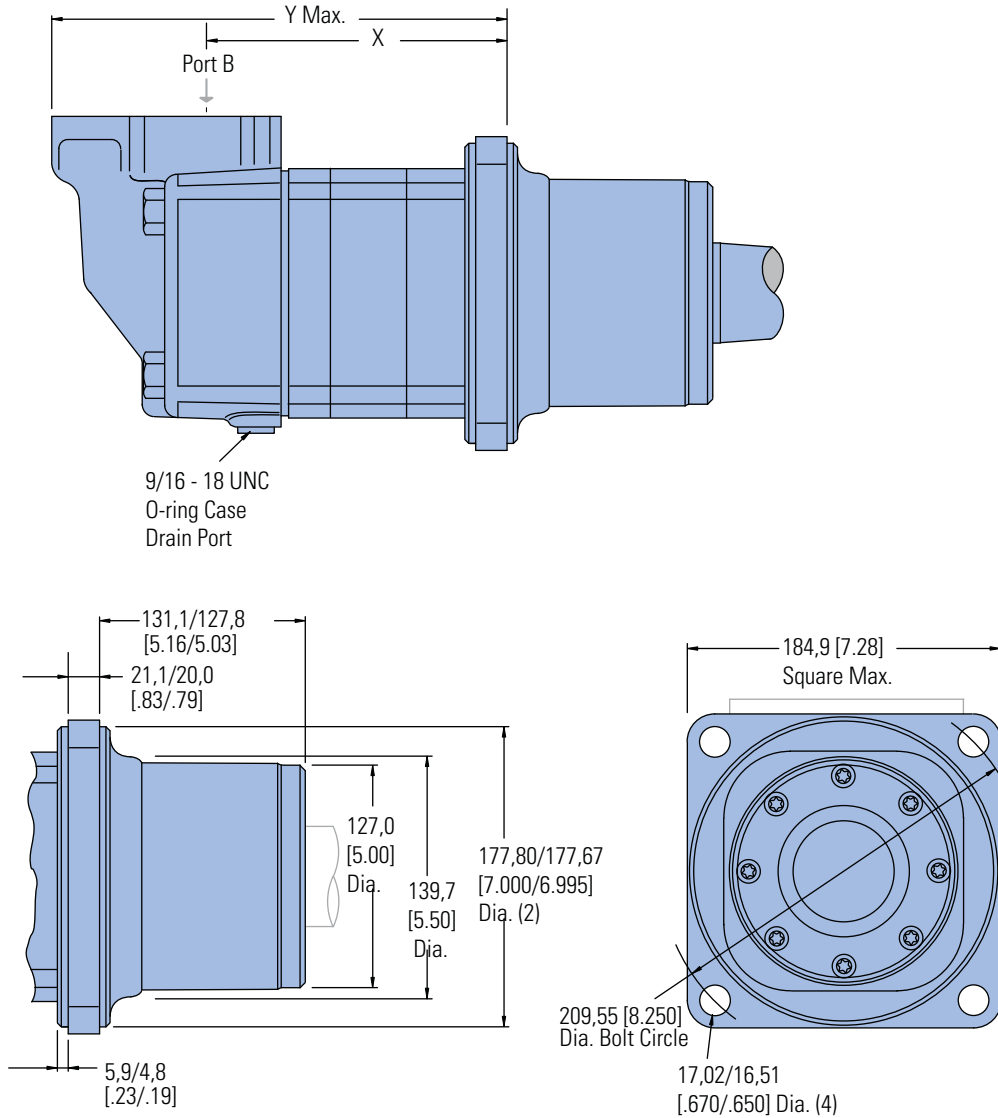

### WHEEL MOUNT MOTOR DIMENSIONS

Displacement cm <sup>3</sup> /r [in <sup>3</sup> /r]	X mm [inch]	Y mm [inch]
345 [21.0]	166,9 [6.57]	265,9 [10.47]
480 [29.2]	179,6 [7.07]	278,6 [10.97]
665 [40.6]	179,6 [7.07]	278,6 [10.97]
940 [57.4]	197,8 [7.79]	297,2 [11.70]

# 10,000 Series

Dimensions

Bearingless

## Ports

- 1 5/16 -12 UN-2B SAE O-ring Staggered Ports (2)
- 9/16 -18 UNF-2B SAE O-ring Case Drain Port (1) or
- 4 Bolt 1 1/4 inch Split Flange Ports (2)
- 9/16 -18 UNF-2B SAE O-ring Case Drain Port (1)

## Standard Rotation Viewed from Shaft End

- Port A Pressurized — CW
- Port B Pressurized — CCW

## Bearingless

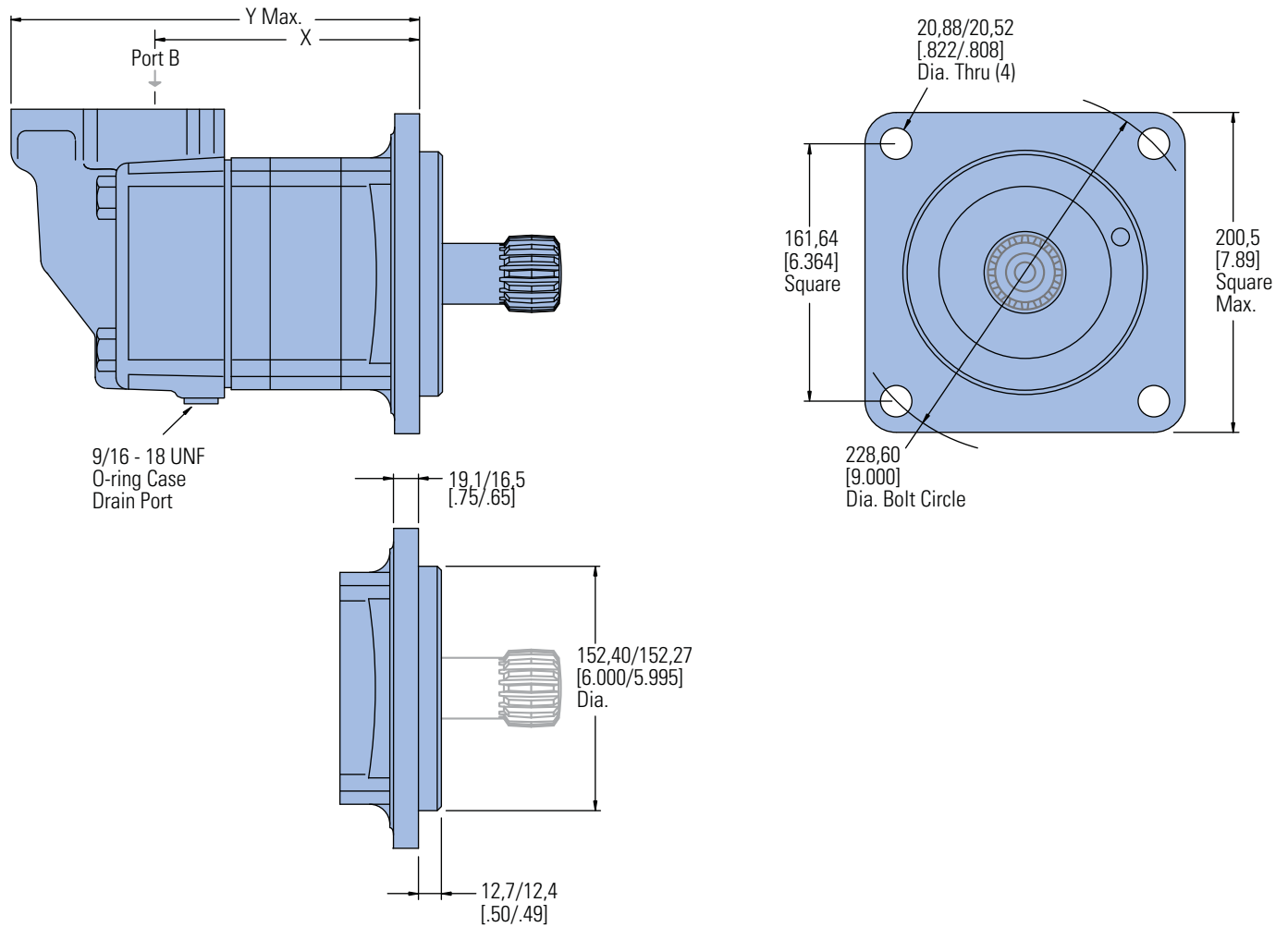

### BEARINGLESS MOTOR DIMENSIONS

Displacement cm <sup>3</sup> /r [in <sup>3</sup> /r]	X mm [inch]	Y mm [inch]
345 [21.0]	158,0 [6.22]	256,3 [10.09]
480 [29.2]	170,7 [6.72]	269,0 [10.59]
665 [40.6]	170,7 [6.72]	269,0 [10.59]
940 [57.4]	189,0 [7.44]	287,5 [11.32]

### Mating Coupling Blank

Dimension D mm [inch]  
Eaton Part No.

13280-001	133,6/128,5 [5.26/5.06]
13280-002	156,0/150,9 [6.14/5.94]

For 10,000 bearingless motor application information, contact your Eaton representative (mating coupling blanks available from Eaton Hydraulics).

### Note:

After machining blank, part must be hardened per Eaton specification.

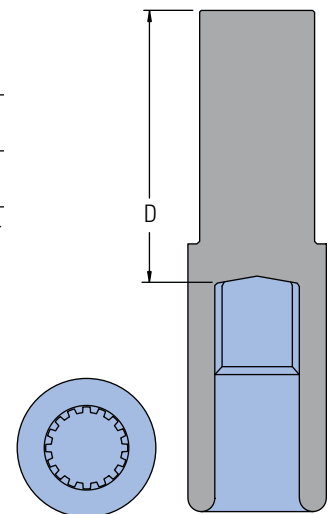

C-6

# 10,000 Series

## Installation Information

### Bearingless

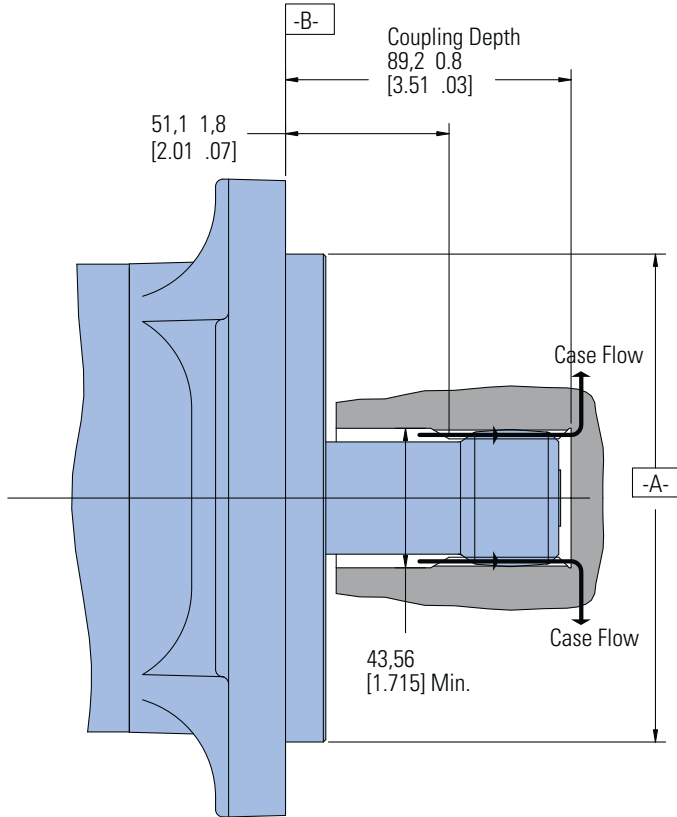

1 Internal spline in mating part to be as follows: Material to be ASTM A304, 8620H. Carbonize to a hardness of 60-64 HRC with case depth (to 50HRC) of 0,076 - 1,02 [.030 - .040] (dimensions apply after heat treat).

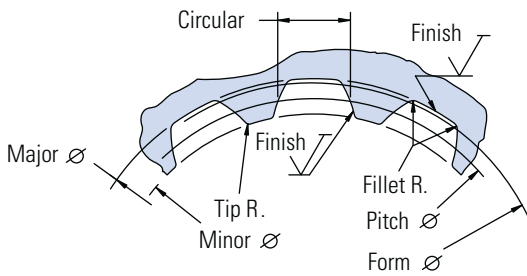

Spline Pitch.....	10/20
Pressure Angle.....	.30°
Number of teeth.....	16
Class of Fit.....	Ref. 5
Type of Fit.....	Side
Pitch Diameter .....	Ref. 40,640000 [1.600000] $\text{Ⓢ} 0,25 [0.010]   D$
Base Diameter.....	Ref. 35,195272 [1.3856406]
Major Diameter.....	43,56 [1.715] Max. 43,18 [1.700] Min.
Min. Minor Diameter.....	36,83 - 37,08 [1.450 - 1.460]
Form Diameter, Min.....	42,47 [1.672]
Fillet Radius.....	0,64 - 0,76 [0.025 - .030]
Tip Radius.....	0,25 - 0,51 [0.010 - .020]
Finish.....	1,6 (63)
Involute Profile Variation.....	+0,000 -0,028 [+0.0000 -0.0011]
Total Index Variation .....	0,041 [0.0016]
Lead Variation .....	0,013 [0.0005]
Circular Space Width:	
Maximum Actual.....	4,105 [0.1616]
Minimum Effective .....	3,995 [0.1573]
Maximum Effective .....	Ref. 4,056 [0.1597]
Minimum Actual .....	Ref. 4,018 [0.1582]
Dimension Between Two Pins.....	Ref. 26,929 - 27,084 [1.0602 - 1.0663]
Pin Diameter .....	Ref. 34,272 - 34,450 [1.3493 - 1.3563]
	Wide Flat for Root Clearance



# 10,000 Series

## Dimensions

### Shafts

#### 2 1/4 Inch Straight

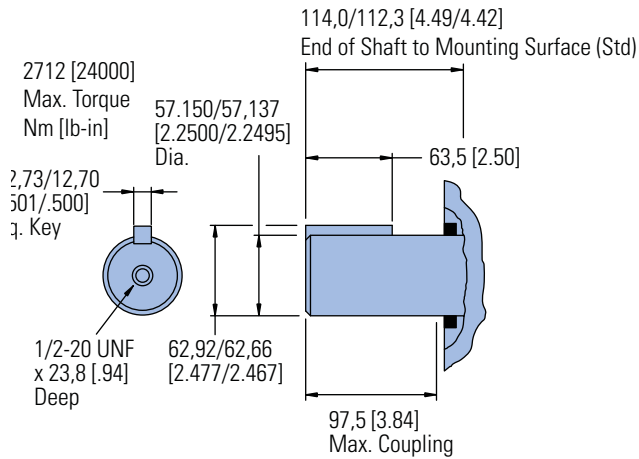

#### 2 1/4 Inch Tapered

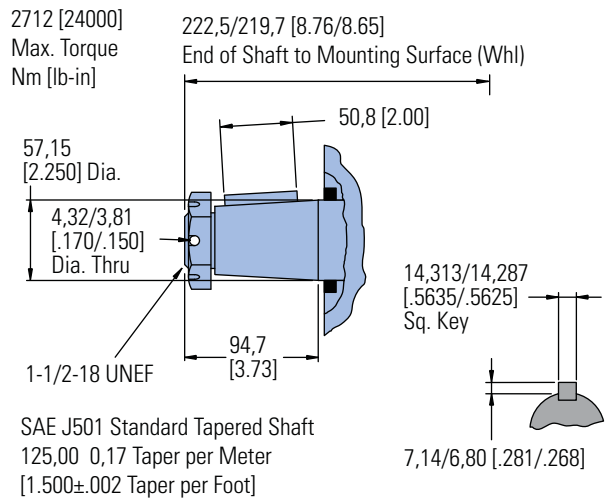

#### 2 1/8 Inch 16 Tooth Splined

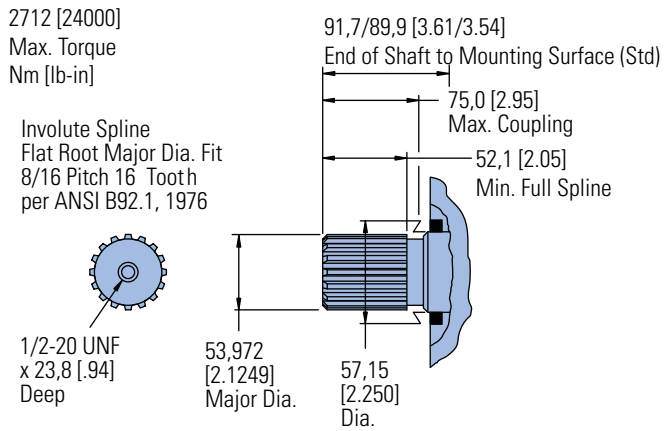

#### Tapered Shaft Hub Data

Recommended Torque:  
(1150 Nm [850 lb-ft] Dry)  
( 880 Nm [650 lb-ft] Lub)  
Plus Torque required to  
align the slotted nut with  
the Shaft Crosshole.

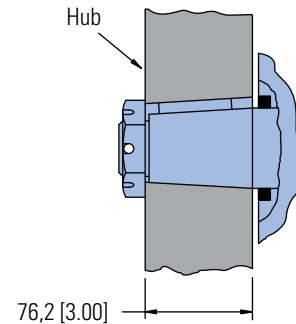

#### Slotted Hexagon Nut

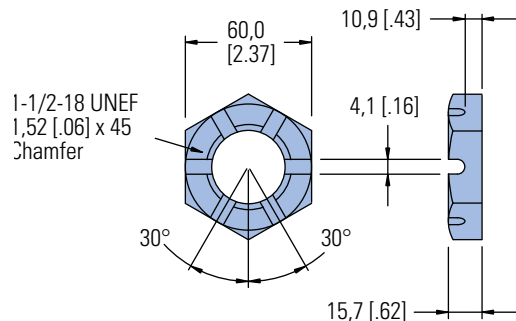

# 10,000 Series

## Side Shaft Load Capacity

These curves indicate the radial load capacity on the motor shaft at various locations with an external thrust load of 454 kg [1000 lb]. The maximum allowable thrust load is 908 kg [2000 lb].

**Note:**

Case pressure will increase the allowable inward thrust load and decrease the allowable outward thrust load. Case pressure will push outward on the shaft at 200 kg/7 Bar [441 lb/100 PSI].

**Each curve is based on**

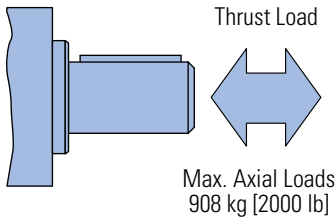

**B 10 bearing life (2000 hours of 12,000,000 shaft revolutions at 100 RPM) at rated output torque.**

To determine radial load at speeds other than 100 RPM, multiply the load values given on the bearing curve by the factors in the chart below.

RPM	Multiplication Factor
50	1.23
100	1.00
200	0.81
300	0.72
400	0.66
500	0.62
600	0.58
700	0.56
800	0.54

For 3,000,000 shaft revolutions or 500 hours—Increase these shaft loads 52%.

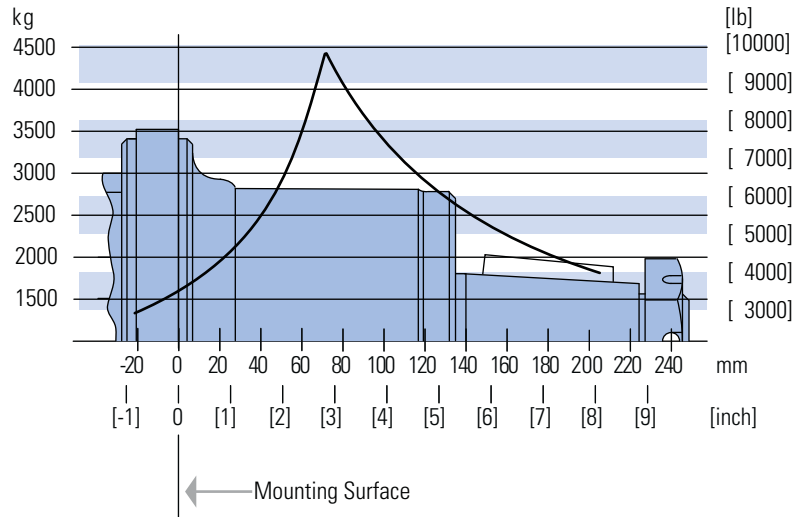
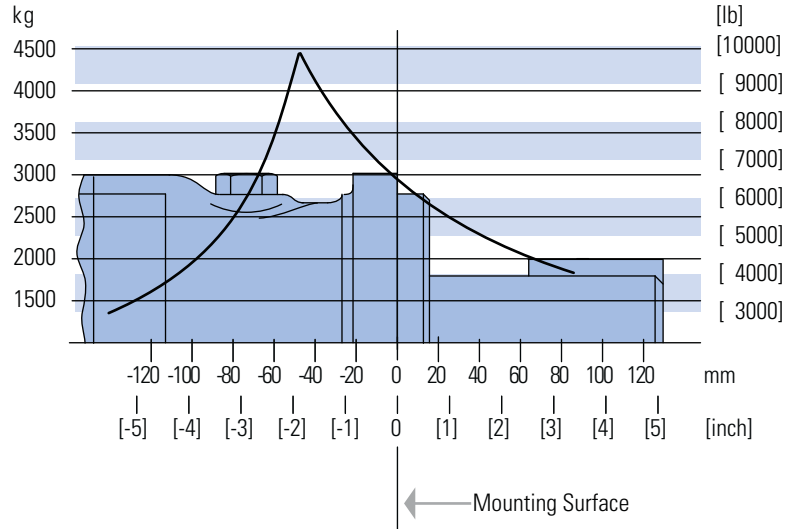

# 10,000 Series

## Dimensions

### Ports

#### 1 1/4 Inch Split Flange Ports (2)

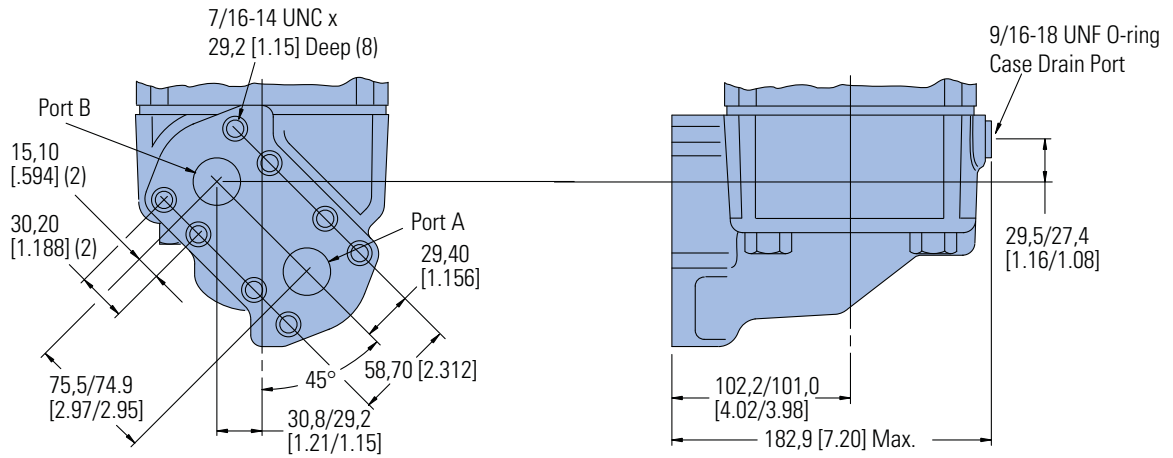

#### 1 5/16 -12 O-ring Ports (2)

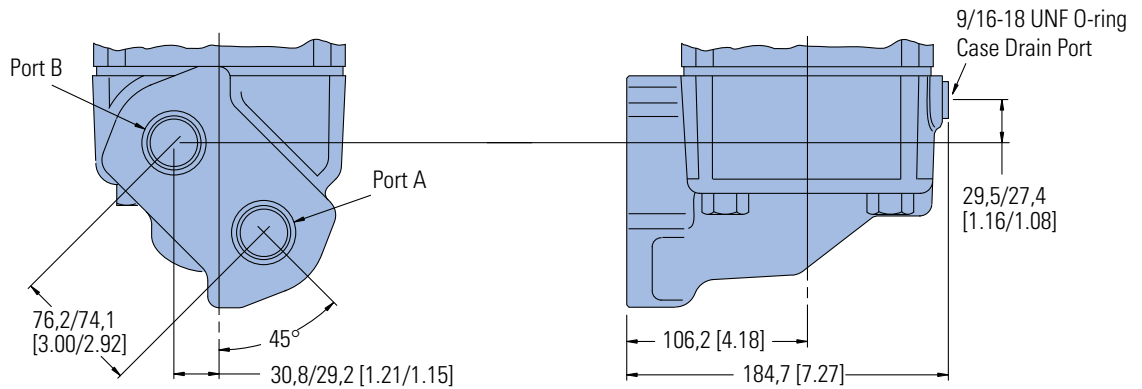

#### End View Common Dimensions

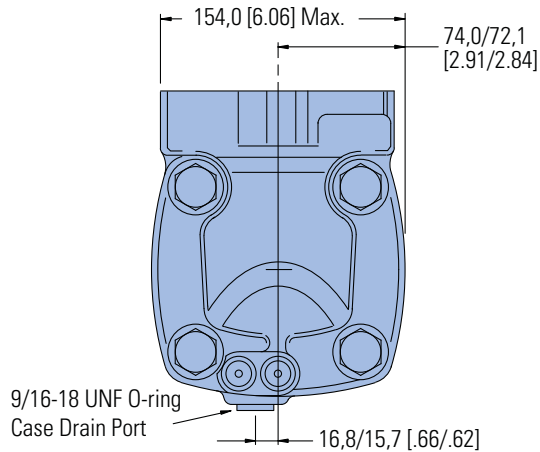

C-6

# 10,000 Series

## Product Numbers

### Note:

For 10,000 Series Motors with a configuration **Not Shown** in the chart below: Use model code number system on the next page to specify product in detail.

Use digit prefix — 119-, 120-, or 121 - plus four digit number from charts for complete product number— Example 121-1014.

**Orders will not be accepted without three digit prefix.**

MOUNTING	SHAFT	PORT SIZE	DISPL. cm <sup>3</sup> /r [in <sup>3</sup> /r] / PRODUCT NUMBER			
			345 [21.0]	480 [29.3]	665 [40.6]	940 [57.4]
Standard SAE C-Mount	2 1/4 Inch Straight	1 5/16 O-ring	119-1028	-1029	-1030	-1031
		1 1/4 inch Split Flange	119-1040	-1041	-1042	-1043
	2 1/8 Inch 16 T Splined	1 5/16 O-ring	119-1032	-1033	-1034	-1035
		1 1/4 inch Split Flange	119-1044	-1045	-1046	-1047
	2 1/4 Inch Tapered	1 5/16 O-ring	119-1036	-1037	-1038	-1039
		1 1/4 inch Split Flange	119-1048	-1049	-1050	-1051
Wheel Motor	2 1/4 Inch Straight	1 5/16 O-ring	120-1005	-1006	-1007	-1008
		1 1/4 inch Split Flange	120-1017	-1018	-1019	-1020
	2 1/8 Inch 16 T Splined	1 5/16 O-ring	120-1009	-1010	-1011	-1012
		1 1/4 inch Split Flange	120-1021	-1022	-1023	-1024
	2 1/4 Inch Tapered	1 5/16 O-ring	120-1013	-1014	-1015	-1016
		1 1/4 inch Split Flange	120-1025	-1026	-1027	-1028
Bearingless		1 5/16 O-ring	121-1007	-1008	-1009	-1010
		1 1/4 inch Split Flange	121-1011	-1012	-1013	-1014

121-1014

# 10,000 Series

## Model Code

The following 30-digit coding system has been developed to identify all of the configuration options for the 10,000 Series motor. Use this model code to specify a motor with the desired features. All 30-digits of the code must be present when ordering. You may want to photocopy the matrix below to ensure that each number is entered in the correct box.

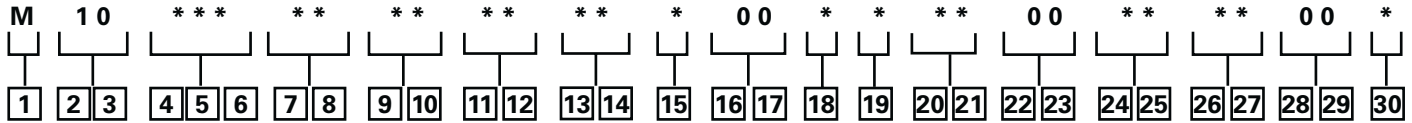

### 1 Product M – Motor

### 2, 3 Series 10 – 10,000 Series

### 4, 5, 6 Displacement cm<sup>3</sup>/r [in<sup>3</sup>/r]

210 – 343.8 [20.98]  
293 – 479.5 [29.26]  
406 – 665.3 [40.60]  
574 – 940.8 [57.41]

### 7, 8 Mounting Description

**AA** – Standard, 4 Bolt:  
127,0 [5.00] Pilot Dia. 16,76  
[.660] Dia. Holes on 161,92  
[6.375] Dia. Bolt Circle  
**AB** – Wheel, 4 Bolt: 16,76  
[.660] Dia. Holes on 209,55  
[8.250] Dia. Bolt Circle  
**AC** – Bearingless, 4 Bolt:  
152,4 [6.00] Pilot Dia. 20,70  
[.815] Holes on 228,60 [9.00]  
Dia. Bolt Circle

### 9, 10 Output Shaft Description

00 – None (Bearingless)  
**01** – 57,15 [2.250] Dia.  
Straight with .500-20  
UNF-2B Thread in End,  
12,7 [.50] Square x 63,5  
[2.50] Straight End  
**02** – 57,15 [2.250] Dia.  
.125:1 Tapered Shaft Per  
SAE J512 with 1.500-18  
UNEF-2A Threaded Shaft  
End and Slotted Hex Nut,  
14,288 [.5625] Square x  
50,8 [2.00] Straight Key  
**03** – 53,98 [2.125] Dia. Flat  
Root, Major Dia. Fit, 16  
Tooth, 8/16 DP, 30 Degree  
Involute Spline with  
.500-20 UNF-20 Thread  
in End. 52,07 [2.050]  
Minimum Full Spline  
Length

### 11, 12 Ports

**AA** – 1.3125-.12 UN O-Ring  
Staggered Ports  
**AB** – 31,75 [1.250] Dia.  
4 Bolt Split Flange  
Staggered Ports with  
.4375-15 UNC-2B Tapped  
Mounting Holes

### 13, 14 Case Flow Options 01 – .5625-18 UNF-2B Case Drain SAE O-Ring Port

### 15 Low Pressure Relief 0 – None

### 16, 17 Pressure/Flow Option 00 – None

### 18 Geroler Option 0 – Standard 1 - Free Running

### 19 Seal Option 0 – Standard 4 – Seal Guard

### 20, 21 Accessories 00 – None

### 22, 23 Special Features (Hardware) 00 – None

### 24, 25 Special Features (Assembly) 00 – None

AA – Reverse Rotation

### 26, 27 Paint / Packaging 00 – None AA – Low Gloss Black Primer

### 28, 29 Customer Identification 00 – None

### 30 Design Code C – Third (Standard and Wheel Mounts) D – Fourth (Bearingless Mount)

Feature in **bold** are preferred and allow for shorter lead time.