

Hydrostatic Pump Repair

www.hydrostaticpumprepair.net

Phone: 800-361-0028

Email: sales@hydrostatic-transmission.com

6000 Series

Highlights

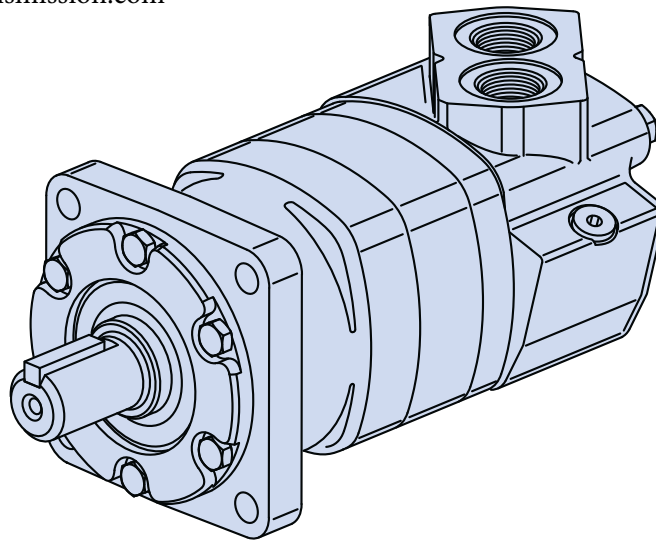

Features

- 9 displacements available
- Presents a multitude of options that make this motor very “smart” and flexible to apply

Benefits

- Very tough motor for demanding applications
- Can be used in a multitude of industries
- Very easy/flexible to integrate in a system

Applications

- Mobile equipment
- Snow Removal, mowing
- Sprayer, trencher
- Wood products

Description

With torque up to 15,000 in-lb and 40 gpm continuous, this motor is packed with power operates very smoothly.

Specifications

Geroler Element	9 Displacements
Flow l/min [GPM]	150 [40] Continuous** 225 [60] Intermittent*
Speed RPM	775 Cont.** 866 Inter.*
Pressure bar [PSI]	200 [3000] Cont.** 300 [4500] Inter.*
Torque Nm [lb-in]	1685 [14920] Cont.** 1875 [16580] Inter.*

** Continuous — (Cont.) Continuous rating, motor may be run continuously at these ratings.

* Intermittent — (Inter.) Intermittent operation, 10% of every minute.

C-5



Mowing



Snow Removal



Sprayer



Trencher

6000 Series

Specifications

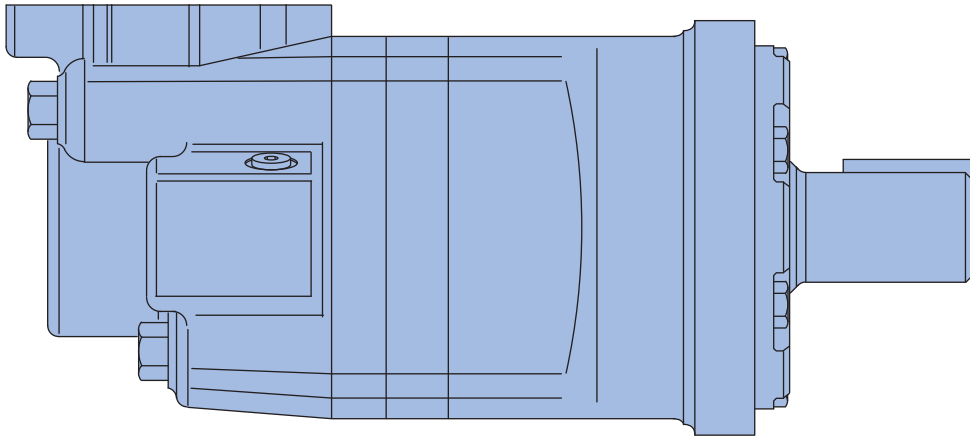

6000 SERIES MOTORS

Displ. cm ³ /r [in ³ /r]		195 [11.9]	245 [15.0]	310 [19.0]	390 [23.9]	490 [30.0]	625 [38.0]	735 [45.0]	805 [49.0]	985 [60.0]
Max. Speed (RPM)	Continuous	775	615	485	387	307	241	203	187	153
	Intermittent	866	834	698	570	454	355	303	280	230
@ Flow										
Flow l/min [GPM]	Continuous	150 [40]	150 [40]	150 [40]	150 [40]	150 [40]	150 [40]	150 [40]	150 [40]	150 [40]
	Intermittent	170 [45]	210 [55]	225 [60]	225 [60]	225 [60]	225 [60]	225 [60]	225 [60]	225 [60]
Torque* Nm [lb-in]	Continuous	575 [5100]	735 [6510]	930 [8230]	1155 [10230]	1445 [12800]	1480 [13100]	1378 [12192]	1582 [14004]	1685 [14920]
	Intermittent	860 [7620]	1100 [9740]	1355 [11990]	1635 [14490]	1885 [16670]	1898 [16800]	1699 [15040]	1850 [16377]	1875 [16580]
Pressure Δ bar [Δ PSI]	Continuous	205 [3000]	205 [3000]	205 [3000]	205 [3000]	205 [3000]	170 [2500]	140 [2000]	140 [2000]	140 [2000]
	Intermittent	310 [4500]	310 [4500]	310 [4500]	310 [4500]	275 [4000]	221 [3200]	170 [2500]	170 [2500]	140 [2000]
	Peak	310 [4500]	310 [4500]	310 [4500]	310 [4500]	310 [4500]	240 [3500]	205 [3000]	170 [2500]	170 [2250]
Weight kg [lb]	Standard or Wheel Mount	24,9 [55.0]	25,2 [55.5]	25,6 [56.5]	26,3 [58.0]	27,0 [59.5]	27,9 [61.5]	28,6 [63.0]	29 [64.0]	30,4 [67.0]
	Bearingless	20,2 [44.5]	20,4 [45.0]	20,9 [46.0]	21,5 [47.5]	22,2 [49.0]	23,1 [51.0]	28,3 [52.5]	28,8 [53.5]	30,2 [56.5]

Maximum Case Pressure: See case pressure seal limitation graph.

*See shaft torque ratings for limitations..

Note:

To assure best motor life, run motor for approximately one hour at 30% of rated pressure before application to full load. Be sure motor is filled with fluid prior to any load applications.

Maximum Inlet Pressure:

310 bar [4500 PSI]
Do not exceed Δ pressure rating (see chart above).

Maximum Return Pressure:

310 bar [4500 PSI] with case drain line installed.
Do not exceed Δ pressure rating (see chart above).

Δ bar [Δ PSI] :

The true pressure difference between inlet port and outlet port

Continuous Rating:

Motor may be run continuously at these ratings

Intermittent Operation:

10% of every minute

Peak Operation:

1% of every minute

Recommended Fluids:

Premium quality, anti-wear type hydraulic oil with a viscosity of not less than 70 SUS at operating temperature.

Recommended System Operating Temp.:

-34°C to 82°C [-30°F to 180°F]

Recommended Filtration:

per ISO Cleanliness Code, 4406: 20/18/13

6000 Series

Performance Data

Motors run with high efficiency in all areas designated with a number for torque and speed. For best motor life select a motor to run with a torque and speed range shown in the light shaded area.

Performance data is typical at 120 SUS. Actual data may vary slightly from unit to unit in production.

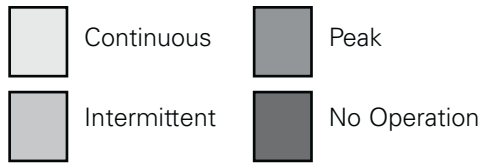

195 cm³/r [11.9 in³/r]
 Δ Pressure Bar [PSI]

	[250] 15	[500] 35	[1000] 70	[1500] 105	[2000] 140	[2500] 170	[3000] 205	[3500] 240	[4000] 275	[4500] 310
[.5] 1,9	[280] 30 9	[650] 75 7	[1450] 165 5	[2290] 260 2						
[2] 7,5	[290] 35 38	[680] 75 37	[1500] 170 35	[2340] 265 34	[3100] 350 30	[3880] 440 26	[4140] 470 18			
[4] 15	[300] 35 77	[710] 80 76	[1500] 175 74	[2390] 270 72	[3200] 365 66	[4030] 455 62	[4600] 520 46	[5200] 590 32	[5790] 655 18	
[8] 30	[310] 35 154	[740] 85 153	[1590] 180 148	[2450] 275 144	[3280] 370 131	[4120] 465 119	[4810] 545 116	[5530] 625 99	[6250] 705 83	[6900] 780 65
[12] 45	[320] 35 232	[750] 85 230	[1610] 180 225	[2480] 280 221	[3330] 375 212	[4190] 475 203	[4990] 565 186	[5810] 655 167	[6630] 750 148	[7320] 825 118
[16] 61	[300] 35 309	[730] 80 307	[1600] 180 303	[2470] 280 300	[3340] 375 291	[4210] 475 283	[5090] 575 258	[5900] 665 236	[6710] 760 214	[7470] 845 181
[20] 76	[270] 30 387	[720] 80 384	[1590] 180 379	[2460] 280 374	[3350] 380 365	[4240] 480 356	[5100] 575 332	[5950] 670 306	[6800] 770 280	[7620] 860 247
[24] 91	[240] 25 465	[700] 80 462	[1570] 175 456	[2440] 275 450	[3330] 375 440	[4220] 475 429	[5080] 575 413	[5940] 670 388	[6810] 770 363	
[28] 106	[190] 20 542	[660] 75 539	[1530] 175 532	[2400] 270 526	[3300] 375 514	[4200] 475 502	[5060] 570 476	[5940] 670 448	[6810] 770 421	
[32] 121	[160] 20 620	[630] 70 617	[1500] 170 609	[2370] 270 602	[3270] 370 589	[4160] 470 576	[5040] 570 542	[5920] 670 511	[6790] 765 480	
[36] 136	[120] 15 697	[620] 70 692	[1480] 165 683	[2350] 265 674	[3240] 365 659	[4130] 465 645	[5000] 565 601	[5880] 665 564	[6760] 765 527	
[40] 151	[80] 10 775	[610] 70 770	[1450] 165 759	[2320] 260 749	[3210] 365 733	[4100] 465 718	[4960] 560 666	[5840] 660 624		
[45] 170		[590] 65 866	[1410] 160 854	[2280] 260 843	[3170] 360 825	[4060] 460 808	[4920] 555 749	[5790] 655 702		

245 cm³/r [15.0 in³/r]
 Δ Pressure Bar [PSI]

	[250] 15	[500] 35	[1000] 70	[1000] 105	[2000] 140	[2500] 170	[3000] 205	[3500] 240	[4000] 275	[4500] 310
[.5] 1,9	[430] 50 7	[860] 95 4	[1890] 215 1							
[2] 7,5	[440] 50 30	[900] 100 29	[1940] 220 26	[2990] 340 24	[3960] 445 21	[4920] 555 17	[5040] 570 11	[5930] 670 6		
[4] 15	[460] 50 61	[940] 105 60	[2000] 225 56	[3060] 345 54	[4080] 460 48	[5090] 575 42	[5680] 640 39	[6630] 750 30	[7570] 855 12	[8520] 965 6
[8] 30	[470] 55 122	[960] 110 120	[2060] 235 116	[3150] 355 113	[4210] 475 104	[5260] 595 95	[6180] 700 81	[7100] 800 67	[8020] 905 53	[9020] 1020 37
[12] 45	[480] 55 183	[970] 110 182	[2080] 235 178	[3180] 360 174	[4270] 480 165	[5360] 605 157	[6390] 720 141	[7420] 840 125	[8450] 955 109	[9510] 1075 92
[16] 61	[450] 50 245	[960] 110 244	[2070] 235 240	[3180] 360 236	[4290] 485 228	[5420] 610 221	[6480] 730 202	[7490] 845 184	[8480] 960 165	[9540] 1180 145
[20] 76	[420] 45 307	[940] 105 306	[2050] 230 301	[3160] 355 358	[4290] 485 287	[5440] 615 277	[6510] 735 257	[7580] 855 238	[8660] 980 218	[9740] 1100 197
[24] 91	[380] 45 368	[920] 105 365	[2020] 230 361	[3120] 355 358	[4260] 480 348	[5400] 610 338	[6490] 735 316	[7590] 860 294	[8680] 980 271	
[28] 106	[330] 35 430	[870] 100 426	[1980] 225 421	[3100] 350 416	[4240] 480 404	[5380] 610 376	[6480] 730 358	[7580] 855 340	[8670] 980 322	
[32] 121	[290] 35 491	[800] 90 489	[1920] 215 481	[3050] 345 475	[4170] 470 461	[5290] 600 448	[6410] 725 423	[7520] 850 398	[8640] 975 373	
[36] 136	[250] 30 556	[730] 80 549	[1850] 210 543	[2980] 335 537	[4060] 460 524	[5150] 580 509	[6300] 710 482	[7440] 840 456		
[40] 151	[200] 25 615	[690] 80 612	[1790] 200 606	[2940] 330 599	[4010] 455 585	[5130] 580 570	[6190] 700 540	[7100] 800 510		
[45] 170		[570] 65 688	[1760] 200 682	[2860] 325 674	[3960] 445 658	[5070] 575 641	[6080] 685 608	[6990] 755 574		
[50] 189			[1720] 195 758	[2800] 315 749	[3890] 440 731	[4920] 555 712	[5940] 670 676			
[55] 208			[1670] 190 834	[2740] 310 824	[3820] 430 804	[4890] 550 783	[5880] 665 744			

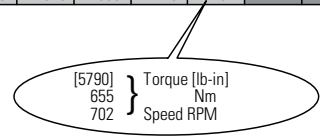

6000 Series

Performance Data

Motors run with high efficiency in all areas designated with a number for torque and speed. For best motor life select a motor to run with a torque and speed range shown in the light shaded area.

Performance data is typical at 120 SUS. Actual data may vary slightly from unit to unit in production.

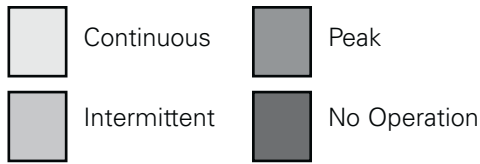

310 cm³/r [19.0 in³/r]
 Δ Pressure Bar [PSI]

[250] 15	[500] 35	[1000] 70	[1500] 105	[2000] 140	[2500] 170	[3000] 205	[3500] 240	[4000] 275	[4500] 310
-------------	-------------	--------------	---------------	---------------	---------------	---------------	---------------	---------------	---------------

[5] 1,9	[530] 60 6	[1120] 125 4	[2440] 275 1						
[2] 7,5	[540] 60 24	[1150] 130 23	[2460] 280 22	[3620] 410 20	[4780] 540 17	[5690] 645 14	[6670] 755 10	[7780] 880 4	
[4] 15	[550] 60 48	[1180] 135 47	[2560] 290 45	[3800] 430 42	[5030] 570 38	[6050] 685 32	[7070] 800 24	[8260] 935 17	[9070] 1025 10
[8] 30	[560] 65 96	[1250] 140 95	[2650] 300 91	[3970] 450 87	[5280] 595 81	[6480] 730 73	[7710] 870 64	[8740] 985 55	[9770] 1105 46
[12] 45	[570] 65 144	[1260] 140 143	[2690] 305 140	[4050] 460 135	[5420] 610 129	[6730] 760 121	[8040] 910 111	[9260] 1045 99	[10490] 1185 88
[16] 61	[540] 60 193	[1230] 140 192	[2660] 300 188	[4060] 460 184	[5450] 615 178	[6800] 770 167	[8150] 920 156	[9400] 1060 141	[10660] 1205 126
[20] 76	[510] 60 242	[1200] 135 241	[2630] 295 232	[4040] 455 232	[5450] 615 226	[6820] 770 216	[8190] 925 201	[9520] 1075 184	[10840] 1225 167
[24] 91	[480] 55 290	[1160] 130 289	[260] 295 282	[4020] 455 279	[5440] 615 273	[6840] 775 260	[8230] 930 248	[9560] 1080 232	[10900] 1230 215
[28] 106	[420] 45 339	[1130] 130 336	[2570] 290 333	[3990] 450 328	[5420] 610 320	[6820] 770 308	[8220] 930 295	[9520] 1075 276	[10840] 1225 257
[32] 121	[360] 40 388	[1100] 125 384	[2510] 285 381	[3920] 445 375	[5330] 600 368	[6750] 765 354	[8170] 920 341	[9440] 1065 320	
[36] 136	[300] 35 436	[1060] 120 430	[2440] 275 421	[3830] 435 416	[5220] 590 410	[6660] 750 396	[8100] 915 383	[9330] 1055 360	
[40] 151	[270] 30 485	[1020] 115 478	[2400] 270 466	[3780] 425 461	[5150] 580 456	[6580] 745 441	[8020] 905 427	[9220] 1040 403	
[50] 189		[982] 110 597	[2180] 245 582	[3420] 385 576	[4660] 525 570	[6050] 685 551	[7440] 840 534		
[60] 227			[1960] 220 698	[3250] 365 691	[4540] 515 684	[5750] 650 661	[7080] 800 641		

390 cm³/r [23.9 in³/r]
 Δ Pressure Bar [PSI]

[250] 15	[500] 35	[1000] 70	[1500] 105	[2000] 140	[2500] 170	[3000] 205	[3500] 240	[4000] 275	[4500] 310
-------------	-------------	--------------	---------------	---------------	---------------	---------------	---------------	---------------	---------------

[1] 3,8	[760] 85 4	[1570] 175 2	[3230] 365 1						
[2] 7,5	[780] 90 19	[1610] 180 18	[3270] 370 17	[4910] 555 16	[6440] 730 14	[7760] 875 12	[9080] 1025 9	[10590] 1195 4	
[4] 15	[800] 90 38	[1640] 185 38	[3300] 375 37	[4970] 560 35	[6570] 740 33	[8160] 920 29	[9570] 1080 22	[11270] 1275 14	[12120] 1370 5
[8] 30	[810] 90 77	[1650] 185 76	[3370] 380 74	[5080] 575 72	[6740] 760 68	[8430] 950 65	[10050] 1135 55	[11620] 1315 45	[12880] 1455 33
[12] 45	[800] 90 115	[1620] 185 115	[3390] 385 112	[5130] 580 109	[6810] 770 105	[8520] 965 100	[10190] 1150 91	[11860] 1340 81	[13640] 1540 79
[16] 61	[750] 85 154	[1600] 180 154	[3380] 380 151	[5120] 580 147	[6820] 770 143	[8560] 965 132	[10230] 1155 126	[11920] 1345 116	
[20] 76	[680] 75 193	[1580] 180 193	[3360] 380 189	[5120] 580 187	[6840] 775 182	[8590] 970 175	[10280] 1160 162	[11980] 1355 152	
[24] 91	[620] 70 232	[1520] 170 230	[3280] 370 229	[5060] 570 225	[6780] 765 220	[8530] 965 212	[10240] 1155 204		
[28] 106	[570] 65 270	[1460] 165 268	[3210] 365 266	[5000] 565 261	[6730] 760 256	[8480] 960 248	[10200] 1150 236		
[32] 121	[530] 60 309	[1420] 160 306	[3140] 355 304	[4930] 555 299	[6640] 750 292	[8380] 945 282	[10120] 1145 269		
[36] 136	[450] 50 348	[1370] 155 346	[3010] 340 340	[4840] 545 336	[6500] 730 329	[8250] 930 317	[10000] 1130 301		
[40] 151	[380] 45 387	[1320] 150 386	[2880] 325 380	[4740] 535 375	[6460] 730 368	[8120] 915 359			
[50] 189		[1140] 130 482	[2650] 300 475	[4540] 515 469	[6440] 730 460	[8050] 910 449			
[60] 227			[2460] 280 570	[4430] 500 562	[6360] 720 552	[7860] 890 538			

[5750]
 650
 661 } Torque [lb-in]
 } Nm
 } Speed RPM

6000 Series

Performance Data

Motors run with high efficiency in all areas designated with a number for torque and speed. For best motor life select a motor to run with a torque and speed range shown in the light shaded area.

Performance data is typical at 120 SUS. Actual data may vary slightly from unit to unit in production.

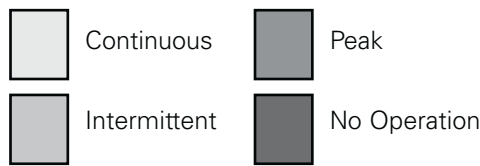

490 cm³/r [30.0 in³/r]
 Δ Pressure Bar [PSI]

	[250] 15	[500] 35	[1000] 70	[1500] 105	[2000] 140	[2500] 170	[3000] 205	[3500] 240	[4000] 275
[1] 3,8	[1010] 115 7	[1200] 235 7	[4260] 480 5	[6140] 695 3					
[2] 7,5	[1020] 115 15	[2110] 240 14	[4270] 480 13	[6280] 710 12	[8350] 945 11	[10420] 1175 8	[12140] 1370 3		
[4] 15	[1030] 115 30	[2100] 235 30	[4280] 485 29	[6410] 725 28	[8500] 960 27	[10590] 1195 25	[12500] 1410 21	[14580] 1645 17	[16670] 1885 12
[8] 30	[1020] 115 60	[2090] 235 60	[4290] 485 59	[6490] 735 57	[8620] 975 54	[10740] 1215 51	[12800] 1445 45	[14930] 1685 38	
[12] 45	[1000] 115 91	[2080] 235 91	[4290] 485 89	[6500] 735 87	[8650] 975 84	[10800] 1220 79	[12890] 1455 71		
[16] 61	[110] 960 122	[2060] 235 122	[4260] 480 121	[6480] 730 118	[8650] 975 114	[10820] 1220 109	[12900] 1460 100		
[20] 76	[900] 100 153	[1980] 225 152	[4180] 470 150	[6420] 725 147	[8620] 975 144	[10820] 1220 139			
[24] 91	[850] 95 184	[1930] 220 184	[4150] 470 181	[6390] 720 180	[8580] 970 176	[10770] 1215 171			
[28] 106	[740] 85 215	[1840] 210 214	[4070] 460 211	[6290] 710 208	[8500] 960 204	[10720] 1210 198			
[32] 121	[690] 80 245	[1710] 195 244	[3970] 450 241	[6190] 700 237	[8420] 950 232	[10660] 1205 226			
[36] 136	[670] 75 276	[1560] 175 275	[3860] 435 272	[6080] 685 265	[8340] 940 260	[10420] 1175 255			
[40] 151	[570] 65 307	[1400] 160 306	[3750] 425 303	[5970] 675 295	[8140] 920 290	[10180] 1150 284			
[50] 189		[1140] 130 382	[3240] 365 379	[5220] 590 369	[7620] 860 362				
[60] 227			[2860] 325 454	[4860] 550 442	[7140] 805 435				

625 cm³/r [38.0 in³/r]
 Δ Pressure Bar [PSI]

	[250] 15	[500] 35	[1000] 70	[1500] 105	[2000] 140	[2500] 170	[3000] 205	[3200] 221
[1] 3,8	[1060] 120 5	[2205] 250 5	[4515] 510 4	[6690] 755 2				
[2] 7,5	[1090] 125 12	[2300] 260 12	[4720] 535 13	[7025] 795 10	[9360] 1060 6			
[4] 15	[1145] 130 24	[2450] 275 24	[5052] 570 24	[7520] 850 21	[9410] 1065 16	[12700] 1434 13		
[8] 30	[1195] 135 45	[2600] 295 45	[5350] 605 44	[8195] 925 42	[11220] 1270 37	[13100] 1480 35	[15800] 1785 32	[16800] 1898 30
[12] 45	[1200] 135 72	[2600] 295 72	[5390] 610 71	[8145] 920 68	[11770] 1330 64	[13000] 1469 60	[15700] 1774 56	
[16] 61	[1120] 125 94	[2530] 285 94	[5340] 605 92	[8105] 915 89	[11740] 1325 85	[13000] 1469 83		
[20] 76	[1050] 120 120	[2465] 280 119	[5285] 595 117	[8080] 915 115	[11725] 1325 110			
[24] 91	[950] 105 144	[2365] 265 143	[5180] 585 140	[7990] 905 138	[11705] 1320 132			
[28] 106	[855] 95 169	[2255] 255 168	[5080] 575 165	[7915] 895 162	[11640] 1315 156			
[32] 121	[730] 80 193	[2140] 240 192	[4960] 560 188	[7775] 880 185	[11505] 1300 179			
[36] 136	[555] 65 217	[1965] 220 216	[4780] 540 213	[7585] 855 210				
[40] 151	[380] 45 241	[1790] 200 240	[4600] 520 238	[7395] 835 236				
[50] 189			[4180] 470 296	[6985] 790 290				
[60] 227			[3800] 430 353	[6600] 745 345				

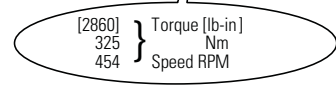





6000 Series

Performance Data

Motors run with high efficiency in all areas designated with a number for torque and speed. For best motor life select a motor to run with a torque and speed range shown in the light shaded area.

Performance data is typical at 120 SUS. Actual data may vary slightly from unit to unit in production.

	Continuous		Peak
	Intermittent		No Operation

735 cm ³/r [45.0 in ³/r] Δ Pressure Bar [PSI]

	[250] 15	[500] 35	[750] 50	[1000] 70	[1250] 85	[1500] 105	[1750] 120	[2000] 140	[2250] 155	[2500] 170
[1] 3,8	[1311] 148 4	[2775] 314 4	[4200] 475 3	[5480] 619 3	[7000] 791 2					
[2] 7,5	[1340] 151 10	[2856] 323 10	[4535] 512 10	[5809] 656 10	[7551] 853 9	[8685] 981 7	[10182] 1150 6	[11121] 1257 5		
[4] 15	[1253] 142 20	[2854] 322 20	[4363] 493 19	[5813] 657 18	[7272] 822 17	[8714] 985 16	[10135] 1145 14	[11537] 1303 13	[12970] 1465 11	[15040] 1699 11
[8] 30	[1290] 146 40	[2889] 326 39	[4540] 513 38	[6130] 693 38	[7703] 870 37	[9202] 1040 37	[10666] 1205 35	[12192] 1378 33	[13713] 1549 32	
[12] 45	[1277] 144 61	[2821] 319 60	[4528] 512 59	[6180] 698 58	[7795] 881 57	[9338] 1055 56	[10877] 1229 54	[12419] 1403 52		
[16] 61	[1196] 135 82	[2753] 311 80	[4478] 506 79	[6148] 695 78	[7768] 878 77	[9376] 1059 76	[10984] 1241 74			
[20] 76	[1092] 123 102	[2794] 316 101	[4320] 488 101	[6021] 680 99	[7697] 870 97	[9311] 1052 96	[10907] 1232 93			
[24] 91	[1206] 136 123	[2556] 289 122	[4162] 470 120	[5871] 663 119	[7564] 855 118	[9289] 1049 116				
[28] 106	[1083] 122 145	[2338] 264 142	[4040] 456 141	[5666] 640 139	[7365] 832 137	[9022] 1019 135				
[32] 121	[950] 107 163	[2110] 238 162	[3795] 429 162	[5457] 617 159	[7122] 805 159	[8828] 997 156				
[36] 136	[726] 82 184	[1845] 208 183	[3517] 397 182	[5223] 590 181	[6853] 774 179					
[40] 151	[515] 58 203	[2227] 252 202	[3270] 369 202	[4965] 561 201	[6672] 754 199					
[50] 189			[3869] 437 254	[4148] 469 252	[5850] 661 250					
[60] 227				[4856] 549 303	[6604] 746 301					

805 cm ³/r [49.0 in ³/r] Δ Pressure Bar [PSI]

	[250] 15	[500] 35	[750] 50	[1000] 70	[1250] 85	[1500] 105	[1750] 120	[2000] 140	[2250] 155	[2500] 170
[1] 3,8	[1455] 164 4	[3100] 350 4	[4680] 529 2	[6031] 681 2	[7799] 881 1					
[2] 7,5	[1483] 168 9	[3173] 359 9	[5121] 579 9	[6432] 727 8	[8510] 961 7	[9633] 1088 6	[11319] 1279 5	[12127] 1370 5		
[4] 15	[1547] 175 19	[3331] 376 19	[5292] 598 18	[6744] 762 17	[8714] 984 16	[10075] 1138 15	[11352] 1283 14	[12539] 1417 12	[14564] 1645 11	[16377] 1850 10
[8] 30	[1599] 181 35	[3473] 392 35	[5415] 612 34	[7039] 795 33	[8934] 1009 32	[10629] 1201 31	[11842] 1338 29	[14004] 1582 29	[15441] 1745 28	
[12] 45	[1599] 181 56	[3469] 392 56	[5415] 612 55	[7093] 801 53	[9024] 1020 53	[10658] 1204 52	[12283] 1388 50	[13726] 1551 50		
[16] 61	[1543] 174 73	[3395] 384 73	[5357] 605 72	[7032] 794 70	[8983] 1015 69	[10640] 1202 68	[12010] 1357 67			
[20] 76	[1457] 165 93	[3312] 374 92	[5292] 598 91	[6968] 787 89	[8943] 1010 88	[10583] 1196 87	[12146] 1372 86			
[24] 91	[1352] 153 112	[3183] 360 112	[5088] 575 111	[6811] 769 110	[8812] 996 108	[10411] 1176 106				
[28] 106	[1213] 137 131	[3055] 345 131	[5047] 570 131	[6713] 758 129	[8681] 981 128	[10411] 1176 127				
[32] 121	[1075] 121 150	[2907] 328 149	[4884] 552 149	[6546] 740 146	[8395] 949 145	[10060] 1137 144				
[36] 136	[823] 93 168	[2692] 304 168	[4663] 527 168	[6320] 714 167	[8118] 917 165					
[40] 151	[592] 67 187	[2477] 280 186	[4426] 500 186	[6085] 688 185	[7832] 885 184					
[50] 189		[2730] 308 234	[4214] 476 233	[5849] 661 231	[7603] 859 230					
[60] 227			[3806] 430 280	[5459] 617 277	[7407] 837 275					

[6604]
746
301 } Torque [lb-in]
Nm
Speed RPM

6000 Series

985 cm³/r [60.0 in³/r]
D Pressure Bar [PSI]

Performance Data

Motors run with high efficiency in all areas designated with a number for torque and speed. For best motor life select a motor to run with a torque and speed range shown in the light shaded area.

Performance data is typical at 120 SUS. Actual data may vary slightly from unit to unit in production.

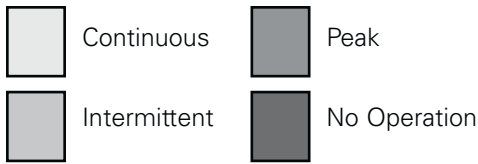

	[250] 15	[500] 35	[750] 50	[1000] 70	[1250] 85	[1500] 105	[1750] 120	[2000] 140
[1] 3.8	[1890] 215 3	[4110] 465 3	[5730] 645 2	[7640] 865 2	[9550] 1080 1			
[2] 7.5	[1910] 215 8	[4140] 470 8	[6270] 710 7	[8300] 940 7	[10420] 1175 6	[12500] 1410 5	[13860] 1565 4	[14920] 1685 3
[4] 15	[1980] 225 15	[4290] 485 15	[6480] 775 15	[8540] 965 14	[10670] 1205 14	[12800] 1445 13	[13900] 1570 13	[15850] 1790 12
[8] 30	[2030] 230 30	[4400] 495 30	[6630] 750 30	[8790] 995 29	[10940] 1235 28	[13090] 1480 27	[14500] 1640 26	[16580] 1875 25
[12] 45	[2020] 230 45	[4390] 495 45	[6630] 750 45	[8860] 1000 44	[11050] 1250 43	[13240] 1495 42	[15040] 1700 41	
[16] 61	[2010] 225 61	[4320] 490 61	[6560] 740 61	[8790] 995 60	[11000] 1245 59	[13260] 1500 58		
[20] 76	[1910] 215 77	[4220] 475 77	[6480] 730 76	[8720] 985 76	[10950] 1235 75	[13160] 1485 74		
[24] 91	[1810] 205 92	[4060] 460 92	[6230] 705 92	[8500] 960 91	[10790] 1220 90	[12990] 1470 89		
[28] 106	[1620] 185 107	[3920] 445 107	[6180] 700 107	[8420] 950 106	[10630] 1200 105	[12820] 1450 103		
[32] 121	[1480] 165 123	[3740] 425 123	[5980] 675 122	[8200] 925 121	[10280] 1160 120			
[36] 136	[1140] 130 138	[3490] 395 138	[5710] 645 138	[7930] 895 137	[9940] 1125 135			
[40] 151	[850] 95 153	[3240] 365 153	[5420] 610 152	[7640] 865 151	[9590] 1085 150			
[50] 189		[2960] 325 191	[5160] 585 190	[7350] 830 189	[9310] 1050 188			
[60] 227			[4660] 525 230	[7160] 810 229	[9070] 1025 226			



6000 Series

Dimensions

Standard Mount

Ports

- 1 5/16 -12 UN-2B SAE O-ring Staggered Ports (2)
- 7/16 -20 UNF-2B SAE O-ring Case Drain Port (1) or
- 4 Bolt 3/4 inch Split Flange Ports (2)
- 7/16 -20 UNF-2B SAE O-ring Case Drain Port (1) or
- G 1 (BSP) Staggered Ports (2)
- G 1/4 (BSP) Case Drain Port (1) or
- 1 5/16 UN-2B SAE O-ring Staggered Ports (2) with Shuttle
- 9/16 -20 UNF-2B SAE O-ring Case Drain Port (1)

Standard Rotation Viewed from Shaft End

- Port A Pressurized — CW
- Port B Pressurized — CCW

Standard Mount

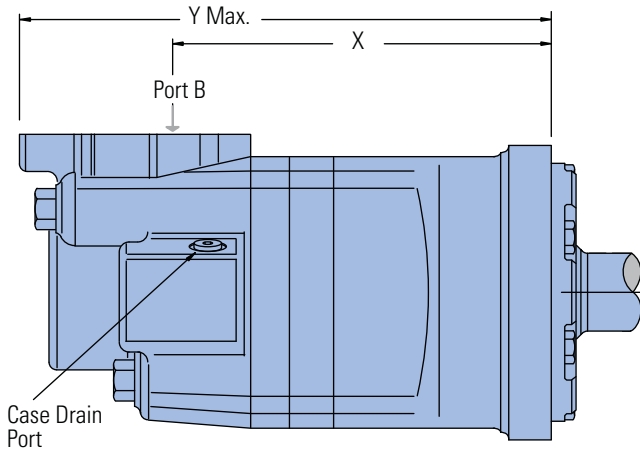

Standard SAE CC Flange

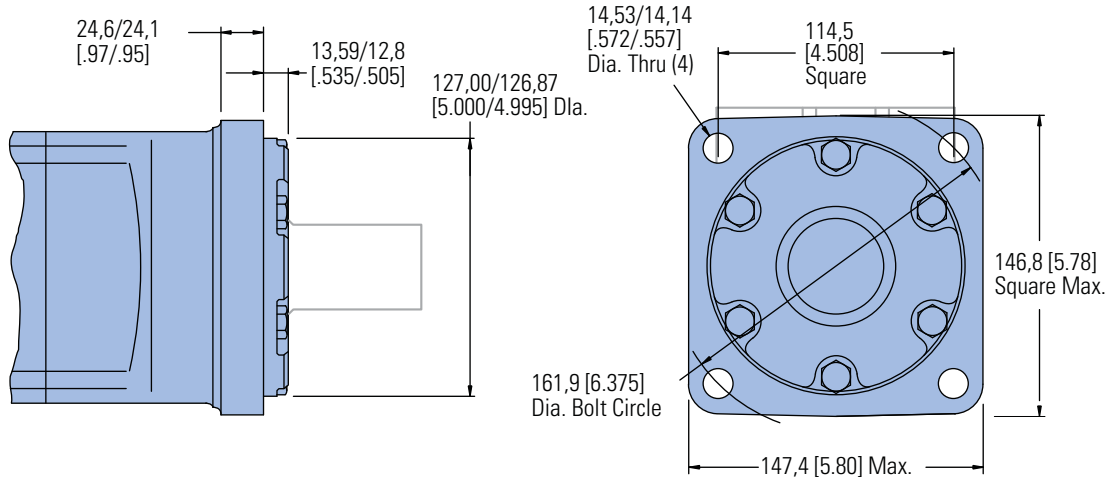

STANDARD MOTOR MOUNT DIMENSIONS

Displacement cm ³ /r [in ³ /r]	X mm [inch]	Y mm [inch]
195 [11.9]	187,5 [7.38]	270,0 [10.63]
245 [15.0]	193,0 [7.60]	275,6 [10.85]
310 [19.0]	200,4 [7.89]	283,0 [11.14]
390 [23.9]	209,0 [8.23]	291,6 [11.48]
490 [30.0]	220,2 [8.67]	302,8 [11.92]
625 [38.0]	235,0 [9.25]	317,5 [12.50]
985 [60.0]	274,6 [10.81]	357,1 [14.06]

6000 Series

Dimensions

Wheel Mount

Ports

- 1 5/16 -12 UN-2B SAE O-ring Staggered Ports (2)
- 7/16 -20 UNF-2B SAE O-ring Case Drain Port (1) or
- 4 Bolt 3/4 inch Split Flange Ports (2)
- 7/16 -20 UNF-2B SAE O-ring Case Drain Port (1) or
- G 1 (BSP) Staggered Ports (2)
- G 1/4 (BSP) Case Drain Port (1) or
- 1 5/16 UN-2B SAE O-ring Staggered Ports (2) with Shuttle
- 9/16 -20 UNF-2B SAE O-ring Case Drain Port (1)

Standard Rotation Viewed from Shaft End

- Port A Pressurized — CW
- Port B Pressurized — CCW

Wheel Mount

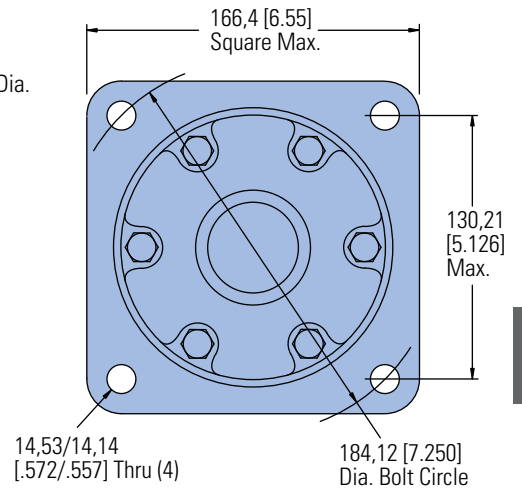
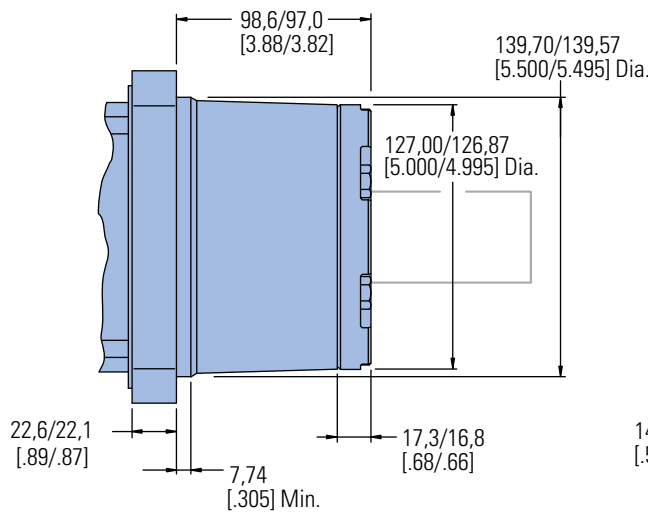
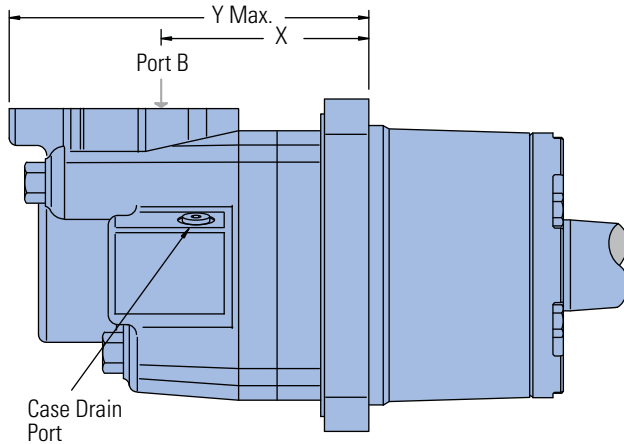

C-5

WHEEL MOUNT MOTOR DIMENSIONS

Displacement cm ³ /r [in ³ /r]	X mm [inch]	Y mm [inch]
195 [11.9]	102,6 [4.04]	185,2 [7.29]
245 [15.0]	108,2 [4.26]	190,8 [7.51]
310 [19.0]	115,6 [4.55]	198,1 [7.80]
390 [23.9]	124,5 [4.90]	207,1 [8.15]
490 [30.0]	135,4 [5.33]	217,9 [8.58]
625 [38.0]	150,1 [5.91]	232,7 [9.16]
985 [60.0]	189,7 [7.47]	272,5 [10.73]

6000 Series

Dimensions

Global Mount (ISO)

Ports

- 1 5/16 -12 UN-2B SAE O-ring Staggered Ports (2)
- 7/16 -20 UNF-2B SAE O-ring Case Drain Port (1) or
- 4 Bolt 3/4 inch Split Flange Ports (2)
- 7/16 -20 UNF-2B SAE O-ring Case Drain Port (1) or
- G 1 (BSP) Staggered Ports (2)
- G 1/4 (BSP) Case Drain Port (1) or
- 1 5/16 UN-2B SAE O-ring Staggered Ports (2) with Shuttle
- 9/16 -20 UNF-2B SAE O-ring Case Drain Port (1)

Standard Rotation Viewed from Shaft End

- Port A Pressurized — CW
- Port B Pressurized — CCW

Global Mount (ISO)

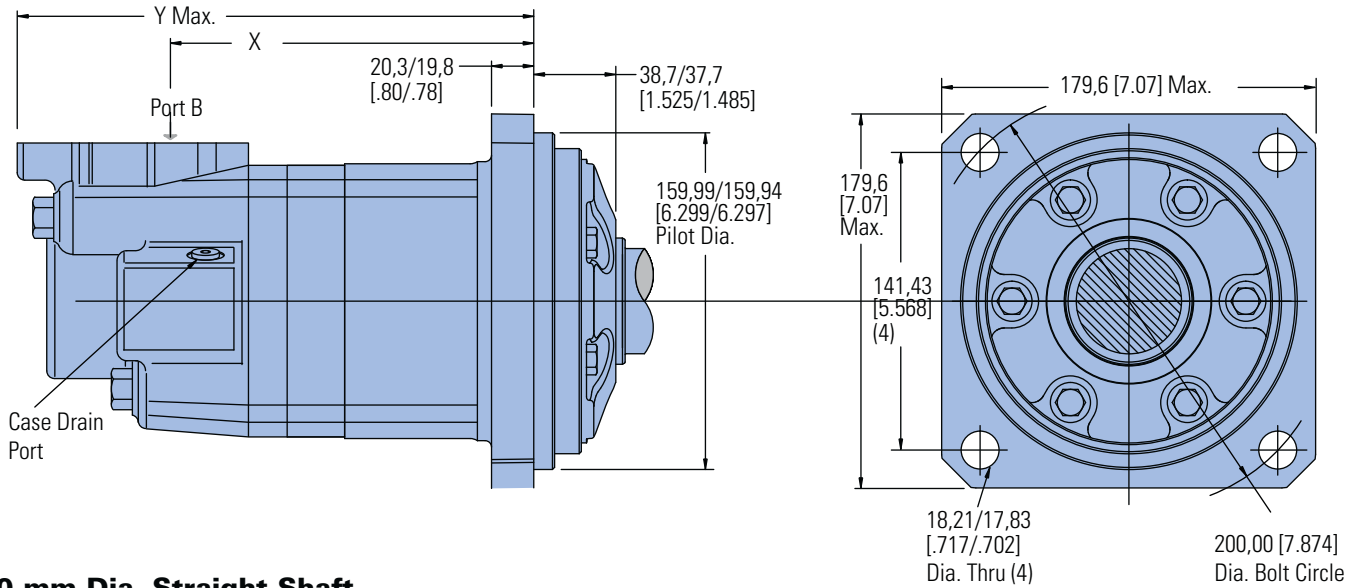

50 mm Dia. Straight Shaft

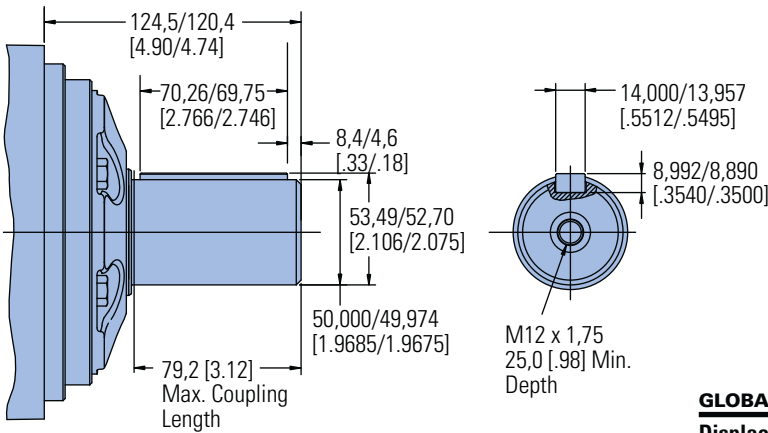

GLOBAL MOUNT MOTOR DIMENSIONS

Displacement cm ³ /r [in ³ /r]	X mm [inch]	Y mm [inch]
310 [19.0]	182,4 [7.18]	264,9 [10.43]
390 [24.0]	191,0 [7.52]	273,6 [10.77]
490 [30.0]	202,2 [7.96]	284,7 [11.21]
625 [38.0]	216,9 [8.54]	299,5 [11.79]
800 [45.0]	229,4 [9.03]	312,2 [12.29]
800 [49.0]	236,7 [9.32]	319,3 [12.57]
985 [60.0]	256,5 [10.10]	339,1 [13.35]

6000 Series

Dimensions

Bearingless

Ports

- 1 5/16 -12 UN-2B SAE O-ring Staggered Ports (2)
- 7/16 -20 UNF-2B SAE O-ring Case Drain Port (1) or
- 4 Bolt 3/4 inch Split Flange Ports (2)
- 7/16 -20 UNF-2B SAE O-ring Case Drain Port (1) or
- G 1 (BSP) Staggered Ports (2)
- G 1/4 (BSP) Case Drain Port (1) or
- 1 5/16 UN-2B SAE O-ring Staggered Ports (2) with Shuttle
- 9/16 -20 UNF-2B SAE O-ring Case Drain Port (1)

Bearingless

Standard Rotation Viewed from Shaft End

- Port A Pressurized — CW
- Port B Pressurized — CCW

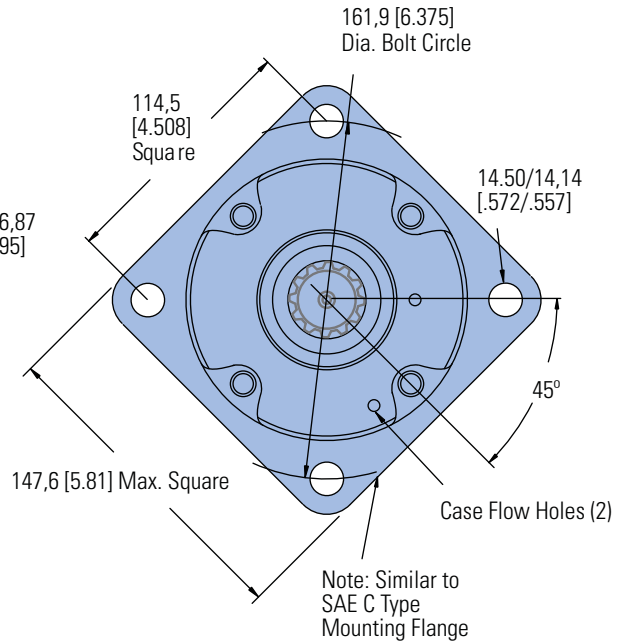
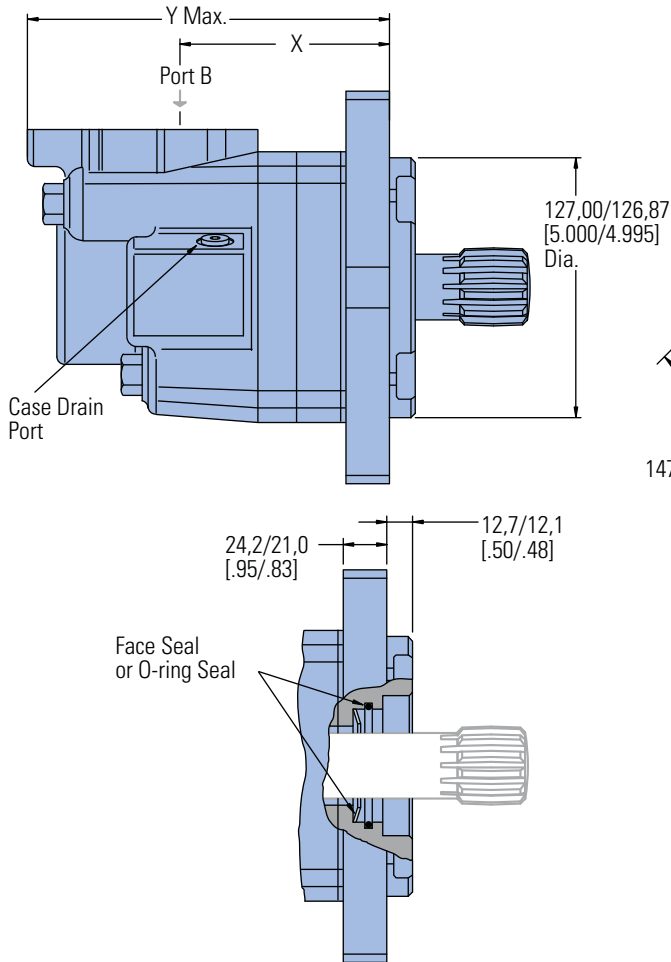

For 6000 bearingless motor application information, contact your Eaton representative (mating coupling blanks available from Eaton Hydraulics).

Note:

After machining blank, part must be hardened per Eaton specification.

- C 47,2 [1.86] Dia.
- D 111,5 [4.39] Max.
- E 106,4 [4.19] Full Form Dia.
- F 6,9 [.27] Min. Full Form Dia.
- G 10,2 [.40] Min.
- H 86,1 [3.39] Max.
- J 66,5 [2.62] Dia.

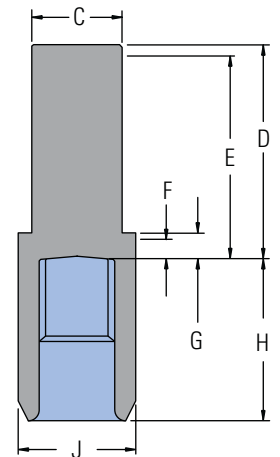

Mating Coupling Blank
Eaton Part No. 12778-002

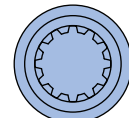

BEARINGLESS MOTOR DIMENSIONS

Displacement cm ³ /r [in ³ /r]	X mm [inch]	Y mm [inch]
195 [11.9]	105,4 [4.15]	188,0 [7.40]
245 [15.0]	111,0 [4.37]	193,5 [7.62]
310 [19.0]	118,4 [4.66]	200,9 [7.91]
390 [23.9]	127,3 [5.01]	209,6 [8.25]
490 [30.0]	138,2 [5.44]	220,7 [8.69]
625 [38.0]	152,9 [6.02]	235,5 [9.27]
985 [60.0]	192,8 [7.59]	275,1 [10.83]

C-5

6000 Series

Installation Information

Bearingless

- 1 Internal spline in mating part to be as follows: Material to be ASTM A304, 8620H. Carbonize to a hardness of 60-64 HRc with case depth (to 50HRc) of 0,076 - 1,02 [.030 - .040] (dimensions apply after heat treat).
- 2 Mating part to have critical dimensions as shown. Oil holes must be provided and open for proper oil circulation.
- 3 Seal to be furnished with motor for proper oil circulation thru splines.

- 4 Some means of maintaining clearance between shaft and mounting flange must be provided.
- 5 Similar to SAE "C" Four Bolt Flange..
- 6 Counterbore designed to adapt to a standard sleeve bearing 50,010 - 50,038 [1.9689 - 1.9700] ID by 60,051 - 60,079 [2.3642 - 2.3653] O.D. (Oilite bronze sleeve bearing).

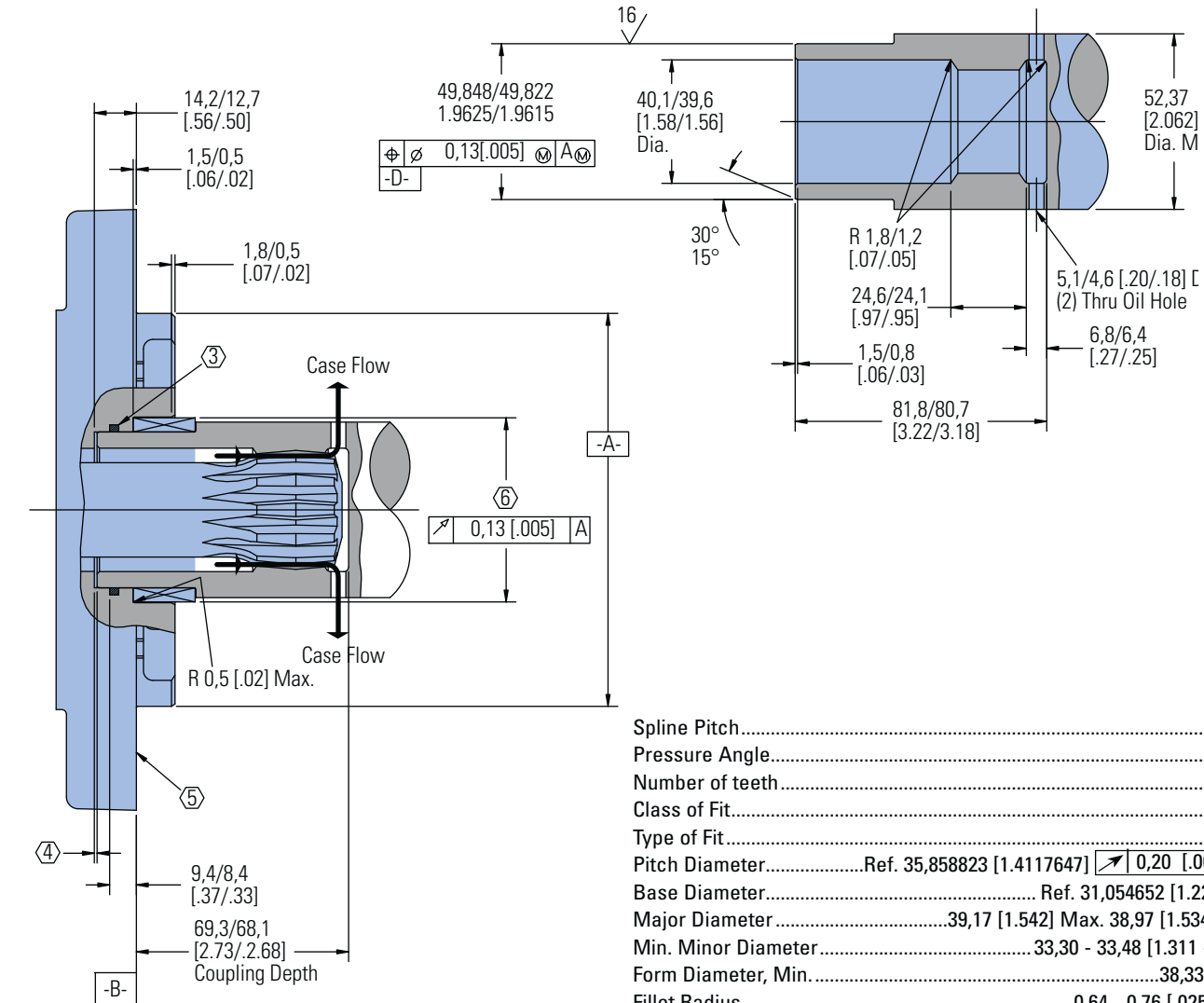

Spline Pitch.....	8.5/17
Pressure Angle.....	30°
Number of teeth.....	12
Class of Fit.....	Ref. 5
Type of Fit.....	Side
Pitch Diameter.....	Ref. 35,858823 [1.4117647] $\begin{matrix} \nearrow & 0,20 & [.008] \\ \square & & \square \end{matrix}$ D
Base Diameter.....	Ref. 31,054652 [1.2226241]
Major Diameter.....	39,17 [1.542] Max. 38,97 [1.534] Min..
Min. Minor Diameter.....	33,30 - 33,48 [1.311 - 1.318]
Form Diameter, Min.....	38,33 [1.509]
Fillet Radius.....	0,64 - 0,76 [.025 - .030]
Tip Radius.....	0,25 - 0,51 [.010 - .020]
Finish.....	1,6 (63)
Involute Profile Variation.....	+0,000 -0,025 [+0.0000 -0.0010]
Total Index Variation.....	0,038 [.0015]
Lead Variation.....	0,013 [.0005]
Circular Space Width:	
Maximum Actual.....	5,898 [.2322]
Minimum Effective.....	5,804 [.2285]
Maximum Effective.....	Ref. 5,857 [.2306]
Minimum Actual.....	Ref. 5,834 [.2297]
Dimension Between Two Pins.....	Ref. 26,929 - 27,084 [1.0602 - 1.0663]
Pin Diameter.....	6,223 [.2450] Pins to Have 4,0 [.160]
	Wide Flat for Root Clearance

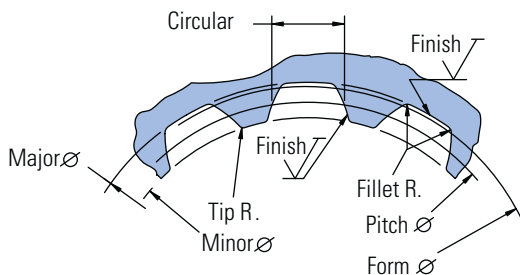

6000 Series

Dimensions

Shafts Splined

1 1/2 Inch Straight

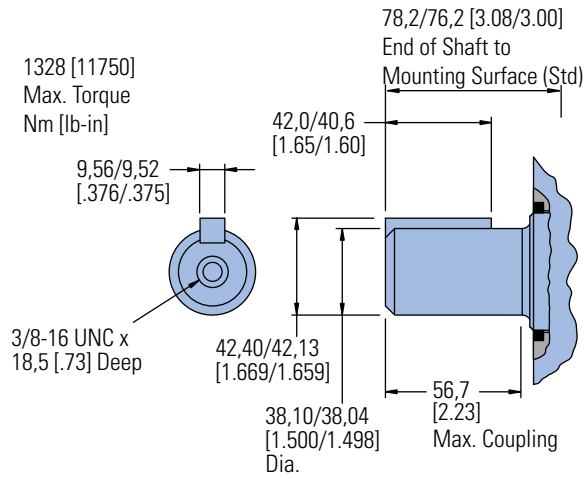

1 3/4 Inch Tapered

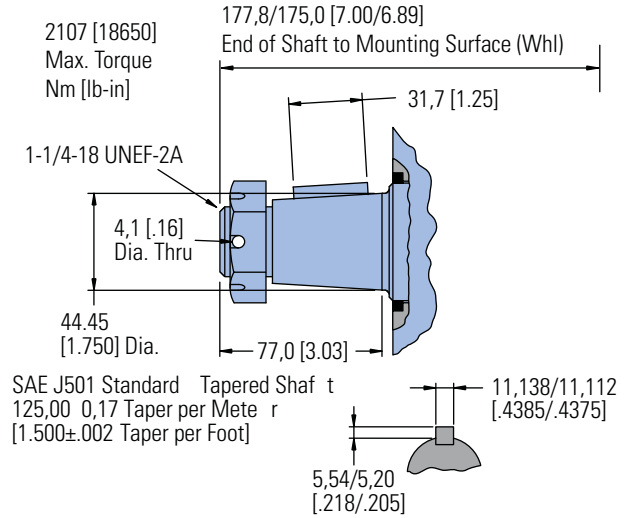

1 1/2 Inch 17 Tooth Splined

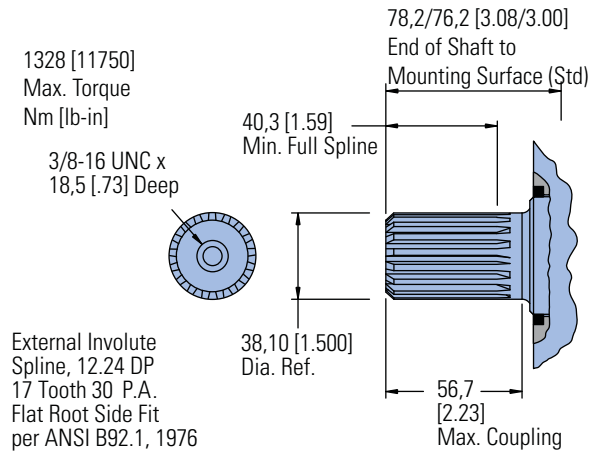

Tapered Shaft Hub Data

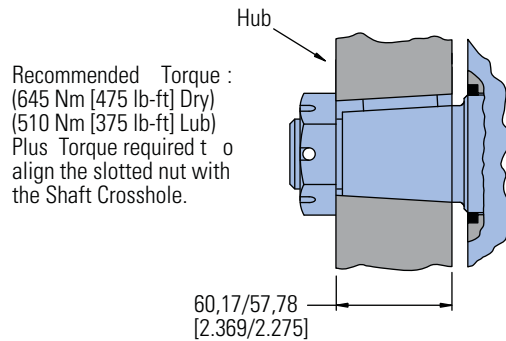

40 mm Straight

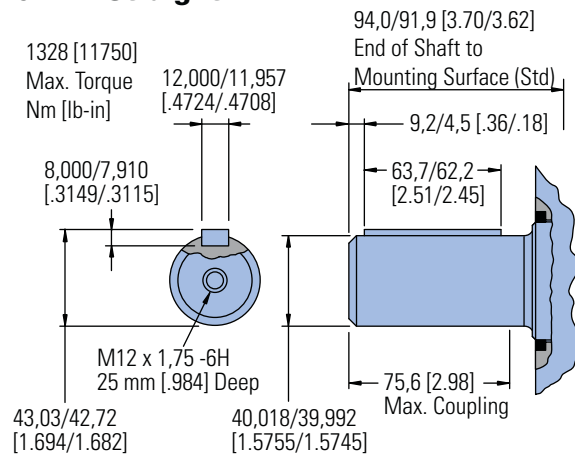

Slotted Hexagon Nut

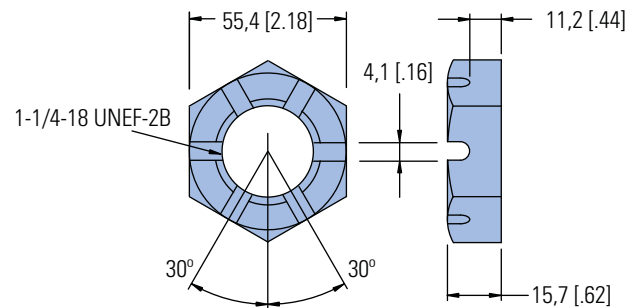

6000 Series

Shaft Side Load Capacity

These curves indicate the radial load capacity on the motor shaft(s) at various locations with an external thrust load of 454 kg [1000 lb]. The maximum allowable thrust load is 908 kg [2000 lb].

Note:

Case pressure will increase the allowable inward thrust load and decrease the allowable outward thrust load. Case pressure will push outward on the shaft at 109 kg/7 Bar [241 lb/100 PSI].

Each curve is based on

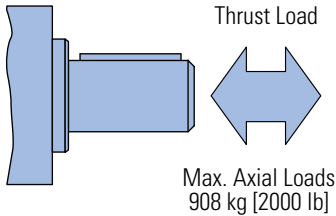

B 10 bearing life (2000 hours of 12,000,000 shaft revolutions at 100 RPM) at rated output torque.

To determine radial load at speeds other than 100 RPM, multiply the load values given on the bearing curve by the factors in the chart below.

RPM	Multiplication Factor
50	1.23
100	1.00
200	0.81
300	0.72
400	0.66
500	0.62
600	0.58
700	0.56
800	0.54

For 3,000,000 shaft revolutions or 500 hours—Increase these shaft loads 52%.

Standard Motor
Straight and Splined Shafts

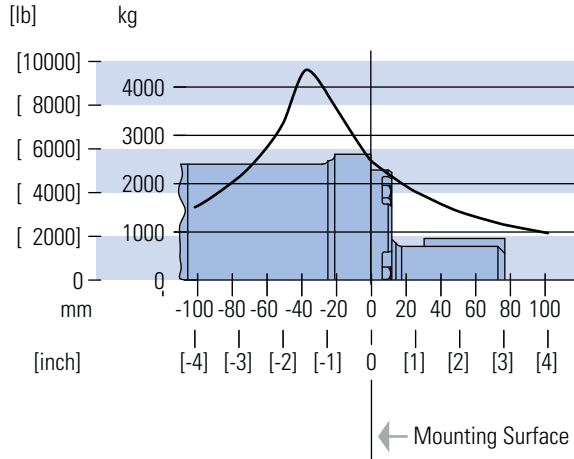

Wheel Motor Tapered Shaft

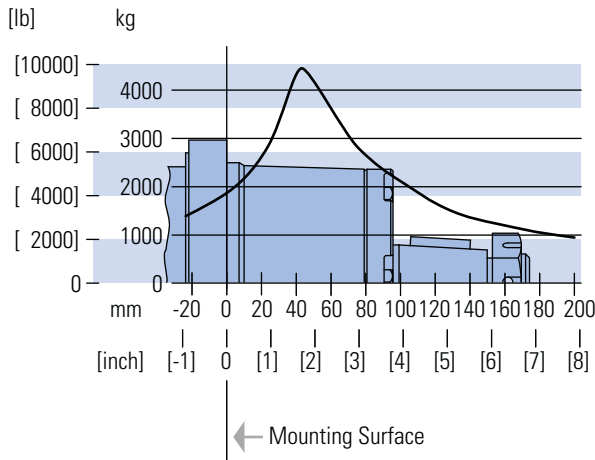

6000 Series

Case Pressure and Case Port

Char-Lynn 6000 Series motors are durable and have long life as long as the recommended case pressure is not exceeded. Allowable case pressure is highest at low shaft speeds. Consequently, motor life will be shortened if case pressure exceeds these ratings (acceptability may vary with application). Determine if an external case drain is required from the case pressure seal limitation chart.

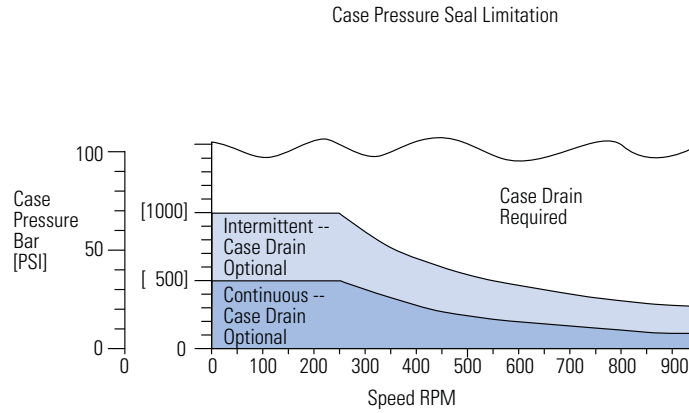

Case Porting Advantage

Contamination Control — flushing the motor case.

Cooler Motor — exiting oil draws motor heat away.

Extend Motor Seal Life — maintain low case pressure with a preset restriction in the case drain line.

6000 Series

Dimensions

Ports

1 5/16 -12 O-ring Ports (2) or G 1 (BSP) Ports (2)

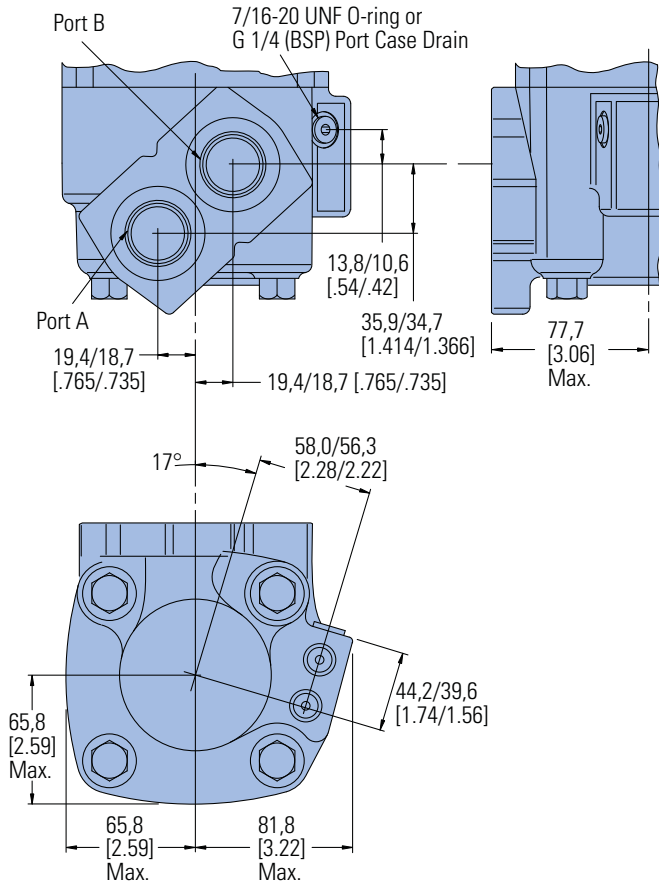

4 Bolt 3/4 Inch Split Flange

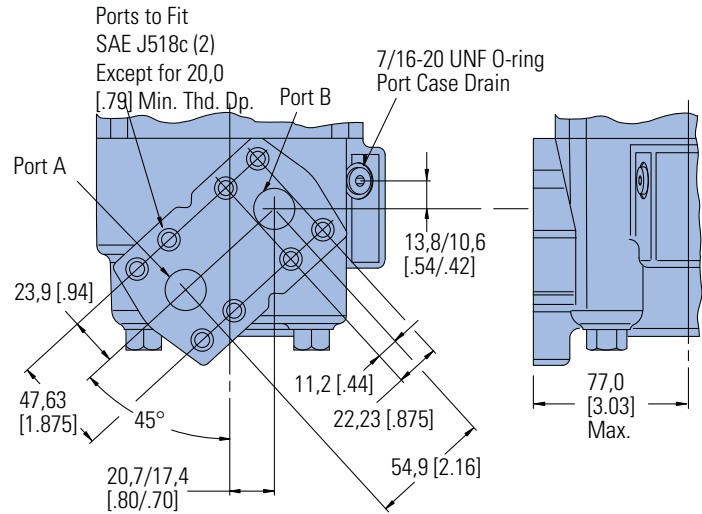

1 5/16 -12 O-ring Ports (2) with Shuttle

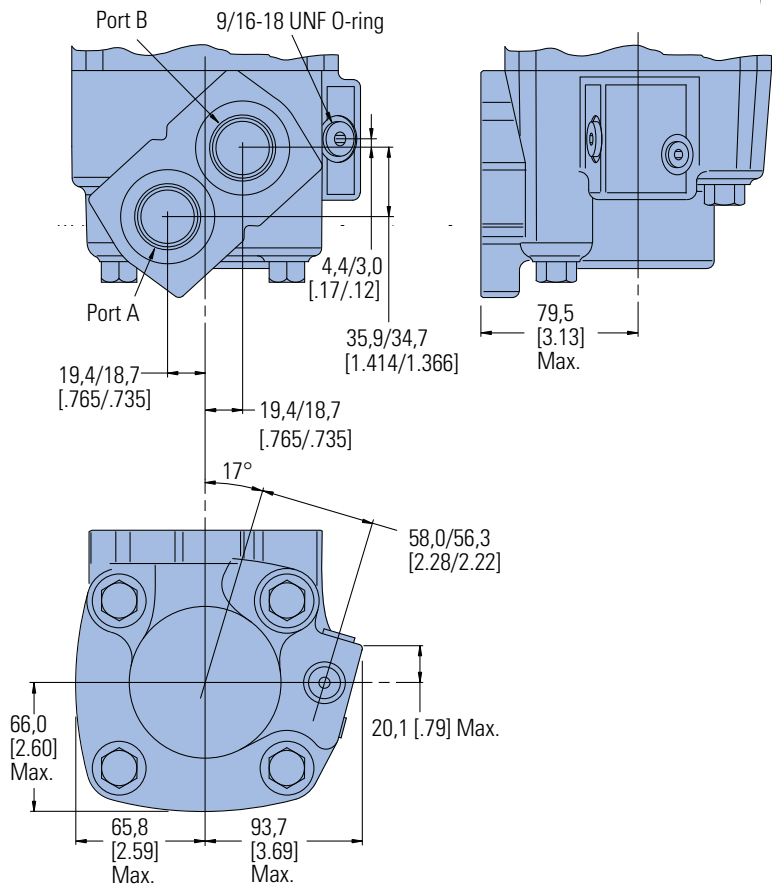

6000 Series

Product Numbers

Note:

For 6000 Series Motors with a configuration **Not Shown** in the charts above: Use model code number system on the next page to specify product in detail.

Use digit prefix — 112-, 113-, or 114 - plus four digit number from charts for complete product number— Example 114-1047.

Orders will not be accepted without three digit prefix.

MOUNTING	SHAFT	PORT SIZE	DISPL. cm ³ /r [in ³ /r] / PRODUCT NUMBER								
			195 [11.9]	245 [15.0]	310 [19.0]	390 [23.9]	490 [30.0]	625 [38.0]	735* [45.0]	805* [49.0]	985 [60.0]
Standard	1 1/2 inch Straight	1 5/16 O-ring	112-1064	-1065	-1066	-1067	-1068	-1107	-1145	—	-1069
	40 mm Straight	G 1 (BSP)	112-1094	-1095	-1096	-1097	-1098	—	—	—	-1099
	1 1/2 Inch 17 T Splined	1 5/16 O-ring	112-1058	-1059	-1060	-1061	-1062	-1109	1163	—	-1063
		G 1 (BSP)	112-1088	-1089	-1090	-1091	-1092	—	—	—	-1093
Wheel Motor	40 mm Straight	G 1 (BSP)	113-1082	-1083	-1084	-1085	-1086	-1100	—	—	-1087
	1-3/4 Inch Tapered	1 5/16 O-ring	113-1070	-1071	-1072	-1073	-1074	-1093	—	—	-1075
Bearingless		1 5/16 O-ring	114-1031	-1032	-1033	-1034	-1035	-1055	—	—	-1036
	G 1 (BSP)	114-1043	-1044	-1045	-1046	-1047	—	—	—	-1048	

*New release

114-1047

Mounting Type - Standard (Code H), 4 Bolt:

- 160,0 [6.30] Pilot Dia.
- 18,01 [.709] Dia. Mounting Holes
- 200,0 [7.87] Dia. Bolt Circle

Output Shaft - Straight (Code 21)

Ports - G1 (BSP) Staggered G 1/4 Case Drain (Code C)

Paint - Low Gloss Black (Code A)

Use digit prefix — 112- plus four digit number from charts for complete product number— Example 112-1215.

Orders will not be accepted without three digit prefix.

MOUNTING	SHAFT	PORT SIZE	DISPL. cm ³ /r [in ³ /r] / PRODUCT NUMBER						
			310 [19.0]	390 [23.9]	490 [30.0]	625 [38.0]	735 [45.0]	805 [49.0]	985 [60.0]
Standard	50 mm Straight	G 1 (BSP)	112-1217	-1218	-1215	-1216	-1247	-1219	-1220

112-1215

6000 Series

Model Code

The following 30-digit coding system has been developed to identify all of the configuration options for the 6000 Series motor. Use this model code to specify a motor with the desired features. All 30-digits of the code must be present when ordering. You may want to photocopy the matrix below to ensure that each number is entered in the correct box.

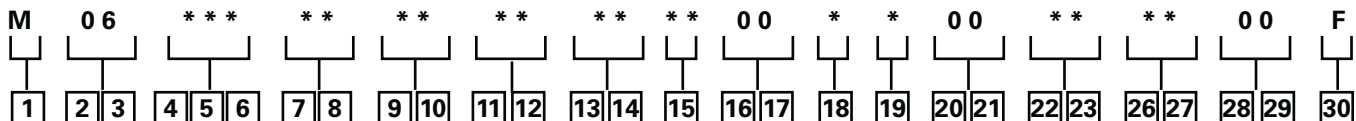

1 Product
M – Motor

2, **3** Series
06 – 6000 Series

4, **5**, **6** Displacement
cm³/r [in³/r]

120 – 195.8 [11.95]
150 – 246.5 [15.04]
190 – 312.0 [19.04]
239 – 391.7 [23.90]
300 – 491.4 [29.99]
381 – 624.2 [38.09]
450 – 737.4 [45.00]
490 – 803.4 [49.03]
600 – 982.7 [59.97]

7, **8** Mounting Type
AA – Bearingless, 4 Bolt:
127,0 [5.00] Pilot Dia. and
14,35 [.565] Dia. Holes
162,0 [6.38] Dia. Bolt Circle
AB – Standard, 4 Bolt (SAE
CC): **127,0** [5.00] Pilot Dia.
and **14,35** [.565] Dia. Holes
on **162,0** [6.38] Dia. B.C.

AC – Wheel, 4 Bolt **139,7**
[5.50] Pilot Dia. and **14,35**
[.565] Dia. Holes on **184,2**
[7.25] Dia. Bolt Circle

AD – Standard, 4 Bolt, (SAE
D): **152,4** [6.00] Pilot Dia.
15,24 [.600] Dia. Holes on
228,6 [9.00] Dia. Bolt Circle
(SAE D) with O-Ring Groove
to Accept ARP-163 O-Ring
AH – Standard, 4 Bolt: **10,0**
[6.30] Pilot Dia. **18,01** [.709]
Dia. Holes on **200,0** [7.87]
Dia. Bolt Circle.

AL - Wheel, 4 Bolt: **160,0**
[6.30] Pilot Dia. with **5,8** [.23]
Pilot Length and **18,00** [.709]
Dia. Holes on **200,0** [7.874]
Bolt Circle (ISO Compatible)

9, **10** Output Shaft
Description
00 – None (Bearingless)
01 – **38,10** [1.50] Dia.
Straight Shaft with **.375-16**
UNC-2B Thread in End, **9,52**
[.375] Sq. x **41,28** [1.625]
Straight Key
02 – **44,45** [1.75] Dia. **.125:1**
Tapered Shaft per SAE
J501 with **1.25-18** UNEF-2A
Threaded Shaft End, **11,11**
[.4375] Sq. x **31,8** [1.25]
Straight Key
03 – **38,10** [1.50] Dia. Flat
Root Side Fit, **17** Tooth,
12/24 DP **30** DEG. Involute
Spline with **.375-16** UNC-2B
Thread in end **40,4** [1.59]
Minimum Full Spline
Length

04 – **40,00** [1.575] Dia.
Straight Shaft with **M12 x**
1.75-6H Thread in End, **12W**
x 8H x 63L [.472W x .313H x
2.480L] Key
12 – **49,99** [1.968] Dia.
Straight Shaft with **M12 x**
1.75-6H Thread in End, **14W**
x 9H x 70L [.550W x .354H x
2.756L] Key

15 – 60mm Dia. 10:1 Tapered
Shaft per ISO R775 with **M42**
x 3-6H Threaded Shaft End,
16W x 10H x 32L [.630W x
.394H x 1.26L] Key

16 – **53,98** [2.125] Dia. Flat
Root Side Fit, **16** Tooth, **8/16**
DP **30** Deg. Involute Spline
with **M12 x 1.75-6H** Thread
in End, **55,9** [2.20] Min Full
Spline

11, **12** Port Description
AA – **1,3125-12** UN-2B SAE
O-Ring Ports–Staggered
Ports
AB – SAE **19.05** [.750]
Dia. 4-Bolt Split Flange -
Staggered Ports
AC – **G 1** Staggered Ports
AG – **.750-16** UNF-2B SAE
O-ring Ports - Staggered

13, **14** Case Flow
02 – **.4375-20** UNF-2B SAE
O-Ring Port With Check
Valve
03 – **G 1/4** BSP Straight
Thread Port with Check
Valve
06 – **.5625-18** UNF-2B SAE
O-Ring Port with Shuttle Valve
10 – **.750-16** UNF-2B SAE
O-ring Ports, External
Lubrication Circuit Requires
Case Drain must be
Connected, **.063** Shuttle Flow
Orifice

15 Low Pressure Relief
0 – None
A – Set at **4.5** [65 lbf/in²]
B – Set at **15.2** [220 lbf/in²]

16, **17** Pressure/Flow
Option
00 – None

18 Geroler Option
0 – Standard
2 – Tight Fitting

19 Seal Option
0 – Standard
1 – Viton
3 – Seal Guard

20, **21** Accessories
00 – None

22, **23** Special Features
(Hardware)
00 – None
01 – Non-Masked
Nameplate
02 – Non-Masked Nameplate,
Low Noise Valve Plate
03 – Low Noise Valve Plate

24, **25** Special Features
(Assembly)
00 – None
AA – Reverse Rotation

26, **27** Paint/Packaging
00 – No Paint, Individual
Box
AA – Low Gloss Black
Primer
AD – No Paint, Bulk Box
Option
AE – Low Gloss Black
Primer, Bulk Box
Option

28, **29** Customer ID
00 – None

30 Design Code
F – Sixth

Feature in bold are preferred
and allow for shorter lead time