

Hydrostatic Pump Repair

www.hydrostaticpumprepair.net

Phone: 800-361-0028

Email: sales@hydrostatic-transmission.com

Rexroth
Bosch Group

Axial Piston Variable Pump A10VG

RE 92750/06.09

1/44

Replaces: 03.09

Data sheet

Series 10
Sizes 18...63
Nominal pressure 300 bar
Peak pressure 350 bar
Closed circuit

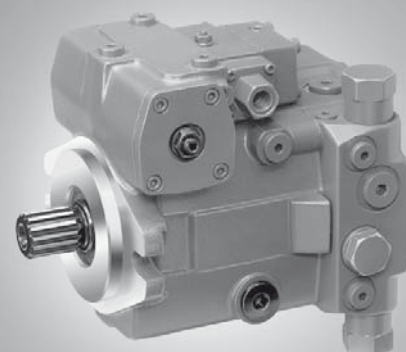

Contents

Ordering Code / Standard Program	2
Technical Data	5
High-Pressure Relief Valves	9
Pressure Cut-Off, D	10
DG - Hydraulic Control, Direct Operated	10
MD - Mechanical Pivot Control (Size 18 only)	11
HD - Hydraulic Control, Pilot-Pressure Related	12
HW - Hydraulic Control, Mechanical Servo	13
DA - Hydraulic Control, Speed Related	14
EP - Electric Control, With Proportional Solenoid	16
EZ - Electric Two-Point Control, With Switching Solenoid	18
Unit Dimensions, Size 18	19
Unit Dimensions, Size 28	22
Unit Dimensions, Size 45	26
Unit Dimensions, Size 63	30
Through Drive Dimensions	34
Overview of Attachments on A10VG	36
Combination Pumps A10VG + A10VG	36
Mechanical Stroke Limiter, M	37
Filtration Types	38
Connector for Solenoids (Only for EP, EZ, DA)	39
Rotary Inch Valve	40
Installation Situation for Coupling Assembly	41
Installation Notes	42
General Notes	44

Features

- Variable axial piston pump of washplate design for hydrostatic closed circuit transmission
- Flow is proportional to drive speed and displacement and is infinitely variable
- Output flow increases with the swivel angle of the washplate from 0 to its maximum value
- Flow direction changes smoothly when the washplate is moved through the neutral position
- A wide range of highly adaptable control devices is available for different control and regulating functions
- The pump is equipped with two pressure-relief valves on the high pressure ports to protect the hydrostatic transmission (pump and motor) from overload
- The high-pressure relief valves also function as boost valves
- The integrated boost pump acts as a feed and control oil pump
- The maximum boost pressure is limited by a built-in boost pressure relief valve

Ordering Code / Standard Program

A10V	G									/	10			-	N		C							
01	02	03	04	05	06	07	08	09			10	11			12	13	14	15	16	17	18	19	20	21

Axial piston unit

01	Variable swashplate design, nominal pressure 300 bar, peak pressure 350 bar	A10V
----	---	-------------

Operation mode

02	Pump in closed circuit	G
----	------------------------	----------

Size

03	≈ Displacement $V_{g\ max}$ in cm^3	18	28	45	63
----	---------------------------------------	-----------	-----------	-----------	-----------

Control device

			18	28	45	63		
	Mechanical pivot control		●	-	-	-	MD	
04	Hydraulic control	pilot-pressure related, with supply filtration	●	●	●	●	HD3	
		mechanical servo	●	●	●	●	HW	
		direct operated	●	●	●	●	DG	
		speed related						
		(Description DA control valve in Pos. 09)	U = 12 V DC	-	●	●	●	DA1
		U = 24 V DC	-	●	●	●	DA2	
04	Electric control	with proportional solenoid, with supply filtration	U = 12 V DC	●	●	●	●	EP3
			U = 24 V DC	●	●	●	●	EP4
		with switching solenoid	U = 12 V DC	●	●	●	●	EZ1
			U = 24 V DC	●	●	●	●	EZ2

Pressure cut-off

		18	28	45	63	
05	Without pressure cut-off (not for DA, without code)	●	●	●	●	
	With pressure cut-off	-	●	●	●	D

Neutral position switch (only for HW)

		18	28	45	63	
06	Without neutral position switch (without code)	●	●	●	●	
	With neutral position switch (with DEUTSCH connector)	●	●	●	●	L

Mechanical stroke limiter

		18	28	45	63	
07	Without mechanical stroke limiter (without code)	●	●	●	●	
	With mechanical stroke limiter, external variable	●	●	●	●	M

Spring centering of neutral position (only MD)

		18	28	45	63	
08	Without spring centering of neutral position (without code)	●	-	-	-	
	With spring centering of neutral position	●	-	-	-	N

Ordering Code / Standard Program

A10V	G									/	10		-	N		C								
01	02	03	04	05	06	07	08	09			10	11		12	13	14	15	16	17	18	19	20	21	

DA control valve (only for size 28-63)		HD	HW	DG	DA	EP	EZ		
09	Without DA control valve	●	●	●	-	●	●	1	
	With DA control valve, fixed setting	●	●	●	●	●	-	2	
	With DA control valve, mech. adjustable with position lever	Actuating direction - clockwise	●	●	●	●	●	-	3R
		Actuating direction - counterclockwise	●	●	●	●	●	-	3L
	With DA control valve, fixed setting and hydraulic inch valve mounted, control with brake fluid according to ISO 4925, no mineral oil	-	-	-	●	-	-	-	4
	With DA control valve, fixed setting and ports for pilot control device	●	●	●	●	●	-	-	7
With DA control valve, fixed setting and hydraulic inch valve mounted, control with brake fluid based on mineral oil	-	-	-	●	-	-	-	8	

Series

10	Series 1, Index 0	10
----	-------------------	-----------

Direction of rotation

11	Viewed from shaft end	clockwise	R
		counterclockwise	L

Seals

12	NBR (nitrile-caoutchouc), shaft seal ring in FKM (fluor-caoutchouc)	N
----	---	----------

Shaft end (permissible input torque see page 8)

		18	28	45	63	
13	Splined shaft for single pump	●	●	●	●	S
	ANSI B92.1 a-1976 for combination pump	-	-	●	●	T

Mounting flange

14	SAE J744 – 2-bolt	C
----	-------------------	----------

Service line ports (metric fixing thread)

		18	28	45	63	
15	SAE flange ports A/B, same side left, suction port S bottom	-	●	●	●	10
	A/B threaded ports, same side right, suction port S bottom	●	-	-	-	16

Boost pump

		18	28	45	63		
16	Without integrated boost pump	without through drive	●	●	●	●	N00
		with through drive	●	●	●	●	K..
	With integrated boost pump	without through drive	●	●	●	●	F00
		with through drive	●	●	●	●	F..

Through drive (mounting options, see page 36)

		18	28	45	63		
17	Flange SAE J744 ¹⁾	Hub for splined shaft					
	82-2 (A)	5/8 in	9T 16/32DP ²⁾	●	●	●	.01
	101-2 (B)	7/8 in	13T 16/32DP ²⁾	●	●	●	.02
		1 in	15T 16/32DP ²⁾	-	●	●	.04
	127-2 (C)	1 1/4 in	14T 12/24DP ²⁾	-	-	●	.07

Ordering Code / Standard Program

A10V	G								/	10			-	N		C										
01	02	03	04	05	06	07	08	09		10	11		12	13	14	15	16	17	18	19	20	21				

Valves		setting range Δp	18	28	45	63	
18	With high-pressure relief valve, direct operated, (fixed setting)	250...320 bar without bypass	●	●	●	●	3
		with bypass	●	●	●	●	5
	100...250 bar	without bypass	●	●	●	●	4
		with bypass	●	●	●	●	6

Filtration			18	28	45	63	
19	Filtration in the suction line of boost pump (filter not included in supply)		●	●	●	●	S
	Filtration in the pressure line of boost pump, ports for external boost circuit filtration, (F_e and F_a)		-	● ³⁾	● ³⁾	●	D
	External supply (version without integral boost pump - N00. K...)		●	●	●	●	E

Connector for solenoids (only for EP, EZ and DA)			18	28	45	63	
20	DEUTSCH connector	without suppressor diode	●	●	●	●	P
	molded, 2-pin	with suppressor diode (only for EZ and DA)	○	○	○	○	Q

Standard / special version			
21	Standard version	without code	
		combined with attachment part or attachment pump	-K
	Special version		-S
		combined with attachment part or attachment pump	-SK

¹⁾ 2 = 2-bolt

²⁾ Hub for splined shaft acc. to ANSI B92.1 a-1976 (splined shaft assignment acc. to SAE J744, see page 34-35)

³⁾ Pressure filtration is not possible in conjunction with DA control valve

● = available ○ = on request - = not available

= preferred program

Technical Data

Hydraulic fluid

Before starting project planning, please refer to our data sheets RE 90220 (mineral oil), RE 90221 (environmentally acceptable hydraulic fluids) and RE 90223 (HF hydraulic fluids) for detailed information regarding the choice of hydraulic fluid and application conditions.

The variable pump A10VG is unsuitable for operation with HFA, HFB and HFC. If HFD or environmentally acceptable hydraulic fluids are being used, the limitations regarding technical data and seals mentioned in RE 90221 and RE 90223 must be observed.

When ordering, please indicate the used hydraulic fluid.

Operating viscosity range

For optimum efficiency and service life, select an operating viscosity (at operating temperature) within the optimum range of

$$v_{\text{opt}} = \text{opt. operating viscosity } 16 \dots 36 \text{ mm}^2/\text{s}$$

depending on the circuit temperature (closed circuit).

Limits of viscosity range

The limiting values for viscosity are as follows:

$$v_{\text{min}} = 5 \text{ mm}^2/\text{s}$$

short term ($t < 3 \text{ min}$)
at max. perm. temperature of $t_{\text{max}} = +115 \text{ }^\circ\text{C}$.

$$v_{\text{max}} = 1600 \text{ mm}^2/\text{s}$$

short term ($t < 3 \text{ min}$)
at cold start ($p \leq 30 \text{ bar}$, $n \leq 1000 \text{ rpm}$, $t_{\text{min}} = -40 \text{ }^\circ\text{C}$).
Only for starting up without load. Optimum operating viscosity must be reached within approx. 15 minutes.

Note that the maximum hydraulic fluid temperature of $115 \text{ }^\circ\text{C}$ must not be exceeded locally either (e.g. in the bearing area). The temperature in the bearing area is - depending on pressure and speed - up to 5 K higher than the average case drain temperature.

Special measures are necessary in the temperature range from $-40 \text{ }^\circ\text{C}$ to $-25 \text{ }^\circ\text{C}$ (cold start phase), please contact us.

For detailed information about use at low temperatures, see RE 90300-03-B.

Selection diagram

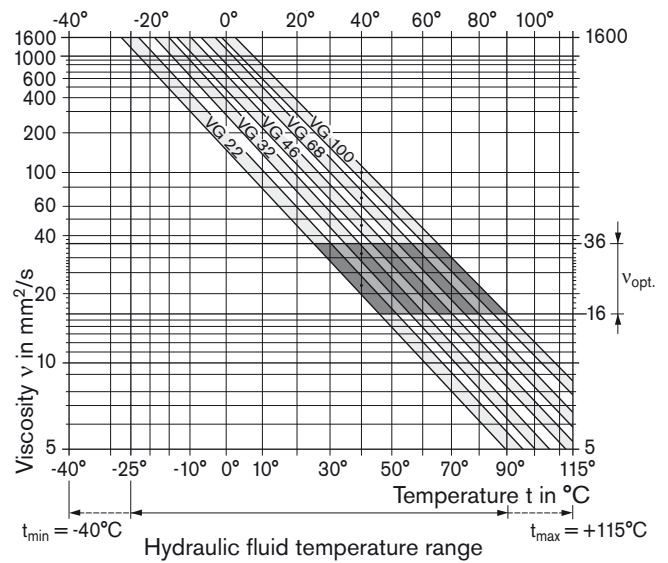

Details regarding the choice of hydraulic fluid

The correct choice of hydraulic fluid requires knowledge of the operating temperature in relation to the ambient temperature: in a closed circuit the circuit temperature.

The hydraulic fluid should be chosen so that the operating viscosity in the operating temperature range is within the optimum range (v_{opt}) - the shaded area of the selection diagram. We recommended that the higher viscosity class be selected in each case.

Example: At an ambient temperature of $X \text{ }^\circ\text{C}$ an operating temperature of $60 \text{ }^\circ\text{C}$ is set. In the optimum operating viscosity range (v_{opt} ; shaded area) this corresponds to the viscosity classes VG 46 or VG 68; to be selected: VG 68.

Please note: The case drain temperature, which is affected by pressure and speed, is always higher than the circuit temperature. At no point in the system may the temperature be higher than $115 \text{ }^\circ\text{C}$.

If the above conditions cannot be maintained due to extreme operating parameters, please consult us.

Technical Data

Filtration

The finer the filtration, the higher the cleanliness level of the hydraulic fluid and the longer the service life of the axial piston unit.

To ensure functional reliability of the axial piston unit the hydraulic fluid must have a cleanliness level of at least

20/18/15 according to ISO 4406.

Depending on the system and the application, for the A10VG, we recommend

Filter elements $\beta_{20} \geq 100$

With a rising differential pressure at the filter elements, the β -value must not deteriorate.

At very high hydraulic fluid temperatures (90 °C to max. 115 °C) at least cleanliness level

19/17/14 according to ISO 4406 is required.

If the above classes cannot be observed, please contact us. For notes on filtration types, see page 38.

Operating pressure range

Input

Variable pump (with external supply, E):

For control EP, EZ, HW and HD
boost pressure (at $n = 2000$ rpm) p_{Sp} _____ 18 bar

For control DA, DG
boost pressure (at $n = 2000$ rpm) p_{Sp} _____ 25 bar

Boost pump:

suction pressure $p_{s, min}$ ($v \leq 30$ mm²/s) _____ ≥ 0.8 bar absolute
at cold start short term ($t < 3$ min) _____ ≥ 0.5 bar absolute

Output

Variable pump:

pressure at port A or B

Nominal pressure p_N _____ 300 bar

Peak pressure p_{max} _____ 350 bar

Boost pump:

peak pressure $p_{sp, max}$ size 18 _____ 25 bar

peak pressure $p_{sp, max}$ size 28, 45, 63 _____ 40 bar

Nominal pressure: Max. design pressure at which fatigue strength is ensured.

Peak pressure: Max. operating pressure which is permissible for short term ($t < 1$ s).

Shaft seal ring

Permissible pressure loading

The service life of the shaft seal ring is affected by the speed of the pump and the case drain pressure. It is recommended that the average, continuous case drain pressure at operating temperature 3 bar absolute not be exceeded (max. permissible case drain pressure 6 bar absolute at reduced speed, see diagram). Short term ($t < 0.1$ s) pressure spikes of up to 10 bar absolute are permitted. The service life of the shaft seal ring decreases with an increase in the frequency of pressure spikes.

The case pressure must be equal to or greater than the external pressure on the shaft seal ring.

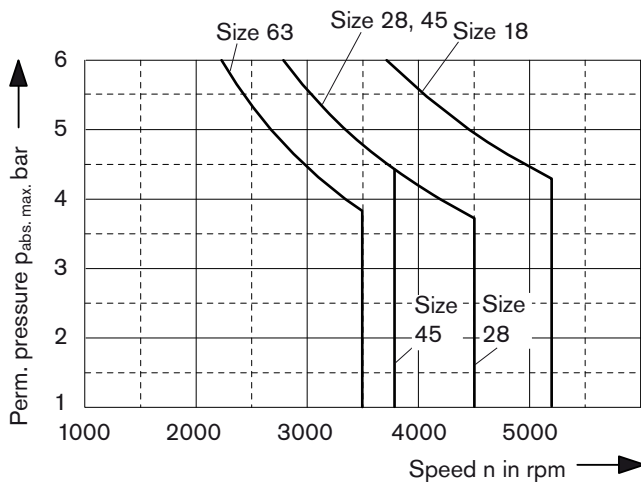

Temperature range

The FKM shaft seal ring is permissible for case temperatures of -25 °C to +115 °C.

Note:

For application cases below -25 °C, an NBR shaft seal ring is necessary (permissible temperature range: -40 °C to +90 °C). Please state NBR shaft seal ring in plain text when ordering. Please contact us.

Technical Data

Table of values (theoretical values, without efficiencies and tolerances; values rounded)

Size			18	28	45	63	
Displacement							
variable pump	$V_{g \max}$	cm ³	18	28	46	63	
boost pump (at p = 20 bar)	$V_{g Sp}$	cm ³	5.5	6.1	8.6	14.9	
Speed							
maximum at $V_{g \max}$	$n_{\max \text{ continuous}}$	rpm	4000	3900	3300	3000	
limited maximum ¹⁾	$n_{\max \text{ limited}}$	rpm	4850	4200	3550	3250	
intermittent maximum ²⁾	$n_{\max \text{ interm.}}$	rpm	5200	4500	3800	3500	
minimum	n_{\min}	rpm	500	500	500	500	
Flow							
at $n_{\max \text{ continuous}}$ and $V_{g \max}$	$q_{v \max}$	l/min	72	109	152	189	
Power ³⁾							
at $n_{\max \text{ continuous}}$ and $V_{g \max}$ $\Delta p = 300 \text{ bar}$	P_{\max}	kW	36	54.6	75.9	94.5	
Torque ³⁾							
at $V_{g \max}$	$\Delta p = 300 \text{ bar}$	T_{\max}	Nm	86	134	220	301
	$\Delta p = 100 \text{ bar}$	T	Nm	28.6	44.6	73.2	100.3
Rotary stiffness							
Shaft end S	c	Nm/rad	20284	32143	53404	78370	
	c	Nm/rad	–	–	73804	92368	
Moment of inertia for rotary group							
	J_{RG}	kgm ²	0.00093	0.0017	0.0033	0.0056	
Angular acceleration, max. ⁴⁾							
	α	rad/s ²	6800	5500	4000	3300	
Filling capacity							
	V	L	0.45	0.64	0.75	1.1	
Mass approx. (without through drive)							
	m	kg	14(18) ⁵⁾	25	27	39	

¹⁾ Restricted maximum speed: – at half corner power (e.g. at $V_{g \max}$ and $p_N / 2$)

²⁾ Intermittent maximum speed: – at high idle speed
 – at overspeed: $\Delta p = 70 \dots 150 \text{ bar}$ and $V_{g \max}$
 – at reversing peaks: $\Delta p < 300 \text{ bar}$ and $t < 0.1 \text{ s}$.

³⁾ Without boost pump

⁴⁾ – The area of validity is situated between the minimum required and maximum permissible speed.

It applies for external stimuli (e.g. engine 2-8 times rotary frequency, cardan shaft twice the rotary frequency).

– The limit value applies for a single pump only.

– The load capacity of the connection parts has to be considered.

⁵⁾ 14kg: MD control, 18kg: HD control

Caution: Exceeding the permissible limit values may result in a loss of function, a reduction in service life or in the destruction of the axial piston unit.

A calculation can be performed to determine the permissible values.

Determining the size

Flow	$q_v = \frac{V_g \cdot n \cdot \eta_v}{1000}$	l/min	V_g = displacement volume per revolution in cm ³
			Δp = differential pressure in bar
			n = speed in rpm
Torque	$T = \frac{V_g \cdot \Delta p}{20 \cdot \pi \cdot \eta_{mh}}$	Nm	η_v = volumetric efficiency
			η_{mh} = mechanical-hydraulic efficiency
Power	$P = \frac{2 \pi \cdot T \cdot n}{60000} = \frac{q_v \cdot \Delta p}{600 \cdot \eta_t}$	kW	η_t = total efficiency

Technical Data

Permissible axial and radial loading on drive shaft

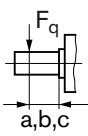
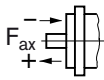
Size			18	28	45	63	
Radial force, max. at distance (from shaft collar)	$F_{q \max}$	N	1300	2500	3600	5000	
	a	mm	16.5	17.5	17.5	17.5	
		$F_{q \max}$	N	1000	2000	2891	4046
	b	mm	29	30	30	30	
Axial force, max.	$F_{q \max}$	N	880	1700	2416	3398	
	c	mm	41.5	42.5	42.5	42.5	
			N	973	987	1500	2200

Note: special requirements apply in the case of belt drives. Please contact us.

Permissible input and through-drive torques

Size			18	28	45	63
Torque (at $V_{g \max}$ and $\Delta p = 300 \text{ bar}$) ¹⁾	T_{\max}	Nm	86	134	220	301
Input torque, max. ²⁾						
at shaft end S	$T_{E \text{ perm.}}$	Nm	192	314	314	602
ANSI B92.1a-1976 (SAE J744)			7/8 in	1 in	1 in	1 1/4 in
at shaft end T	$T_{E \text{ perm.}}$	Nm	–	–	602	970
ANSI B92.1a-1976 (SAE J744)					1 1/4 in	1 3/8 in
Through-drive torque, max.	$T_{D \text{ perm.}}$	Nm	112	220	314	439

¹⁾ Efficiency not considered

²⁾ For drive shafts with no radial force

Torque distribution

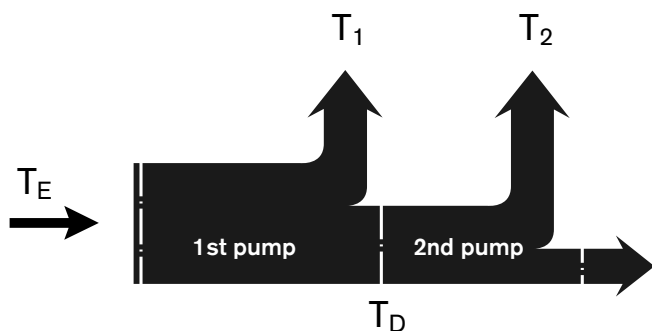

High-Pressure Relief Valves

Setting ranges

High-pressure relief valve, direct operated	Differential pressure setting Δp_{HP}
Setting range for valve 3, 5 Δp 250 - 320 bar (refer to ordering code)	320 bar
	300 bar ¹⁾
	270 bar
Setting range for valve 4, 6 Δp 100 - 250 bar (refer to ordering code)	250 bar
	230 bar
	200 bar ¹⁾
	150 bar
	100 bar

¹⁾ Standard differential pressure setting. The valves will be set to this value if the differential pressure is not specified on ordering.

Please state in plain text when ordering:

(only the Δp_{HP} values shown in the table are possible)

High-pressure relief valve A

Differential pressure setting: $\Delta p_{HD} = \dots$ bar
 opening pressure of the HD valve (at q_{V1}): $p_{max} = \dots$ bar
 ($p_{max} = \Delta p_{HD} + p_{Sp}$)

High-pressure relief valve B

Differential pressure setting: $\Delta p_{HD} = \dots$ bar
 opening pressure of the HD valve (at q_{V1}): $p_{max} = \dots$ bar
 ($p_{max} = \Delta p_{HD} + p_{Sp}$)

Setting diagram

Version without pressure cut-off

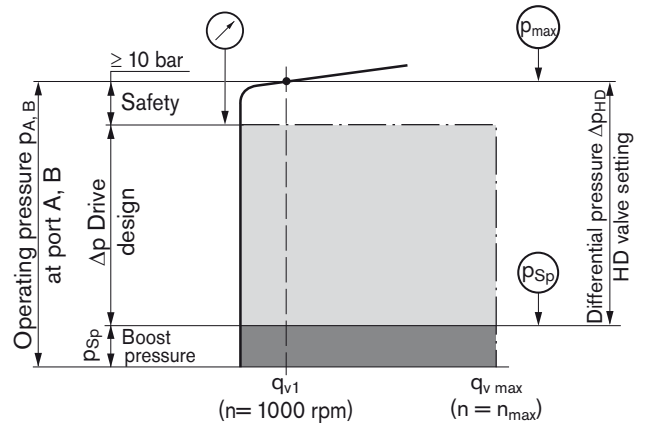

Example: boost pressure 20 bar; operating pressure 290 bar

$$\begin{aligned} \text{Operating pressure } p_{A,B} - \text{boost pressure } p_{Sp} &= \text{differential pressure } \Delta p_{HD} \\ 290 \text{ bar} - 20 \text{ bar} &= 270 \text{ bar} \end{aligned}$$

Version with pressure cut-off

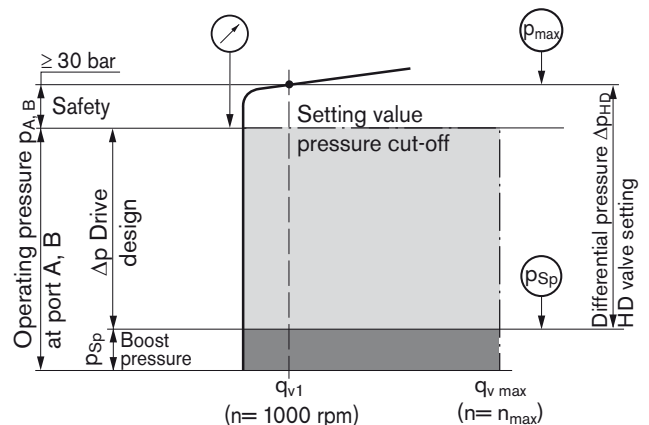

Example: boost pressure 20 bar; operating pressure 290 bar

$$\begin{aligned} \text{Operating pressure } p_{A,B} - \text{boost pressure } p_{Sp} + \text{safety} &= \text{differential pressure } \Delta p_{HD} \\ 290 \text{ bar} - 20 \text{ bar} + 30 \text{ bar} &= 300 \text{ bar} \end{aligned}$$

Note: valve is set at $n = 1000 \text{ rpm}$ and $V_{g \max} (q_{V1})$

Bypass function

The bypass function can only be used for short periods with reduced displacement, e.g. to tow a vehicle out of an immediate danger zone.

Note:

The bypass function is not shown in these circuit diagrams.

Pressure Cut-Off, D

The pressure cut-off corresponds to a pressure regulation which, after reaching the set pressure, adjusts the displacement of the pump to $V_{g \min}$.

This valve prevents the operation of the high-pressure relief valves when accelerating or decelerating.

Both the pressure peaks occurring when the swashplate is swiveled rapidly and also the maximum pressure in the system are safeguarded by the high-pressure relief valves.

The setting range of the pressure cut-off may be anywhere within the entire operating pressure range. However, it must be set 30 bar lower than the setting of the high-pressure relief valves (see setting diagram, page 9).

Please state the setting value of the pressure cut-off in plain text when ordering.

Circuit diagram with pressure cut-off
Hydraulic control, speed related, DA.D3
 Size 28 and 45

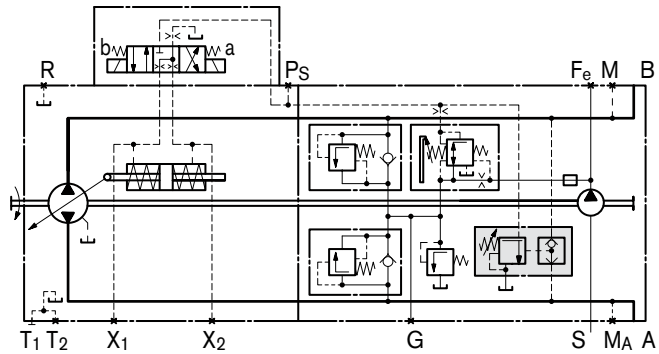

Size 63

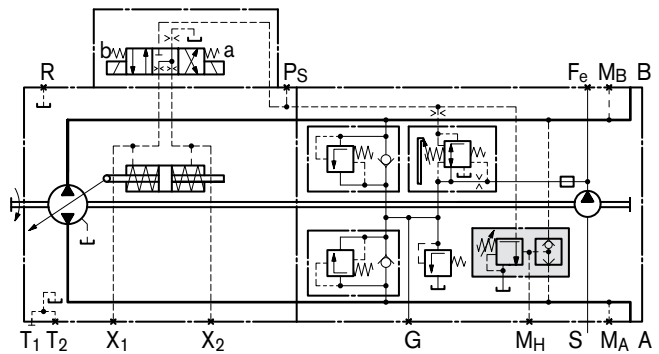

DG - Hydraulic Control, Direct Operated

With the Direct Operated Hydraulic Control (DG), pump displacement is controlled by a hydraulic control pressure applied directly to the stroke cylinder through either the X_1 or X_2 port. In this way, the swashplate and thus the displacement is switchable from $V_g = 0$ to $V_{g \max}$. Each direction of through put flow is assigned to a port.

Pilot pressure 0 bar \triangleq position $V_g = 0$

The required pilot pressure for position $V_{g \max}$ depends on operating pressure and speed.

Max. permissible pilot pressure 40 bar

For project planning, please consult us.

The pressure cut-off and the DA control valve only become effective if the pilot control device used for controlling the DG control is supplied from port P_s .

Assignment of direction of rotation – control – direction of through put flow refer to HD control, page 12 (control pressure X_1 ; X_2).

Standard version

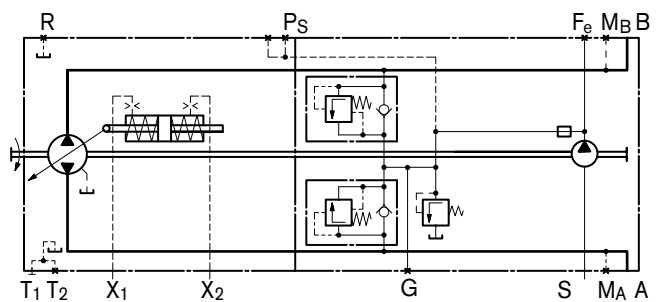

Version with DA control valve and pressure cut-off

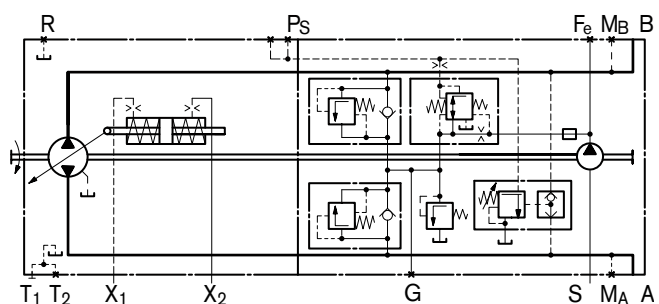

MD - Mechanical Pivot Control (Size 18 only)

The swashplate is adjusted directly and thus the displacement of the pump is continuously varied depending on the position of the pivot. A swivel direction of the pivot is assigned to each flow direction.

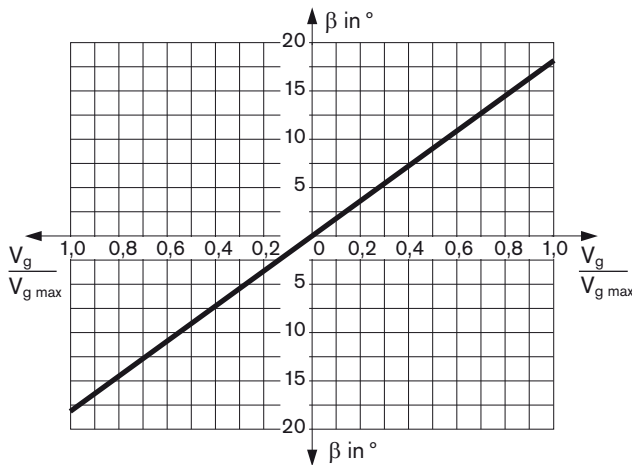

Swivel angle β at the control lever for deflection:

Start of control at $\beta = 0^\circ$

End of control at $\beta = 17.79^\circ$ (max. displacement $V_{g\ max}$)

The required actuating torque is independent of the operating pressure, speed, displacement, design of the control plate and its torsion.

- Higher operating pressure → higher actuating torque
- Higher speed → higher actuating torque
- Larger displacement → lower actuating torque

Standard version (MD)

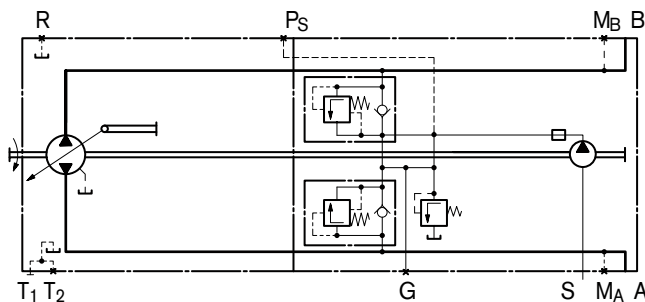

Variation: Spring neutral position centering (MDN)

Spring neutral position centering automatically sets the pump to swivel angle 0 as soon as there is no actuating torque at the pivot pin.

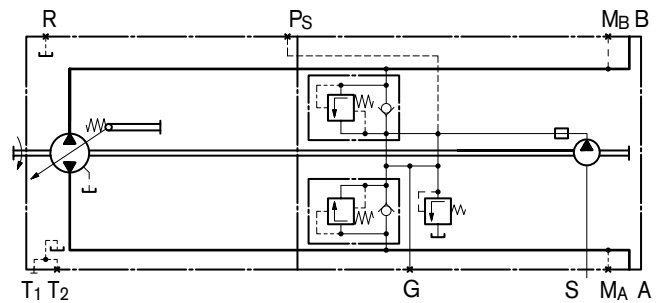

Assignment

Direction of rotation - Control - Direction of through put flow

	Lever direction	Through put flow	Operating pressure
Direction of rotation CW	a	B to A	M_A
	b	A to B	M_B
Direction of rotation CCW	a	A to B	M_B
	b	B to A	M_A

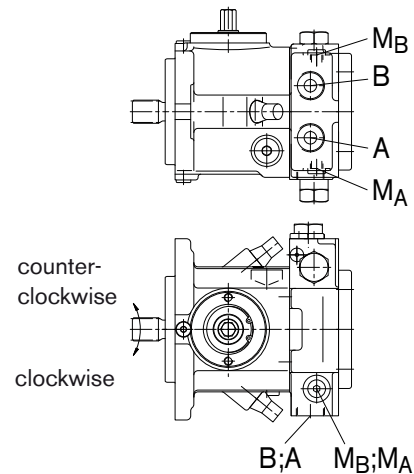

HD - Hydraulic Control, Pilot-Pressure Related

Depending on the pressure difference of the pilot pressure p_{St} in the two control lines (ports Y_1 and Y_2), the stroke cylinder of the pump is supplied with control pressure via the HD control unit. Thus, the swashplate – and, therefore, the displacement – to be infinitely adjustable. A different through put flow direction is associated with each control line.

If the pump is also equipped with a DA control valve (see page 15), automotive operation is possible for travel drives.

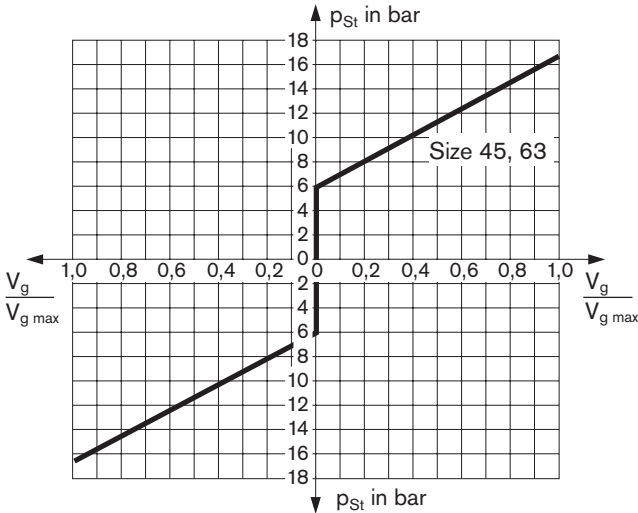

Size	18	28	45	63
Start of control (V_{g0}) p_{St} bar	6	6	6	6
End of control (V_{gmax}) p_{St} bar	15.7	16	16.7	16.7

p_{St} : pilot pressure at port Y_1, Y_2

Please note:

The external control device must vent the Y_1 and Y_2 ports to tank pressure in neutral.

Note

The spring return feature in the control unit is not a safety device

The spool valve inside the control unit can get stuck in an undefined position by internal contamination (contaminated hydraulic fluid, abrasion or residual contamination from system components). As a result, the axial piston unit can no longer supply the flow specified by the operator.

Check whether your application requires that remedial measures be taken on your machine in order to bring the driven consumer into a safe position (e.g. immediate stop).

Assignment

Direction of rotation - Control - Direction of through put flow

	Pilot pressure	Control pressure	Through put flow	Operating pressure
Direction of rotation cw	Y_1	X_1	A to B	M_B
	Y_2	X_2	B to A	M_A
Direction of rotation ccw	Y_1	X_1	B to A	M_A
	Y_2	X_2	A to B	M_B

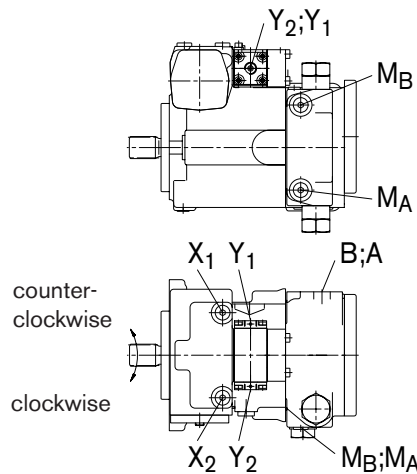

Standard version

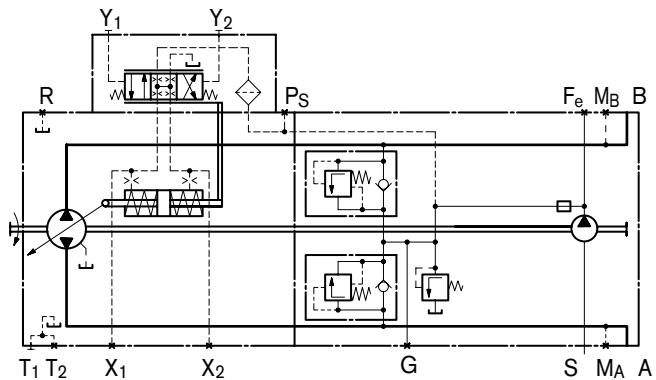

Version with DA control valve and pressure cut-off

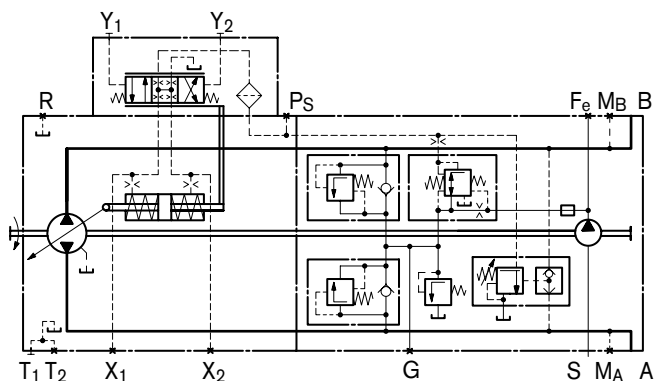

HW - Hydraulic Control, Mechanical Servo

Depending on the actuation direction a or b of the control lever, the stroke cylinder of the pump is supplied with control pressure via the HW control unit. Thus, the swashplate – and, therefore, the displacement – to be infinitely adjustable. A different through put flow direction is associated with each direction of control lever actuation.

If the pump is also equipped with a DA control valve (see page 15), automotive operation is possible for travel drives.

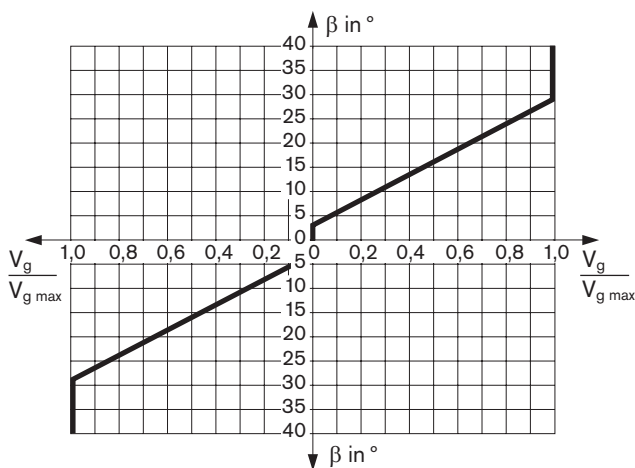

Swivel angle β at the control lever for deflection:

Start of control at $\beta = 3^\circ$

End of control at $\beta = 29^\circ$ (max. displacement $V_{g, max}$)

Mech. stop: $\pm 40^\circ$

The maximum required torque at the lever is 170 Ncm. To prevent damage to the HW control module a positive mechanical stop must be provided for the HW control linkage.

Note:

Spring centering enables the pump to move automatically into neutral position ($V_g = 0$) as soon as there is no longer any torque on the control lever of the HW control unit (regardless of deflection angle).

Variation: Neutral position switch, L

The switch contact in the neutral position switch is closed when the control lever on the HW control unit is in its neutral position. The switch opens if the control lever is moved out of neutral in either direction.

The neutral position switch provides a safety function for drive units that require zero flow under certain operating conditions (e.g. starting engine).

Technical data of neutral position switch	
Load capacity	20 A (continuous), without switching operating
Switching capacity	15 A / 32 V (ohm's load) 4 A / 32 V (inductive load)
Connector version	DEUTSCH connector DT04-2P-EP04 (mating connector see page 39)

Assignment
Direction of rotation - Control - Direction of through put flow

	Lever direction	Control pressure	Through put flow	Operating pressure
Direction of rotation CW	a	X_2	B to A	M_A
	b	X_1	A to B	M_B
Direction of rotation CCW	a	X_2	A to B	M_B
	b	X_1	B to A	M_A

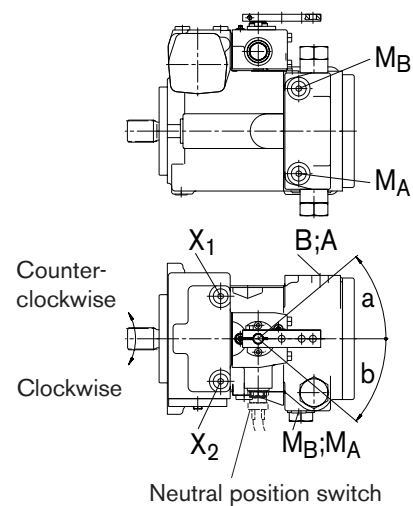

Standard version

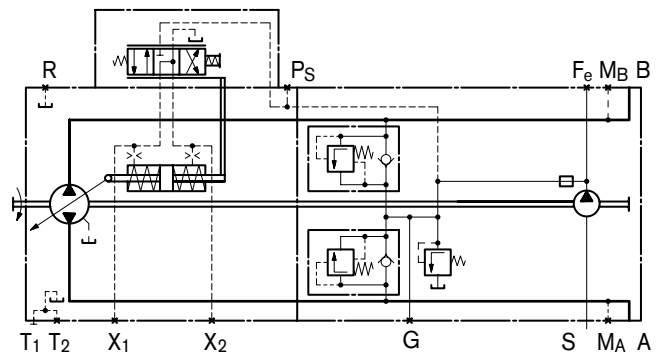

Version with DA control valve, neutral position switch and pressure cut-off

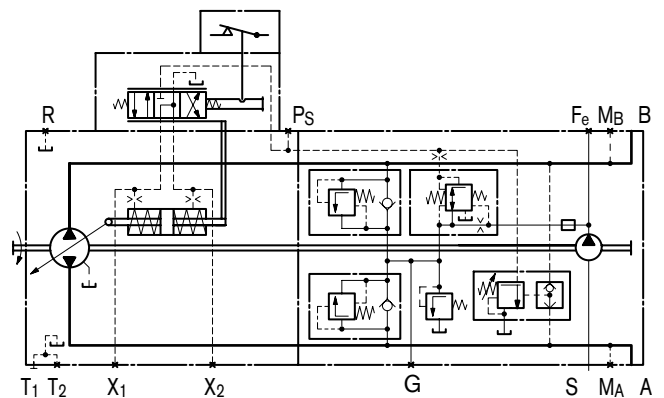

DA - Hydraulic Control, Speed Related

The DA control is an engine speed-dependent, or automotive, type control system. The built-in DA regulating cartridge generates a pilot pressure that is proportional to pump (engine) drive speed. This pilot pressure is directed to the positioning cylinder of the pump by a solenoid actuated 4/3 way directional valve. Pump displacement is infinitely variable in each direction of flow, and is influenced by both pump drive speed and discharge pressure. Flow direction (i.e. machine forward or reverse) is controlled by energizing solenoid a or b.

Increasing pump drive speed generates a higher pilot pressure from the DA cartridge, with a subsequent increase in pump flow and/or pressure.

Dependent on the selected pump operating characteristics, increasing system pressure (i.e. machine load) causes the pump to swivel back towards a smaller displacement. Engine overload (anti-stall) protection is achieved by the combination of this pressure-related pump de-stroking, and the reduction of pilot pressure as the engine speed drops.

Any additional power requirement, such as implement hydraulics, may result in further engine pull down. This causes a further reduction in pilot pressure and therefore pump displacement. Automatic power division and full utilization of available power is thus achieved for both the vehicle transmission and the implement hydraulics, with priority given to the implement hydraulics.

To provide controllable reduced vehicle speed operation when high engine speeds are required for fast implement hydraulics, various inching options are available.

The DA regulating cartridge can also be used in pumps with conventional control devices, such as EP, HW or HD, to provide an engine anti-stall function, or as a combination of automotive and displacement control functions.

Application of the DA control is only appropriate on certain types of vehicle drive systems, and requires a review of the engine and vehicle parameters to ensure proper application of the pump, and safe and efficient machine operation. All DA applications must therefore be reviewed by a Rexroth Application Engineer.

Solenoid technical data	DA1	DA2
Voltage	12 V DC (±20 %)	24 V DC (±20 %)
Neutral position V_{g0}	de-energized	de-energized
Position V_{gmax}	current energized	current energized
<hr/>		
Nominal resistance (at 20 °C)	5.5 Ω	21.7 Ω
Nominal power	26.2 W	26.5 W
Current required, minimum effective	1.32 A	0.67 A
Actuated time	100 %	100 %
Type of protection	see range of connectors on page 39	

Standard: switching solenoid without manual emergency operation.
 On request: manual emergency operation with spring reset available.

Direction of rotation - Control - Direction of through put flow				
	Actuation of solenoid	Control pressure	Through put flow	Operating pressure
Direction of rotation CW	a	X_2	B to A	M_A
	b	X_1	A to B	M_B
Direction of rotation CCW	a	X_2	A to B	M_B
	b	X_1	B to A	M_A

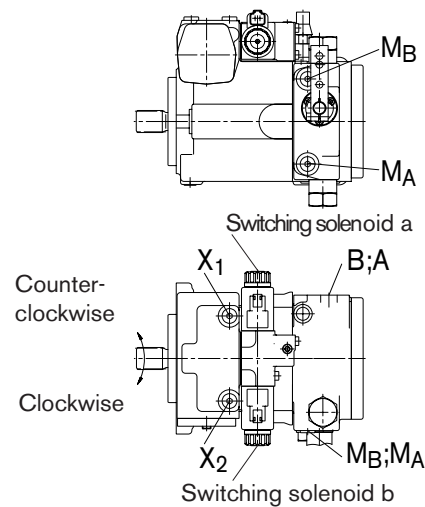

Hydraulic control, speed related, DA control valve, fixed setting, DA1D2/DA2D2

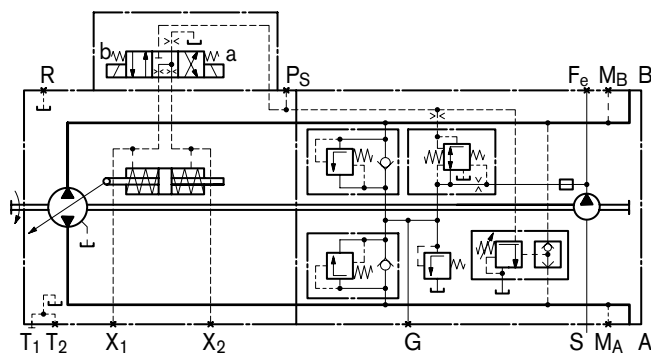

DA - Hydraulic Control, Speed Related

Function and control of DA control Valves

DA control valve, fixed setting (2)

Pilot pressure is generated in relation to drive speed. When ordering, please state in plain text: Start of control (set at factory).

DA control valve, mechanically adjustable with position lever, (3)

Pilot pressure is generated in relation to drive speed. When ordering, please state in plain text: Start of control (set at factory).

Pilot pressure may be reduced, independently of drive speed, through mechanical operation of the position lever (inch function).

Max. perm. operating torque at the position lever $T_{max} = 4 \text{ Nm}$

Max. angle of rotation 70° , lever position: any.

Variation 3R ___ actuating direction of the position lever
- clockwise

Variation 3L ___ actuating direction of the position lever
- counterclockwise

DA control valve, fixed setting and hydraulic inch valve mounted, (4, 8)

(only for pumps with DA control unit)

Permits the pilot pressure to be reduced independently of the drive speed via hydraulic control (port Z).

Variation 4:

Control at port Z by means of brake fluid according to ISO 4925 (no mineral oil) from the vehicle braking system (hydraulically linked with the service brake).

Variation 8:

Control at port Z by means of brake fluid based on mineral oil.

DA control valve with fixed setting, ports for pilot control device as inch valve (7)

Any reduction of pilot pressure, independent from the drive speed through the mechanical operation of the pilot control device.

The pilot control device is installed separately from the pump (for example in the driver's cabin) and connected with the pump by 2 hydraulic control lines via ports P_S and Y.

A suitable pilot control device must be ordered separately and is not included in supply.

Detailed information is available from our sales department and on our website www.boschrexroth.com/da-control. Use our computer program to work out the input design that meets your needs. A DA control must be approved by Rexroth.

Note: see page 40 for rotary inch valves.

Circuit diagrams:

DA1D3/DA2D3

Hydraulic control, speed related, DA control valve, mech. adjustable with position lever

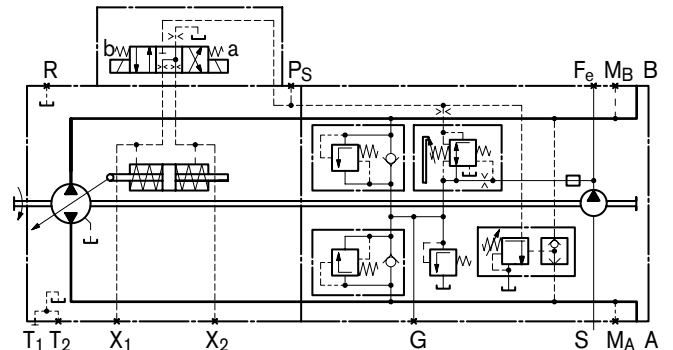

DA1D4/DA2D4

Hydraulic control, speed related, DA control valve, fixed setting, with hydraulic inch valve

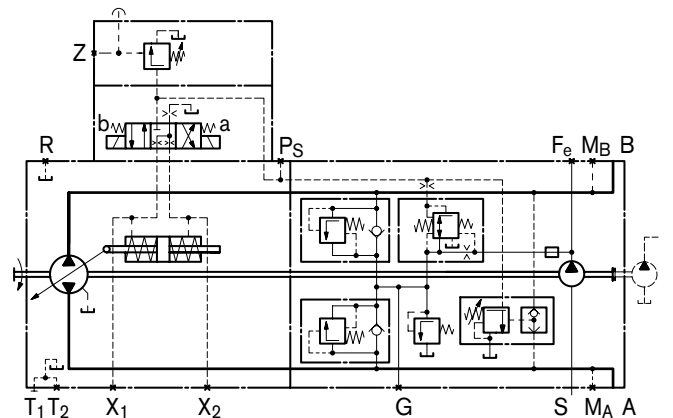

DA1D7/DA2D7

Hydraulic control, speed related, DA control valve, fixed setting, with separately installed pilot control device as inch valve

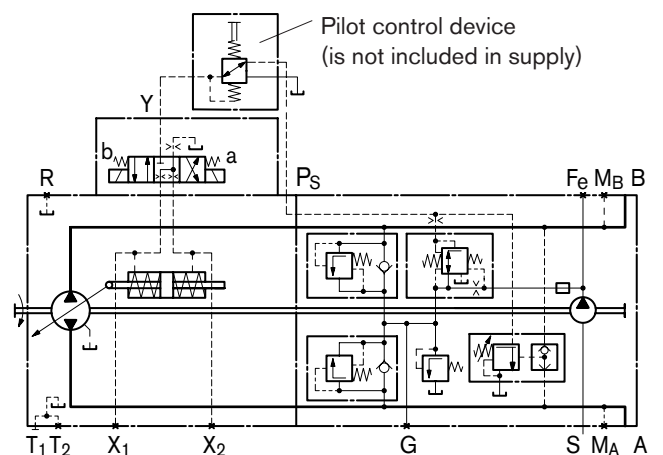

EP - Electric Control, With Proportional Solenoid

Depending on the preselected current I at the two proportional solenoids (a and b), the stroke cylinder of the pump is supplied with control pressure via the EP control unit. Thus, the swashplate – and, therefore, the displacement – to be infinitely adjustable. One direction of through put flow is assigned to each proportional solenoid.

If the pump is also equipped with a DA control valve (see page 15), automotive operation is possible for travel drives.

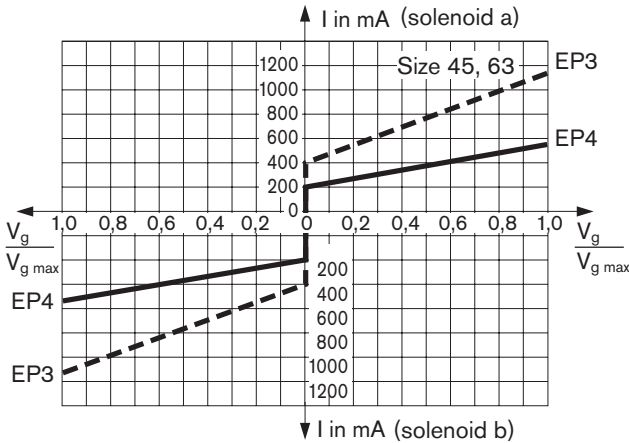

Control current					
EP3	Size	18	28	45	63
Start of control	mA	400	400	400	400
End of control	mA	1050	1060	1115	1115
EP4	Size	18	28	45	63
Start of control	mA	200	200	200	200
End of control	mA	525	530	560	560

Solenoid technical data	EP3	EP4
Voltage	12 V DC ($\pm 20\%$)	24 V DC ($\pm 20\%$)
Limiting current	1.54 A	0.77 A
Nominal resistance (at 20 °C)	5.5 Ω	22.7 Ω
Dither frequency	100 Hz	100 Hz
Actuated time	100 %	100 %
Type of protection	see range of connectors on page 39	

The following electronic controllers and amplifiers are available for actuating the proportional solenoids (details also available at www.boschrexroth.com/mobile-electronics):

- BODAS controller RC
 - series 20 _____ RE 95200
 - series 21 _____ RE 95201
 - series 22 _____ RE 95202
 - series 30 _____ RE 95203
 and application software
- Analog amplifier RA _____ RE 95230

Note

The spring return feature in the control unit is not a safety device

The spool valve inside the control unit can get stuck in an undefined position by internal contamination (contaminated hydraulic fluid, abrasion or residual contamination from system components). As a result, the axial piston unit can no longer supply the flow specified by the operator.

Check whether your application requires that remedial measures be taken on your machine in order to bring the driven consumer into a safe position (e.g. immediate stop).

Assignment				
Direction of rotation - Control - Direction of through put flow				
	Actuation of solenoid	Control pressure	Through put flow	Operating pressure
Direction of rotation CW	a	X ₁	A to B	M _B
	b	X ₂	B to A	M _A
Direction of rotation CCW	a	X ₁	B to A	M _A
	b	X ₂	A to B	M _B

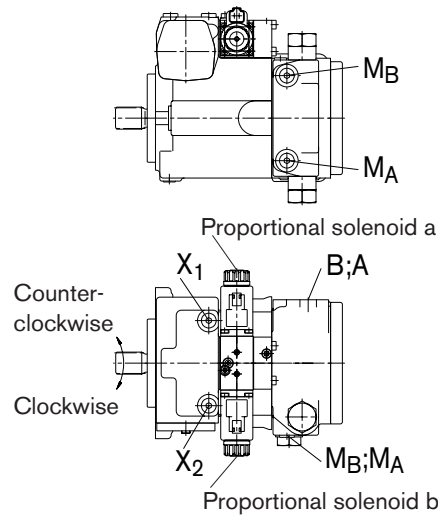

Standard: proportional solenoid without manual emergency operation.
 On request: manual emergency operation with spring reset available.

EP - Electric Control, With Proportional Solenoid

Standard version

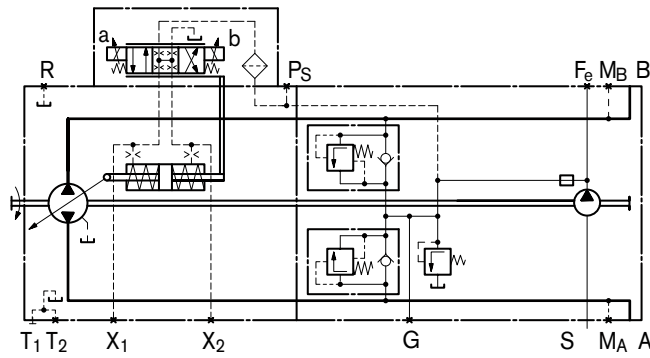

Version with DA control valve and pressure cut-off

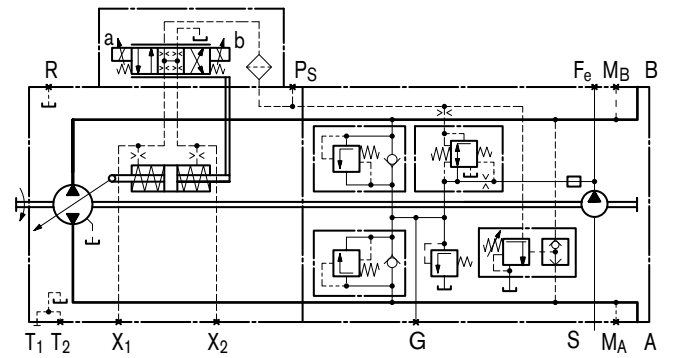

EZ - Electric Two-Position Control, With Switching Solenoid

By energizing or de-energizing a control current to either switching solenoid a or b, the stroke cylinders of the pump are supplied with control pressure by the EZ control unit. In this way, the swashplate and thus the displacement is switchable without intermediate settings from $V_g = 0$ to $V_{g,max}$. Each direction of through put flow is assigned to a switching solenoid.

Solenoid technical data	EZ1	EZ2
Voltage	12 V DC ($\pm 20\%$)	24 V DC ($\pm 20\%$)
Neutral position $V_g = 0$	de-energized	de-energized
Position $V_{g,max}$	current energized	current energized
Nominal resistance (at 20 °C)	5.5 Ω	21.7 Ω
Nominal power	26.2 W	26.5 W
Current required, minimum effective	1.32 A	0.67 A
Actuated time	100 %	100 %
Type of protection	see range of connectors on page 39	

Standard: switching solenoid without manual emergency operation.
On request: manual emergency operation with spring reset available.

Assignment direction of rotation - Control - Direction of through put flow DA control see page 14.

Standard version

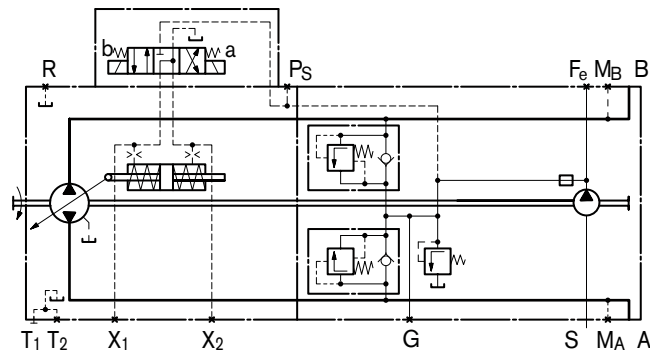

Unit Dimensions, Size 18

Before finalizing your design, please request a binding installation drawing. Dimensions in mm.

Hydraulic control, direct operated, DG

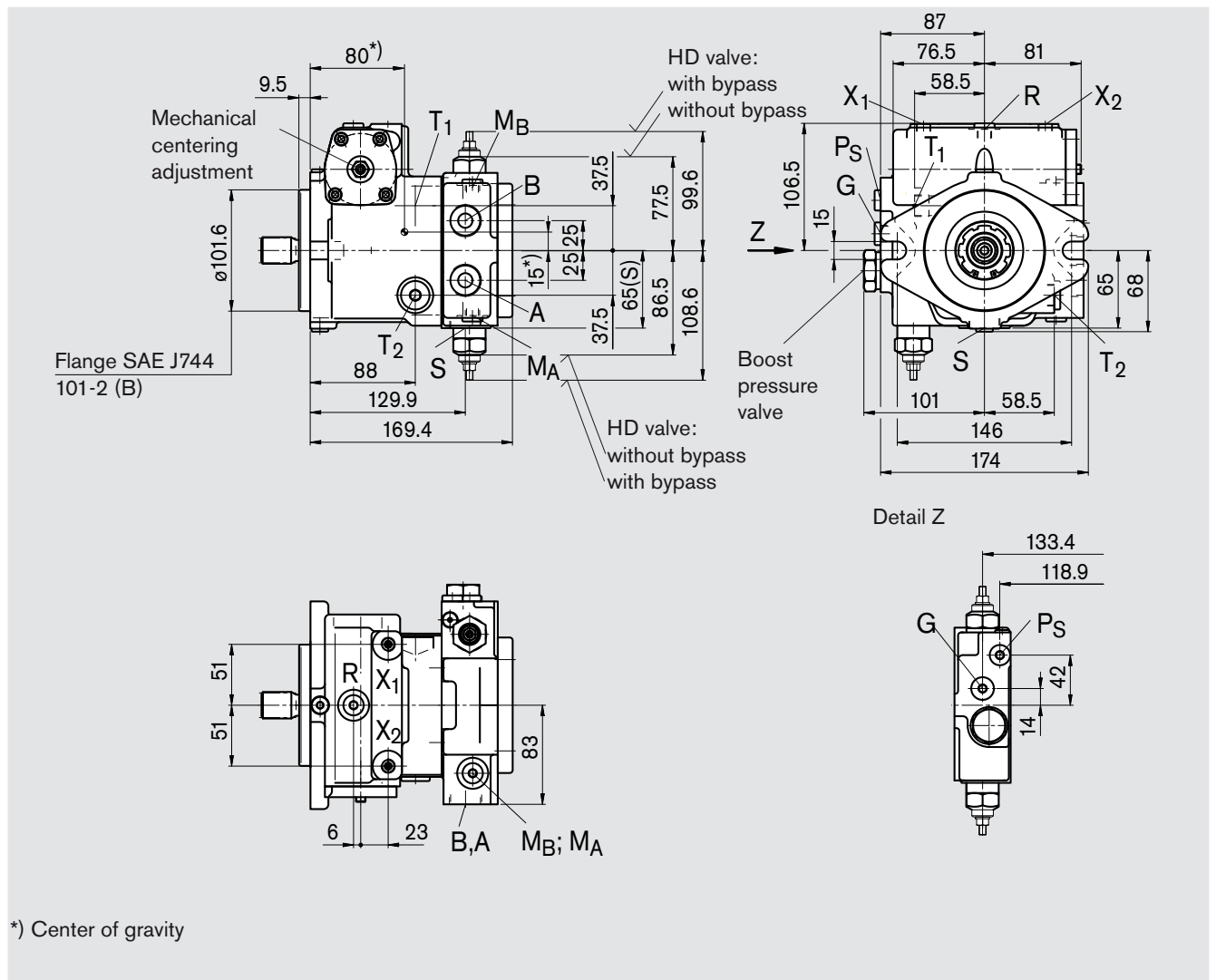

Unit Dimensions, Size 18

Before finalizing your design, please request a binding installation drawing. Dimensions in mm.

Shaft end

S Splined shaft 7/8in
13T 16/32DP ¹⁾
(SAE J744 – 22-4 (B))

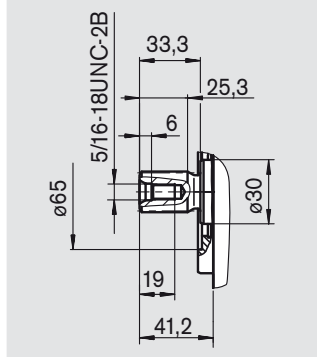

Ports

A, B	service line ports	DIN 3852	M27x2; 16 deep	330 Nm ²⁾
T ₁	case drain or fill	DIN 3852	M18x1.5; 12 deep	140 Nm ²⁾
T ₂	case drain ³⁾	DIN 3852	M18x1.5; 12 deep	140 Nm ²⁾
M _A , M _B	pressure gauge - operating pressure A, B ³⁾	DIN 3852	M12x1.5; 12 deep	50 Nm ²⁾
R	air bleed ³⁾	DIN 3852	M12x1.5; 12 deep	50 Nm ²⁾
S	boost suction port	DIN 3852	M26x1.5; 16 deep	230 Nm ²⁾
X ₁ , X ₂	ports for control pressure (before orifice) ³⁾	DIN 3852	M12x1.5; 12 deep	50 Nm ²⁾
G	pressure port for auxiliary circuit ³⁾	DIN 3852	M14x1.5; 12 deep	80 Nm ²⁾
P _S	control pressure supply ³⁾	DIN 3852	M12x1.5; 12 deep	50 Nm ²⁾
Y ₁ , Y ₂	remote control ports (only HD)	DIN 3852	M14x1.5; 12 deep	80 Nm ²⁾

¹⁾ ANSI B92.1a-1976, 30° pressure angle, flat root, side fit, tolerance class 5

²⁾ Please observe the general notes for the max. tightening torques on page 44

³⁾ Plugged

Unit Dimensions, Size 18

Before finalizing your design, please request a binding installation drawing. Dimensions in mm.

Hydraulic control, pilot-pressure related, HD

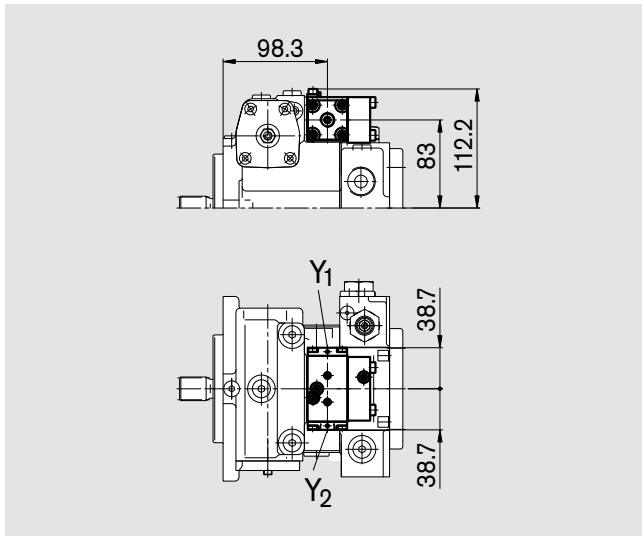

Hydraulic control, mechanical servo, HW

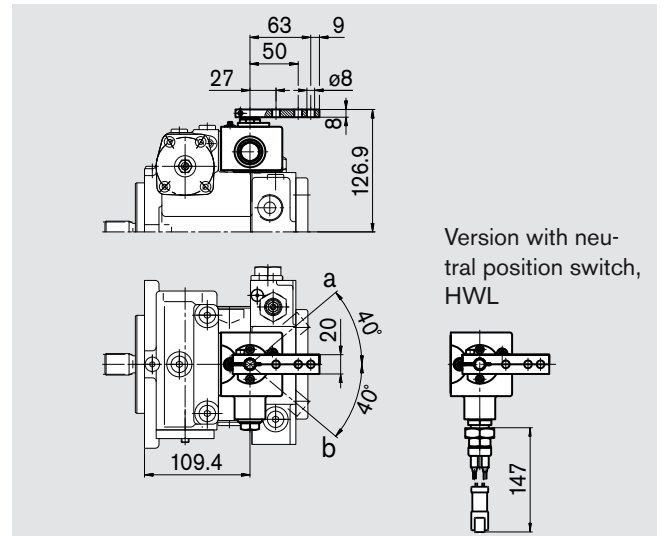

Electric two-position control with switching solenoid, EZ

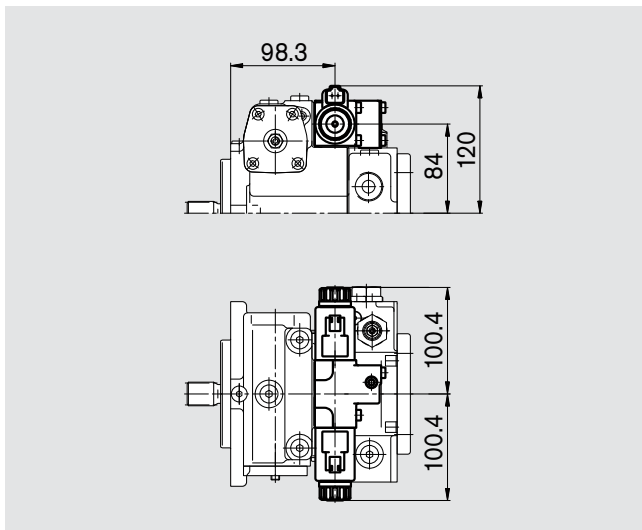

Electric control with proportional solenoid, EP

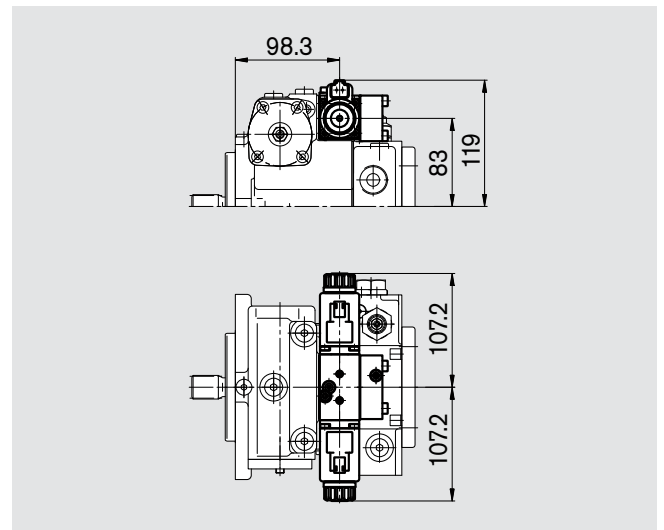

Mechanical pivot control, MD

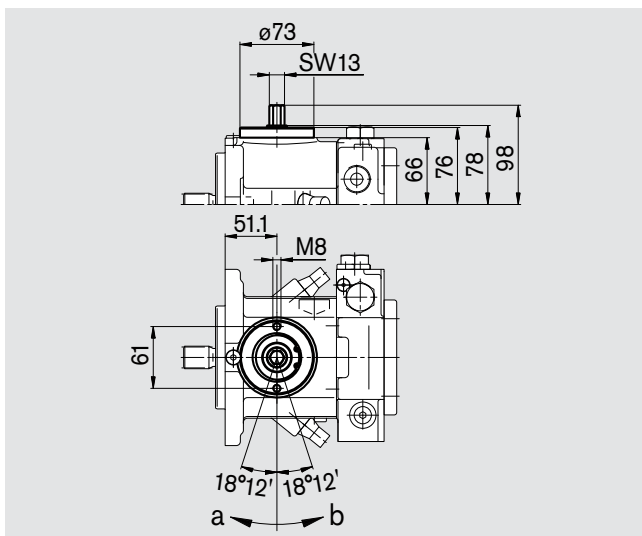

Mechanical pivot control, spring neutral position centering, MDN

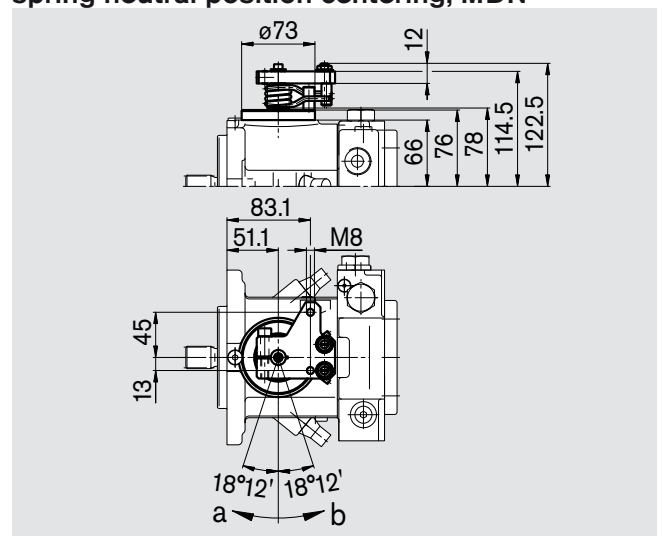

Unit Dimensions, Size 28

Hydraulic control, direct operated, DG

Before finalizing your design, please request a binding installation drawing. Dimensions in mm.

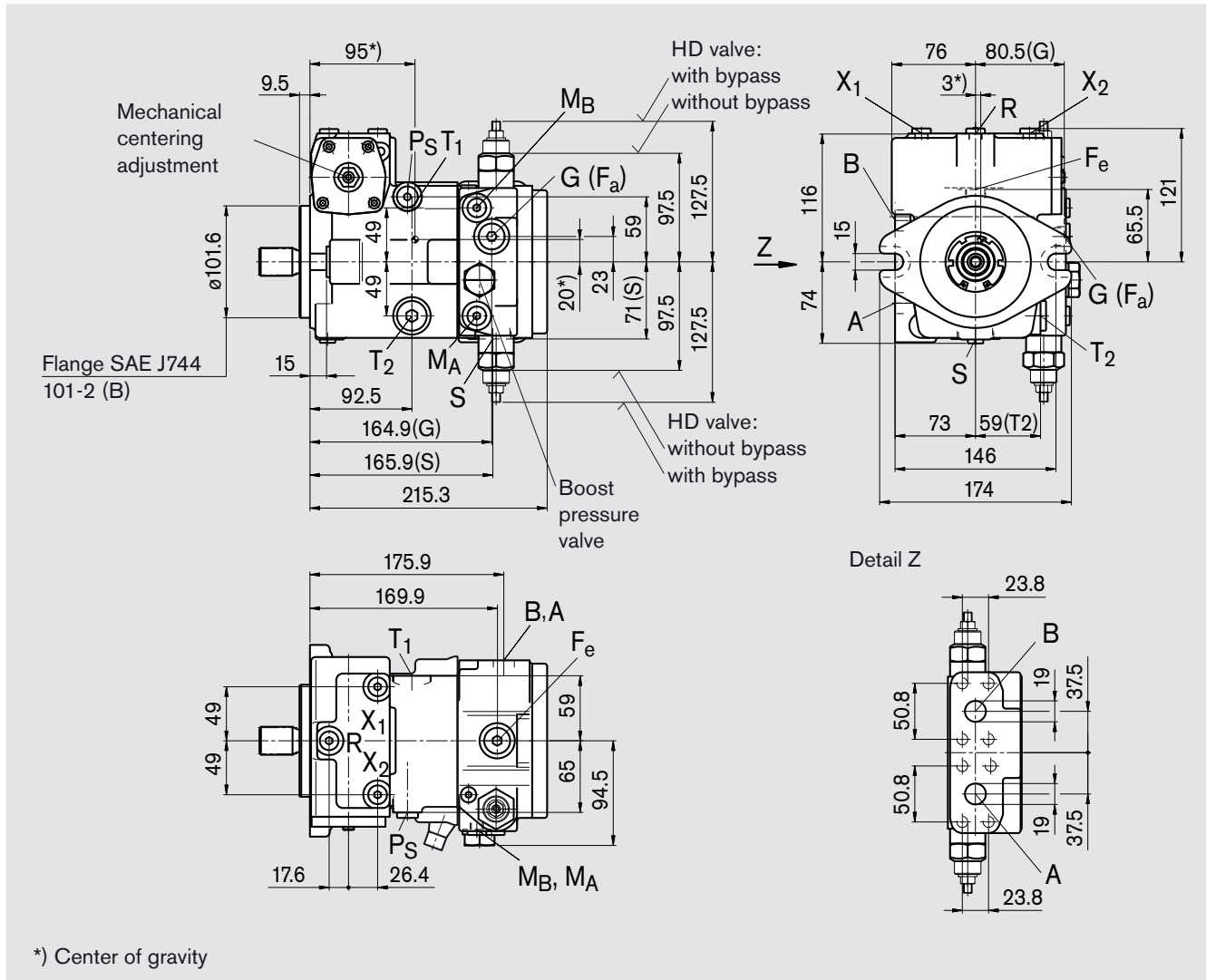

*) Center of gravity

Unit Dimensions, Size 28

Before finalizing your design, please request a binding installation drawing. Dimensions in mm.

Shaft end

S Splined shaft 1 in
15T 16/32DP ¹⁾
(SAE J744 – 25-4 (B-B))

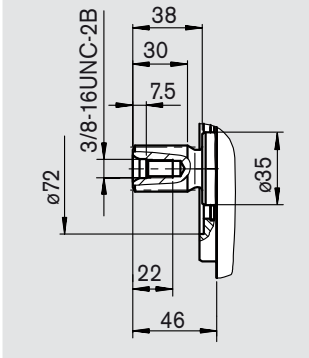

Ports

A, B	service line ports (high-pressure series) fixing thread A/B	SAE J518 DIN 13	3/4 in M10x1.5; 17 deep ²⁾
T ₁	case drain or fill	DIN 3852	M22x1.5; 14 deep 210 Nm ²⁾
T ₂	case drain ³⁾	DIN 3852	M22x1.5; 14 deep 210 Nm ²⁾
M _A , M _B	pressure gauge - operating pressure A, B ³⁾	DIN 3852	M12x1.5; 12 deep 50 Nm ²⁾
R	air bleed ³⁾	DIN 3852	M12x1.5; 12 deep 50 Nm ²⁾
S	boost suction port	DIN 3852	M33x2; 18 deep 540 Nm ²⁾
X ₁ , X ₂	ports for control pressure (before orifice) ³⁾	DIN 3852	M12x1.5; 12 deep 50 Nm ²⁾
G (F _a)	pressure port for auxiliary circuits ³⁾ (without control cartridge)	DIN 3852	M18x1.5; 12 deep 140 Nm ²⁾
P _S	control pressure supply, boost pressure ³⁾	DIN 3852	M14x1.5; 12 deep 80 Nm ²⁾
F _e	filter input ³⁾	DIN 3852	M18x1.5; 12 deep 140 Nm ²⁾
Y ₁ , Y ₂	remote control ports (only HD)	DIN 3852	M14x1.5; 12 deep 80 Nm ²⁾
Z	pilot pressure port (only DA4/8) ³⁾	DIN 3852	M10x1; 8 deep 30 Nm ²⁾
Y	pilot pressure port (only DA7)	DIN 3852	M14x1.5; 12 deep 80 Nm ²⁾

¹⁾ ANSI B92.1a-1976, 30° pressure angle, flat root, side fit, tolerance class 5

²⁾ Please observe the general notes for the max. tightening torques on page 44

³⁾ Plugged

Unit Dimensions, Size 28

Before finalizing your design, please request a binding installation drawing. Dimensions in mm.

Hydraulic control, pilot-pressure related, HD

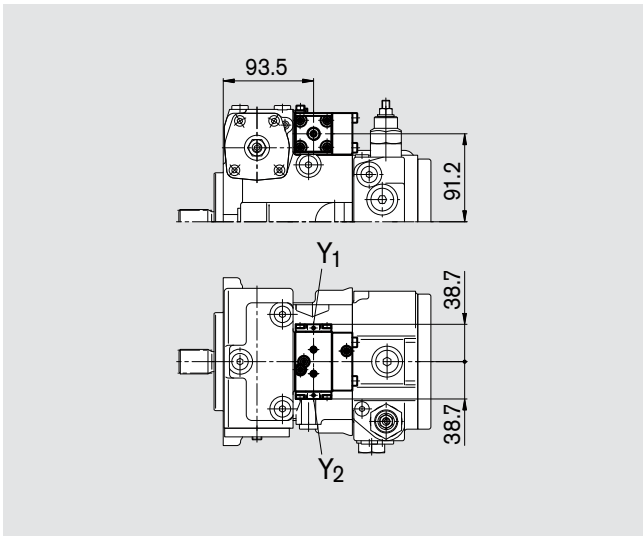

Hydraulic control, mechanical servo, HW

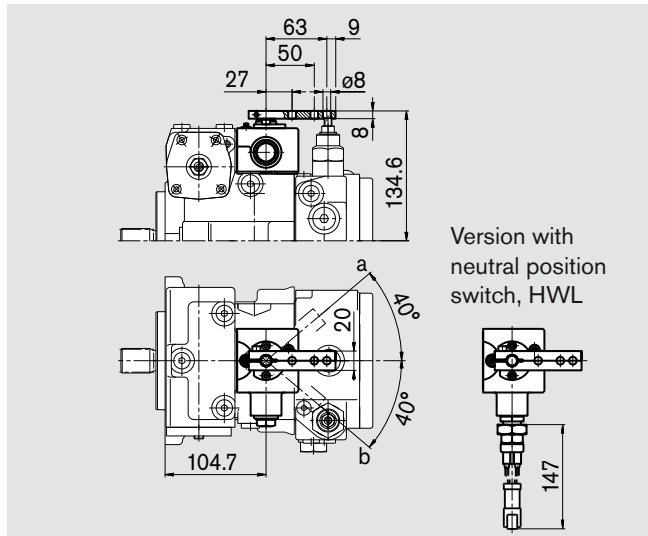

Electric two-position control with switching solenoid, EZ

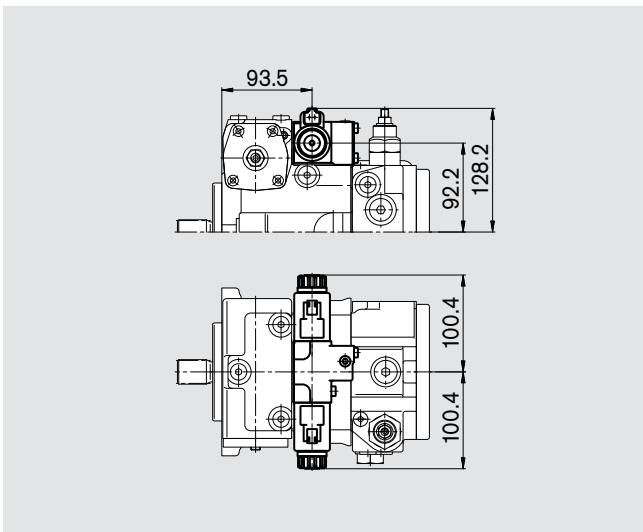

Electric control with proportional solenoid, EP

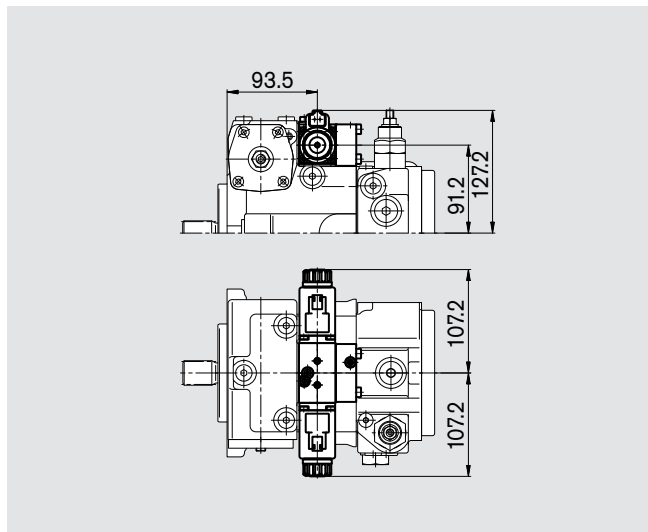

Pressure cut-off, D

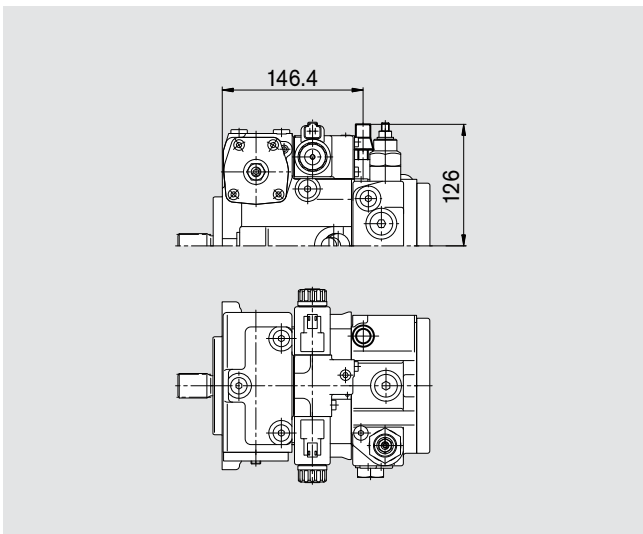

Unit Dimensions, Size 28

Before finalizing your design, please request a binding installation drawing. Dimensions in mm.

Hydraulic control, speed related, DA

Control valve, fixed setting, DA2

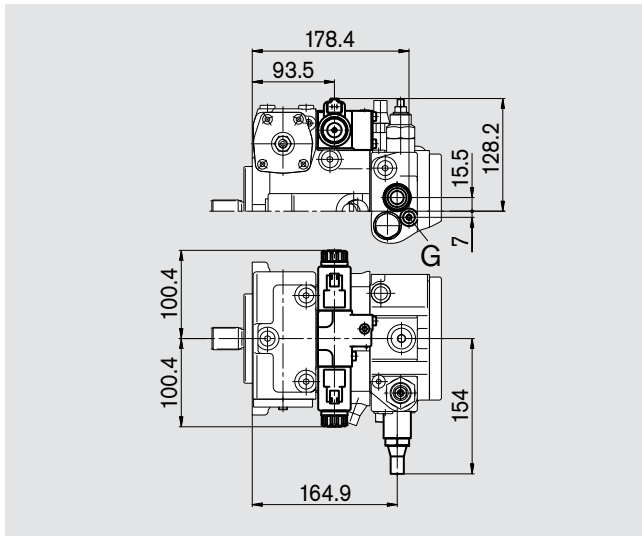

Control valve, fixed setting and hydraulic inch valve mounted, DA4/DA8

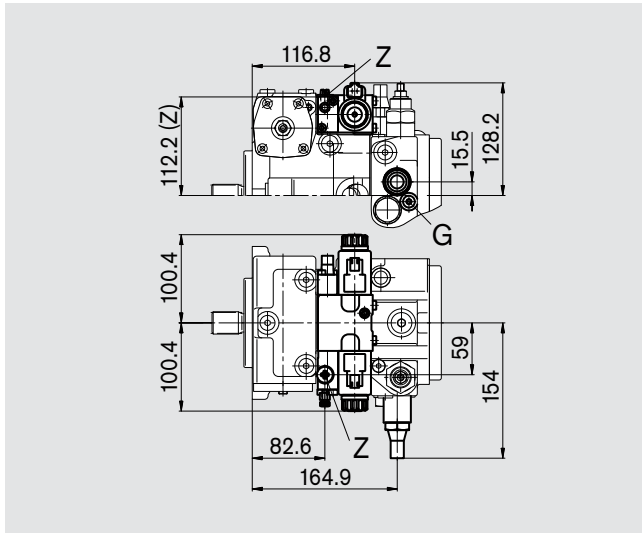

Control valve, mech. adjustable with position lever, DA3

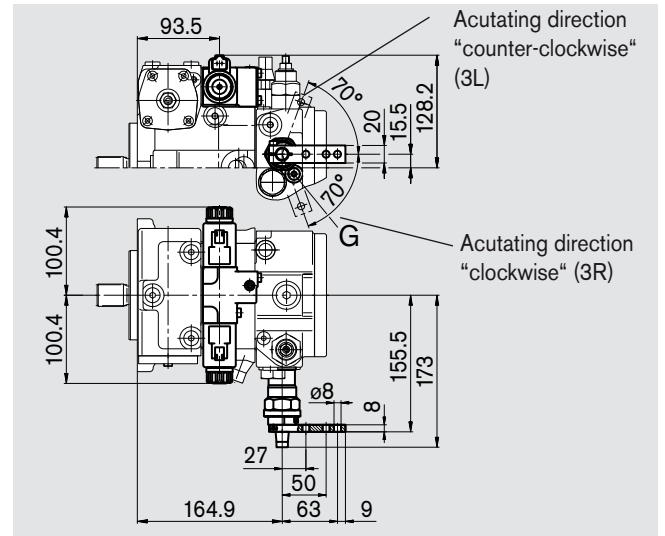

Control valve, fixed setting and ports for pilot control device DA7

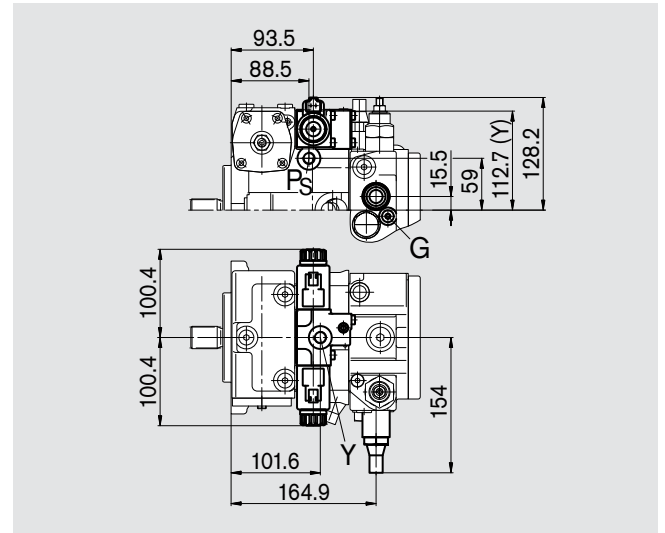

Important:

Position and size of port G on version with DA control valve

G DIN 3852 M10x1; 8 deep 30 Nm ¹⁾

¹⁾ Please observe the general notes for the max. tightening torques on page 44

Unit Dimensions, Size 45

Before finalizing your design, please request a binding installation drawing. Dimensions in mm.

Hydraulic control, direct operated, DG

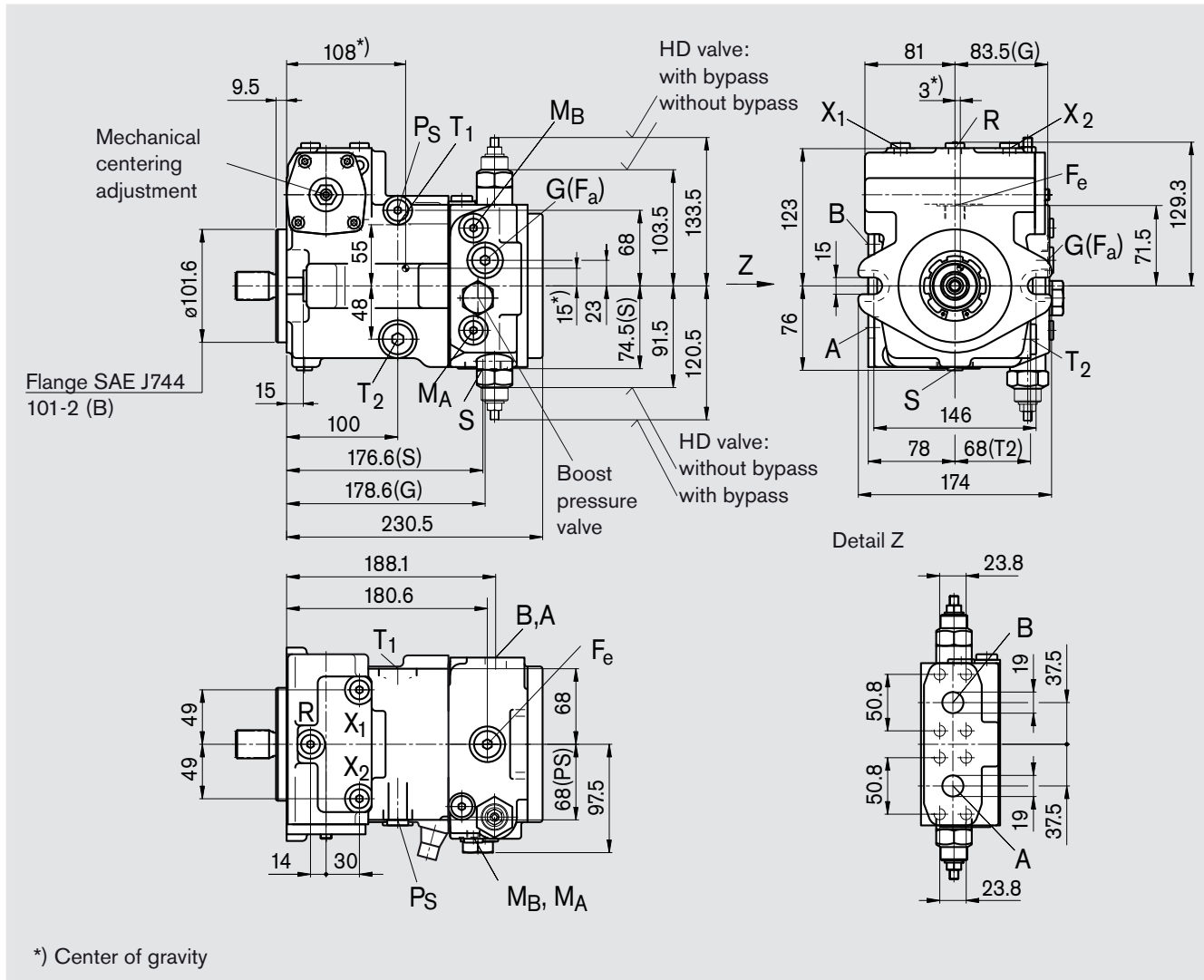

Unit Dimensions, Size 45

Before finalizing your design, please request a binding installation drawing. Dimensions in mm.

Shaft ends

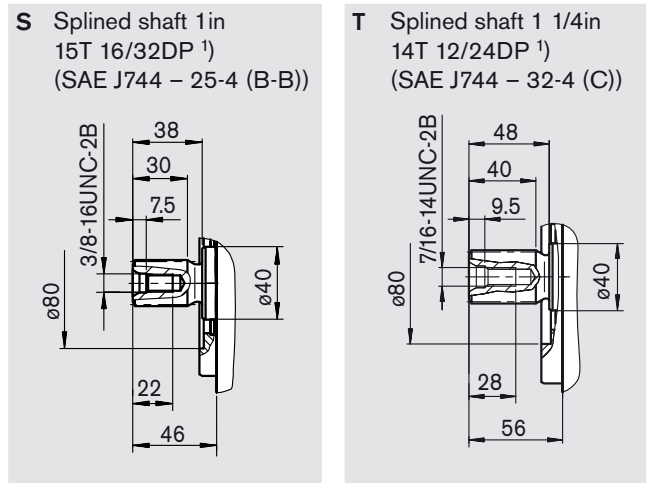

Ports

A, B	service line ports (high-pressure series) fixing thread A/B	SAE J518	3/4 in	
		DIN 13	M10x1.5; 17 deep ²⁾	
T ₁	case drain or fill	DIN 3852	M22x1.5; 14 deep	210 Nm ²⁾
T ₂	case drain ³⁾	DIN 3852	M22x1.5; 14 deep	210 Nm ²⁾
M _A , M _B	pressure gauge - operating pressure A, B ³⁾	DIN 3852	M12x1.5; 12 deep	50 Nm ²⁾
R	air bleed ³⁾	DIN 3852	M12x1.5; 12 deep	50 Nm ²⁾
S	boost suction port	DIN 3852	M33x2; 18 deep	540 Nm ²⁾
X ₁ , X ₂	ports for control pressure (before orifice) ³⁾	DIN 3852	M12x1.5; 12 deep	50 Nm ²⁾
G (F _a)	pressure port for auxiliary circuits ³⁾	DIN 3852	M18x1.5; 12 deep	140 Nm ²⁾
P _S	control pressure supply, boost pressure ³⁾	DIN 3852	M14x1.5; 12 deep	80 Nm ²⁾
F _e	filter input ³⁾	DIN 3852	M18x1.5; 12 deep	140 Nm ²⁾
Y ₁ , Y ₂	remote control ports (only HD)	DIN 3852	M14x1.5; 12 deep	80 Nm ²⁾
Z	pilot pressure port (only DA4/8) ³⁾	DIN 3852	M10x1; 8 deep	30 Nm ²⁾
Y	pilot pressure port (only DA7)	DIN 3852	M14x1.5; 12 deep	80 Nm ²⁾

¹⁾ ANSI B92.1a-1976, 30° pressure angle, flat root, side fit, tolerance class 5

²⁾ Please observe the general notes for the max. tightening torques on page 44

³⁾ Plugged

Unit Dimensions, Size 45

Before finalizing your design, please request a binding installation drawing. Dimensions in mm.

Hydraulic control, pilot-pressure related, HD

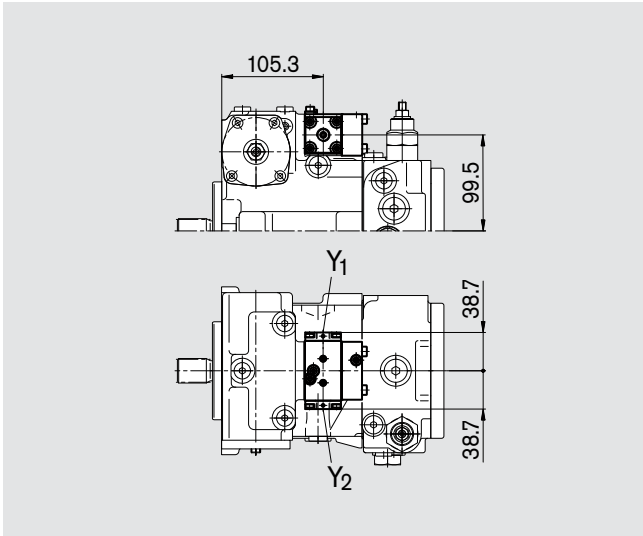

Hydraulic control, mechanical servo, HW

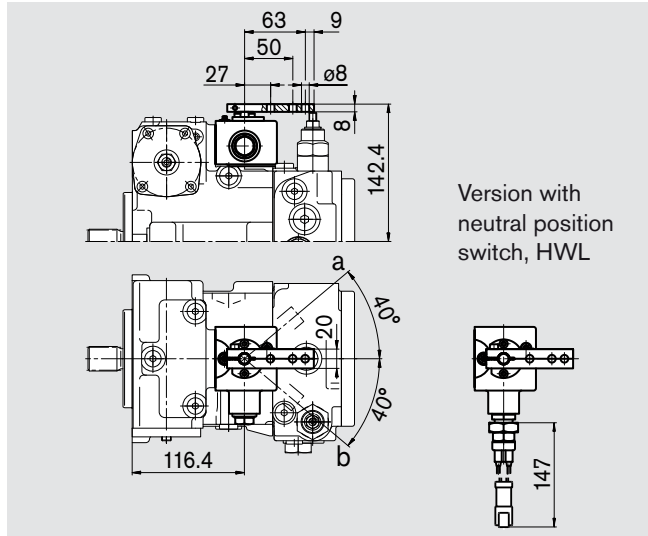

Electric two-position control with switching solenoid, EZ

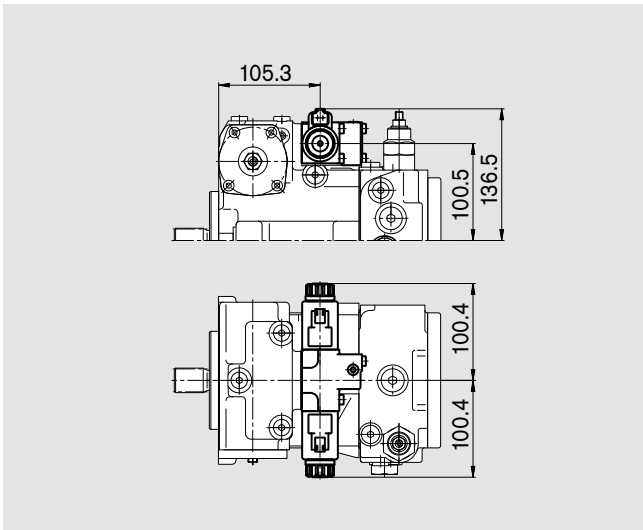

Electric control with proportional solenoid, EP

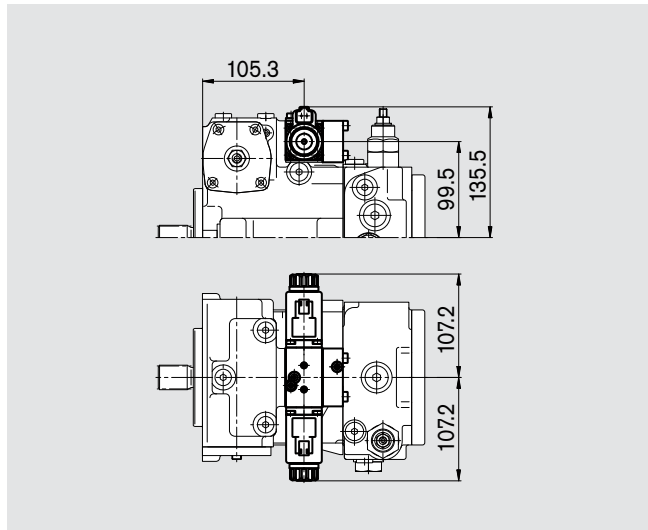

Pressure cut-off, D

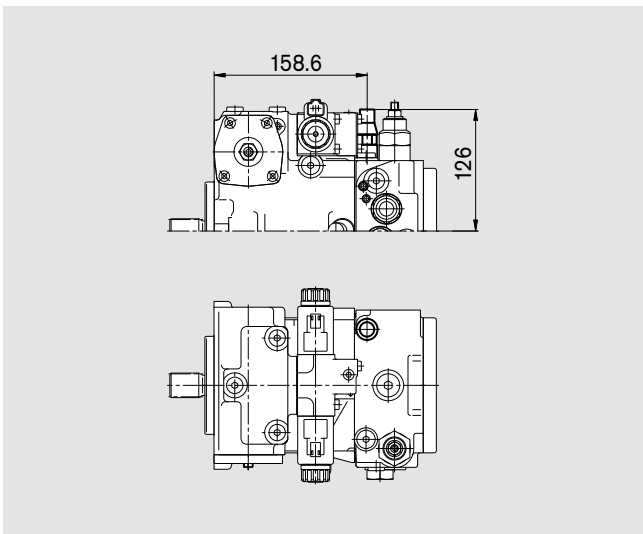

Unit Dimensions, Size 45

Before finalizing your design, please request a binding installation drawing. Dimensions in mm.

Hydraulic control, speed related, DA

Control valve, fixed setting, DA2

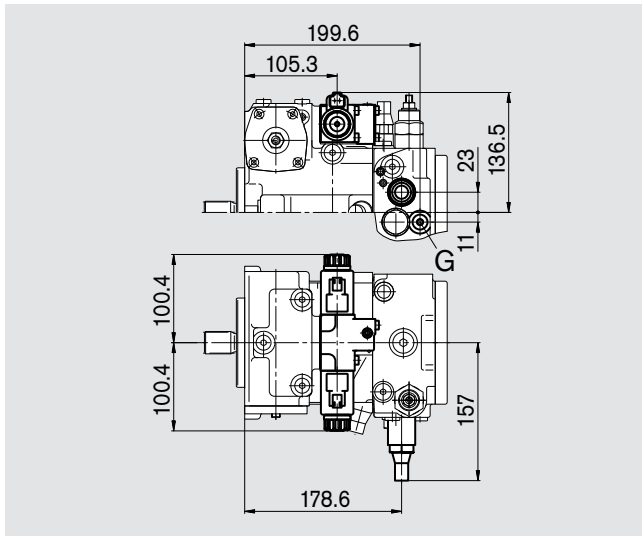

Control valve, fixed setting and hydraulic inch valve mounted, DA4/DA8

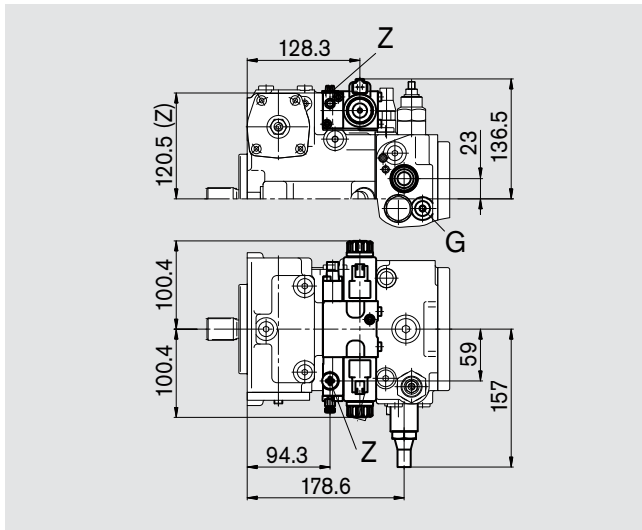

Control valve, mech. adjustable with position lever, DA3

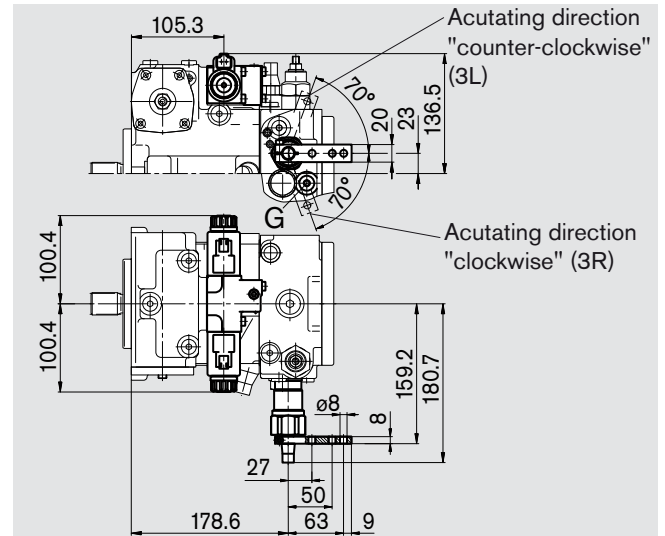

Control valve, fixed setting and ports for pilot control device DA7

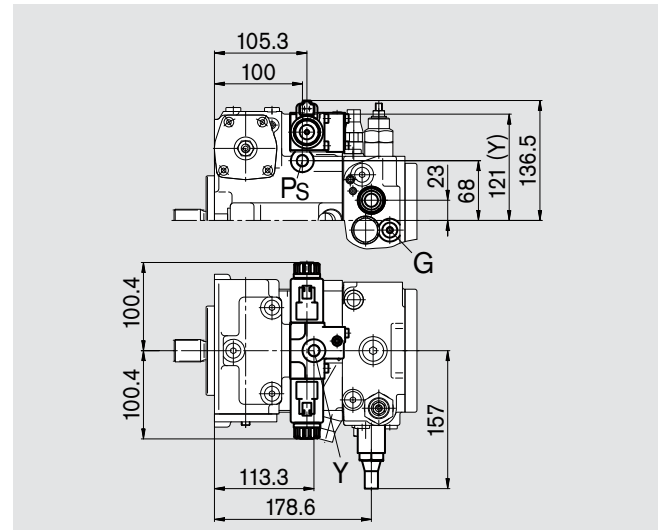

Important:

Position and size of port G on version with DA control valve

G DIN 3852 M12x1.5; 12 deep 50 Nm ¹⁾

¹⁾ Please observe the general notes for the max. tightening torques on page 44

Unit Dimensions, Size 63

Hydraulic control, direct operated, DG

Before finalizing your design, please request a binding installation drawing. Dimensions in mm.

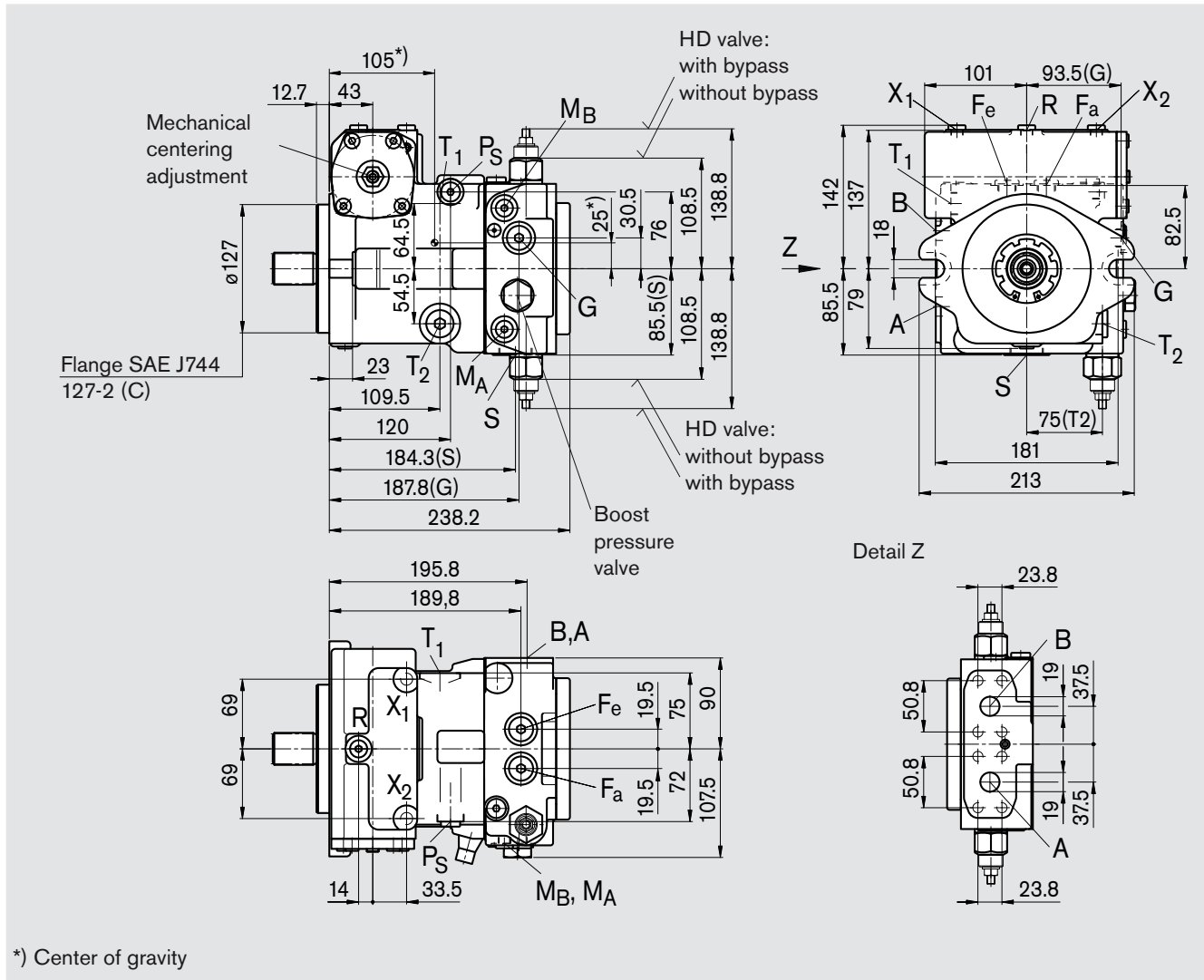

*) Center of gravity

Unit Dimensions, Size 63

Before finalizing your design, please request a binding installation drawing. Dimensions in mm.

Shaft ends

S Splined shaft 1 1/4in
14T 12/24DP ¹⁾
(SAE J744 – 32-4 (C))

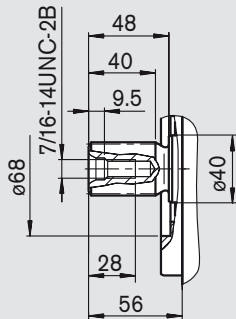

T Splined shaft 1 3/8in
21T 16/32DP ¹⁾

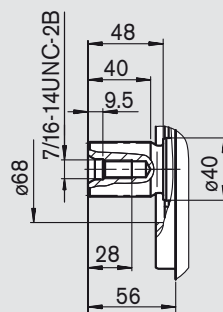

Ports

A, B	service line ports (high-pressure series) fixing thread A/B	SAE J518 DIN 13	3/4 in M10x1.5; 17 deep ²⁾
T ₁	case drain or fill	DIN 3852	M22x1.5; 14 deep 210 Nm ²⁾
T ₂	case drain ³⁾	DIN 3852	M22x1.5; 14 deep 210 Nm ²⁾
M _A , M _B	pressure gauge - operating pressure A, B ³⁾	DIN 3852	M12x1.5; 12 deep 50 Nm ²⁾
R	air bleed ³⁾	DIN 3852	M12x1.5; 12 deep 50 Nm ²⁾
S	boost suction port	DIN 3852	M33x2; 18 deep 540 Nm ²⁾
X ₁ , X ₂	ports for control pressure (before orifice) ³⁾	DIN 3852	M12x1.5; 12 deep 50 Nm ²⁾
G	pressure port for auxiliary circuits ³⁾	DIN 3852	M18x1.5; 12 deep 140 Nm ²⁾
P _S	control pressure supply, boost pressure ³⁾	DIN 3852	M14x1.5; 12 deep 80 Nm ²⁾
F _a	filter output ³⁾	DIN 3852	M18x1.5; 12 deep 140 Nm ²⁾
F _e	filter input ³⁾	DIN 3852	M18x1.5; 12 deep 140 Nm ²⁾
Y ₁ , Y ₂	remote control ports (only HD)	DIN 3852	M14x1.5; 12 deep 80 Nm ²⁾
M _H	port for balanced high pressure ³⁾ (only with pressure cut-off)	DIN 3852	M12x1.5; 12 deep 50 Nm ²⁾
Z	pilot pressure port (only DA4/8) ³⁾	DIN 3852	M10x1; 8 deep 30 Nm ²⁾
Y	pilot pressure port (only DA7)	DIN 3852	M14x1.5; 12 deep 80 Nm ²⁾

¹⁾ ANSI B92.1a-1976, 30° pressure angle, flat root, side fit, tolerance class 5

²⁾ Please observe the general notes for the max. tightening torques on 44

³⁾ Plugged

Unit Dimensions, Size 63

Before finalizing your design, please request a binding installation drawing. Dimensions in mm.

Hydraulic control, pilot-pressure related, HD

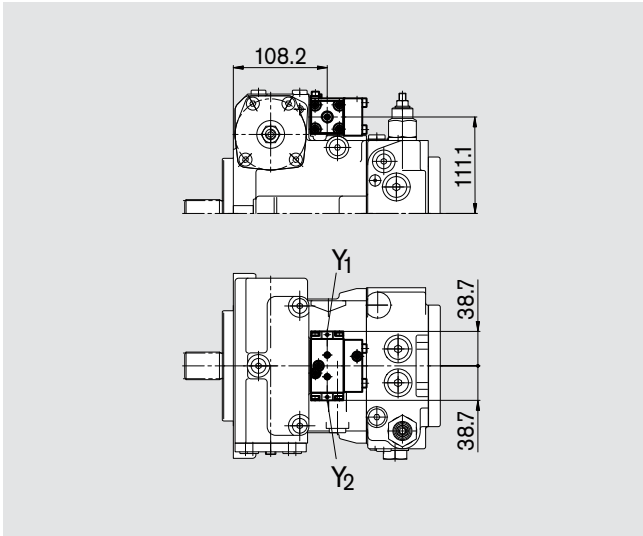

Hydraulic control, mechanical servo, HW

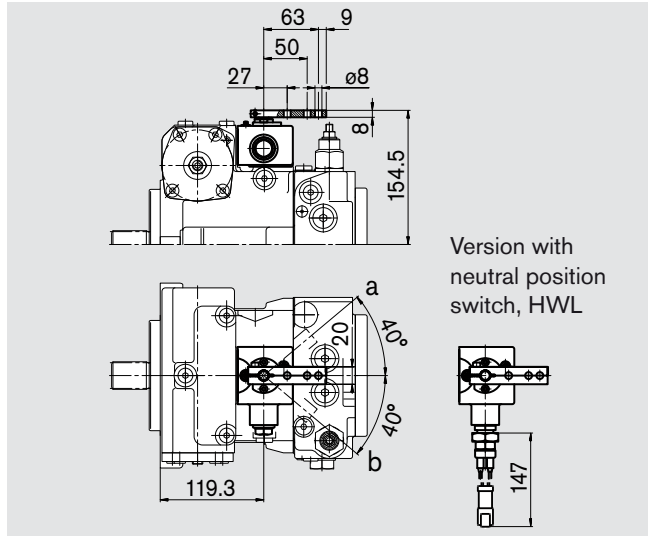

Electric two-position control with switching solenoid, EZ

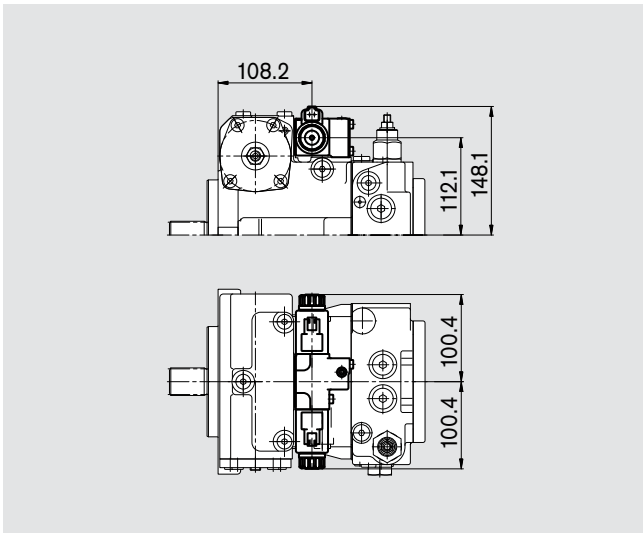

Electric control with proportional solenoid, EP

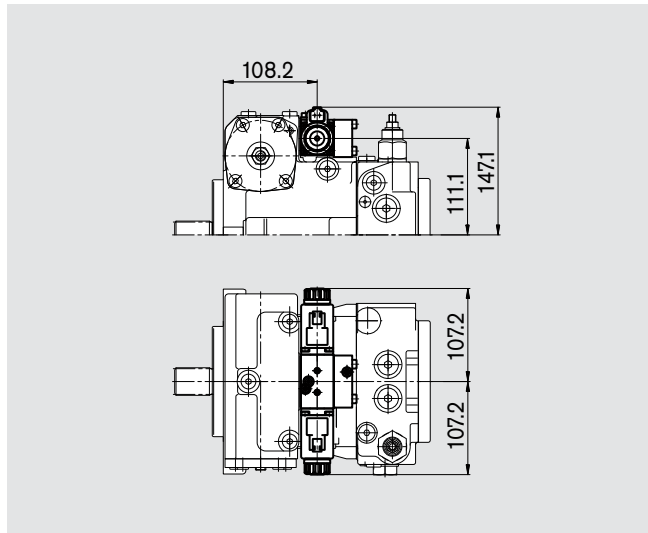

Pressure cut-off, D

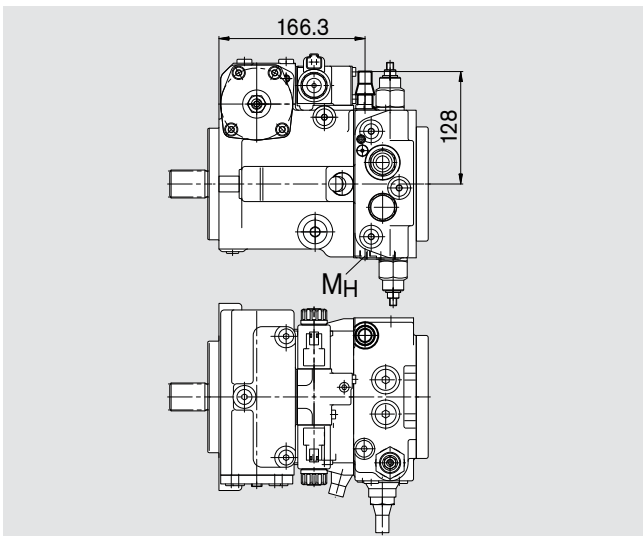

Unit Dimensions, Size 63

Before finalizing your design, please request a binding installation drawing. Dimensions in mm.

Hydraulic control, speed related, DA

Control valve, fixed setting, DA2

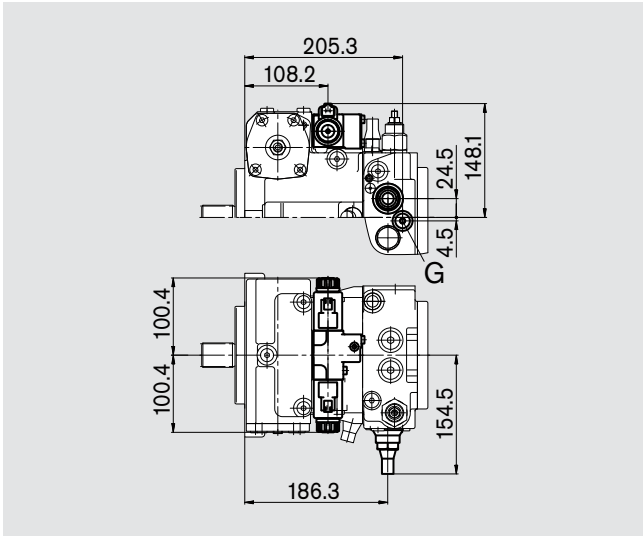

Control valve, fixed setting and hydraulic inch valve mounted, DA4/DA8

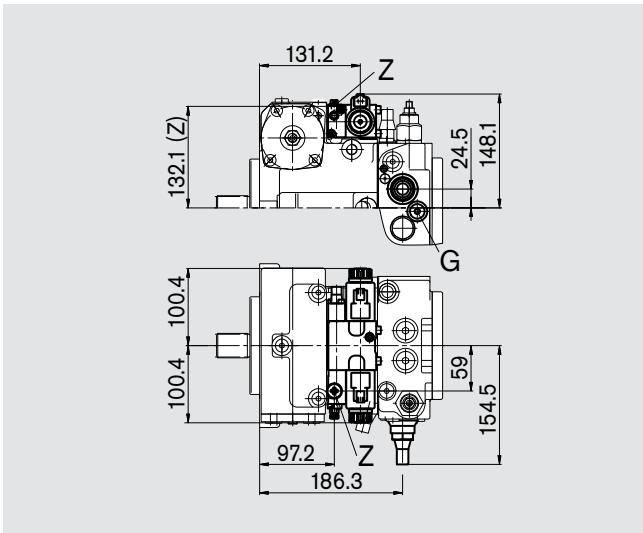

Control valve, mech. adjustable with position lever, DA3

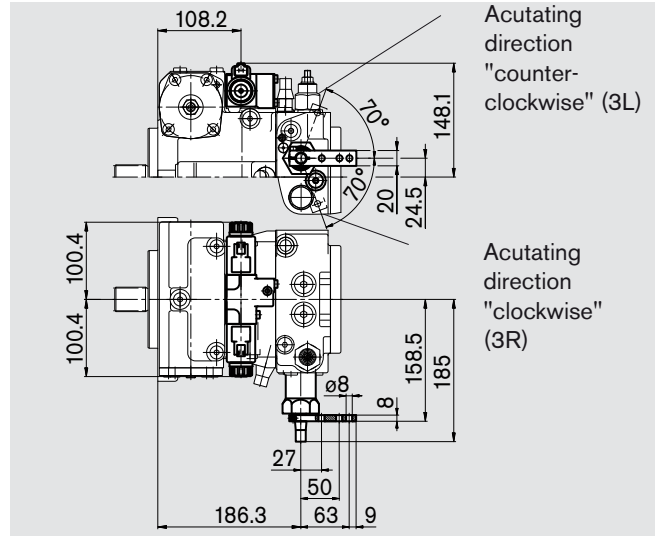

Control valve, fixed setting and ports for pilot control device, DA7

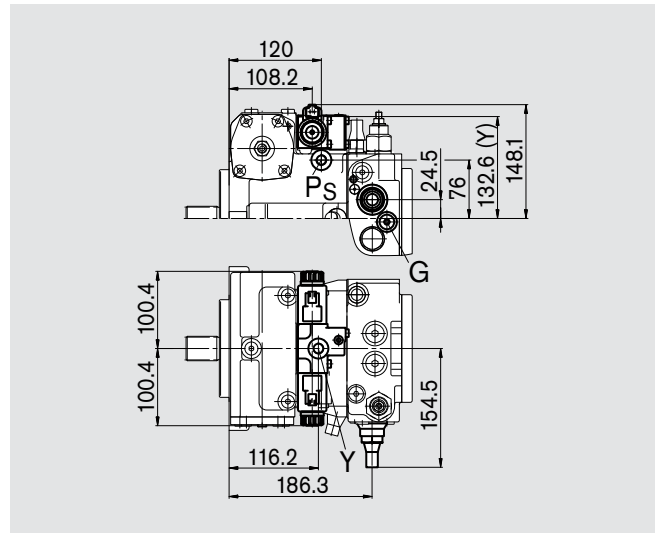

Important:

Position and size of port G on version with DA control valve

G DIN 3852 M14x1.5; 12 deep 80 Nm ¹⁾

¹⁾ Please observe the general notes for the max. tightening torques on 44

Through Drive Dimensions

Before finalizing your design, please request a binding installation drawing. Dimensions in mm.

N00 Without boost pump, without through drive
F00 With boost pump, without through drive

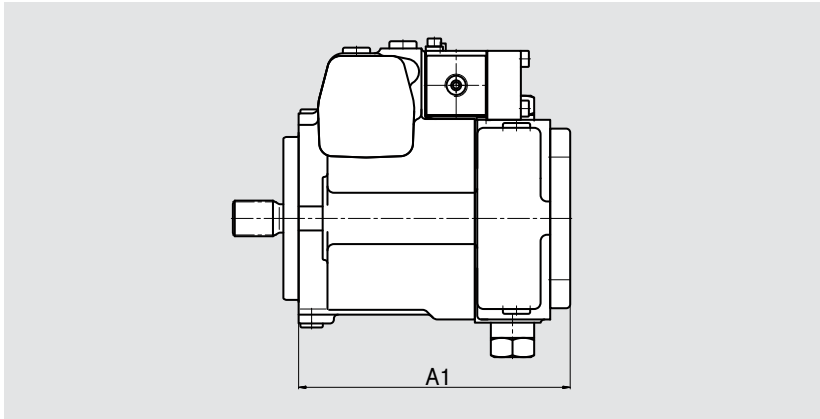

Size	A1 (N00)	A1 (F00)
18	169.4	169.4
28	201.7	215.3
45	216.8	230.5
63	224.5	238.2

F01/K01 Flange SAE J744 – 82-2 (A)

Hub for splined shaft according to ANSI B92.1a-1976 5/8in 9T 16/32DP¹⁾ (SAE J744 – 16-4 (A))

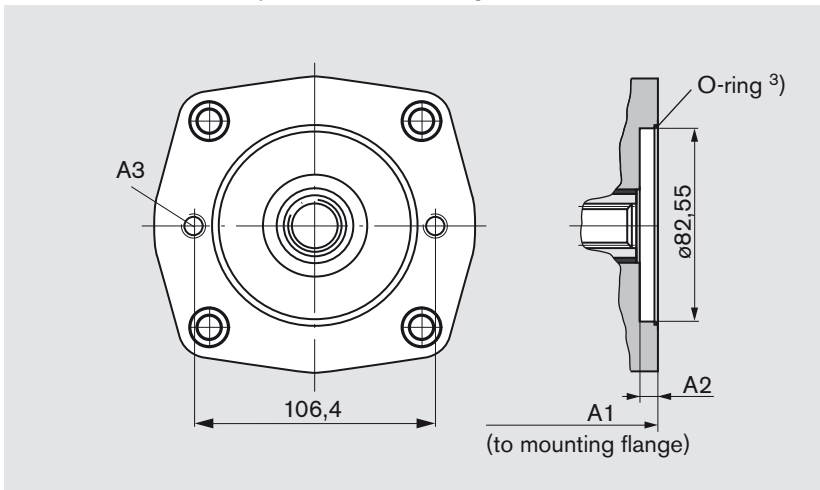

Size	A1	A2	A3 ²⁾
18	178.4	9	M10x1.5; 15 deep
28	219.2	9	M10x1.5; 17.5 deep
45	234.5	9	M10x1.5; 17.5 deep
63	242.2	9	M10x1.5; 17.5 deep

F02/K02 Flange SAE J744 – 101-2 (B)

Hub for splined shaft according to ANSI B92.1a-1976 7/8in 13T 16/32DP¹⁾ (SAE J744 – 22-4 (B))

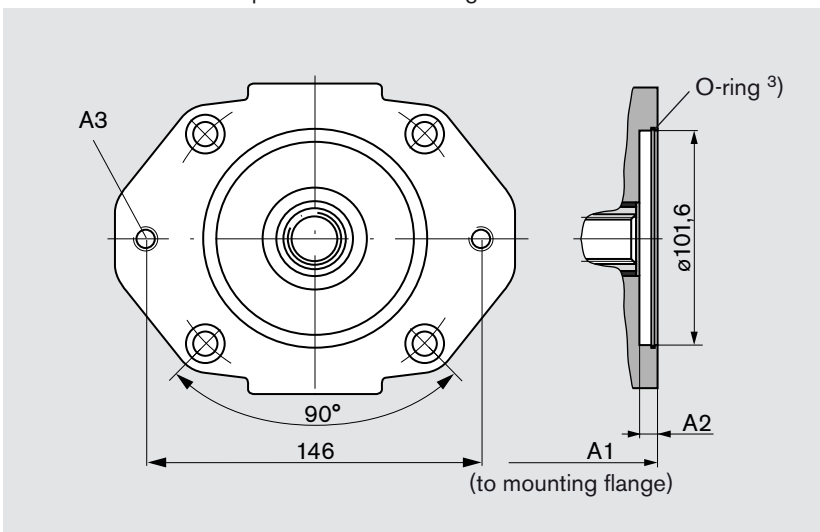

Size	A1	A2	A3 ²⁾
18	187.4	10	M12x1.75; 18 deep
28	220.2	10	M12x1.75; 18.5 deep
45	235.5	10	M12x1.75; 18.5 deep
63	243.2	10	M12x1.75; 18.5 deep

¹⁾ 30° pressure angle, flat root, side fit, tolerance class 5

²⁾ Thread acc. to DIN 13, please observe the general notes for the max. tightening torques on 44

³⁾ O-ring included in supply

Note: the mounting flange can be turned through 90°. Standard position is shown. Please state in plain text if required.

Through Drive Dimensions

Before finalizing your design, please request a binding installation drawing. Dimensions in mm.

F04/K04 Flange SAE J744 – 101-2 (B)

Hub for splined shaft according to ANSI B92.1a-1976 1 in 15T 16/32DP ¹⁾ (SAE J744 – 25-4 (B-B))

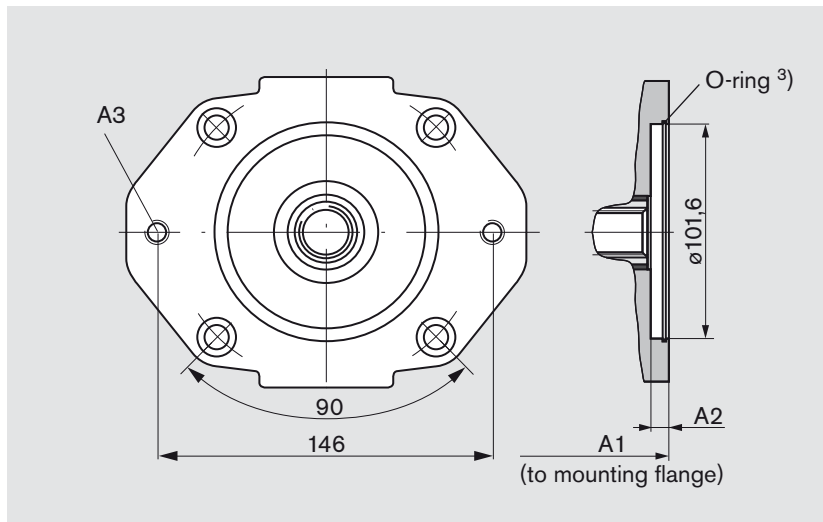

Size	A1	A2	A3 ²⁾
28	220.2	10	M12x1.75; 18.5 deep
45	235.5	10	M12x1.75; 18.5 deep
63	243.2	10	M12x1.75; 18.5 deep

F07/K07 Flange SAE J744 – 127-2 (C)

Hub for splined shaft according to ANSI B92.1a-1976 1 1/4in 14T 12/24DP ¹⁾ (SAE J744 – 32-4 (C))

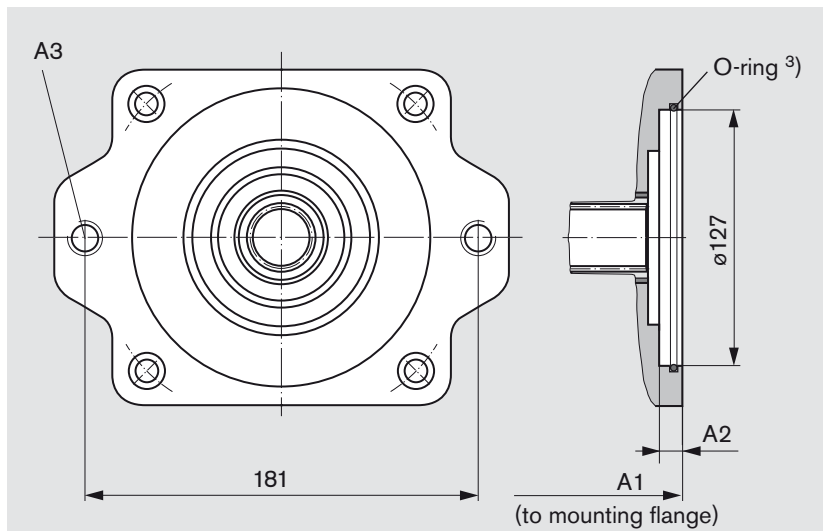

Size	A1	A2	A3 ²⁾
63	249.5	14	M16x2; 24.8 deep

¹⁾ 30° pressure angle, flat root, side fit, tolerance class 5

²⁾ Thread acc. to DIN 13, please observe the general notes for the max. tightening torques on 44

³⁾ O-ring included in supply

Note: the mounting flange can be turned through 90°. Standard position is shown. Please state in plain text if required.

Overview of Attachments on A10VG

Through drive – A10VG										Through drive
Flange	Hub for splined shaft	Code	A10VG Size (shaft)	A4VG Size (shaft)	A10V(S)O/31 Size (shaft)	A10V(S)O/53 Size (shaft)	A4FO Size (shaft)	A11VO Size (shaft)	External gear pump	Available for size
82-2 (A)	5/8 in	F/K01	–	–	18 (U)	10 (U)	–	–	size F size 4-22 ¹⁾	18...63
101-2 (B)	7/8 in	F/K02	18 (S)	–	28 (S,R)	28 (S,R)	16 (S) 22 (S)	–	Size N size 20-32 ¹⁾	18...63
	1 in	F/K04	28 (S) 45 (S)	28 (S)	45 (S,R)	45 (S,R) 60 (U,W)	–	40 (S)	–	
127-2 (C)	1 1/4 in	F/K07	63 (S)	40 (S), 56 (S) 71 (S)	71 (S,R) 100 (U)	85 (U)	–	60 (S)	–	63

¹⁾ Rexroth recommends special gear pump versions. Please contact us.

Combination Pumps A10VG + A10VG

Overall length A

A10VG (1st pump)	A10VG (2nd pump) ¹⁾			
	Size 18	Size 28	Size 45	Size 63
Size 18	356.8	–	–	–
Size 28	389.6	435.5	–	–
Size 45	404.9	450.8	466.0	–
Size 63	412.6	458.5	473.7	487.7

¹⁾ 2nd pump without through drive and with boost pump, F00

Combination pumps make it possible to have independent circuits without the need to fit splitter gearboxes.

When ordering combination pumps, the type designations of the 1st and 2nd pumps must be linked by a "+".

Example of order:

A10VG45HW1/10R-NTC10F04 + A10VG45HW1/10R-NSC10F00

A tandem pump combined of two equal sizes is permissible without additional supports where the dynamic acceleration does not exceed max. 10g (= 98.1 m/s²).

For combination pumps consisting of more than two pumps, the mounting flange must be rated for the permissible mass torque.

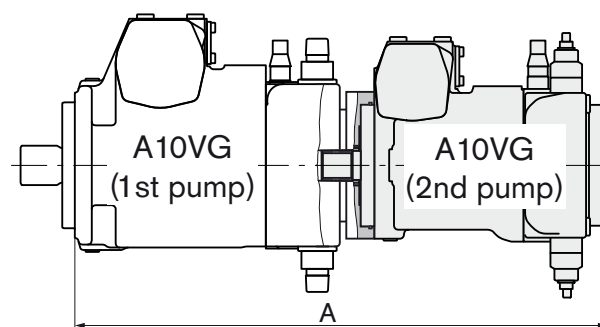

Mechanical Stroke Limiter, M

The mechanical stroke limiter is an additional function allowing continuous reduction of the maximum displacement of the pump, regardless of the control unit used.

The stroke of the stroke cylinder and hence the maximum swivel angle of the pump are limited by means of two adjusting screws.

Dimensions

Size	M1	M2	M3	M4
18	94.9	96.9	18	42.1
28	99	99	21.5	35
45	101.6	101.6	22.5	35.5
63	124	124	26.5	43

Circuit diagram

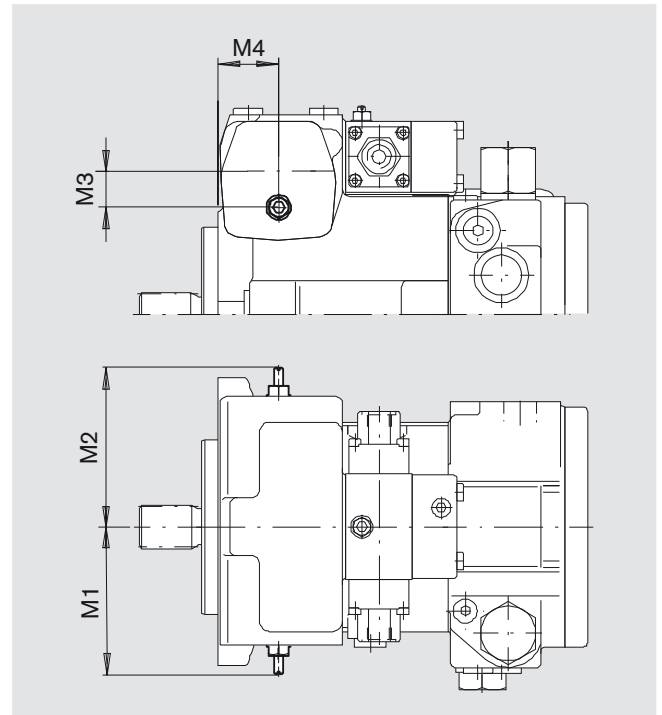
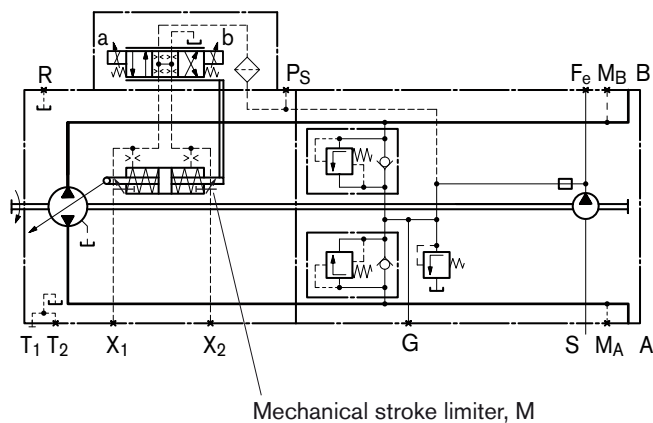

Filtration Types

Standard: Filtration in the suction line of the boost pump, S

Standard version (preferred)

Filter type: _____ filter **without** bypass

Recommendation: _____ **with** contamination indicator

Flow resistance at the filter element:

at $v = 30 \text{ mm}^2/\text{s}$, $n = n_{\text{max}}$ _____ $\Delta p \leq 0.1 \text{ bar}$

at $v = 1000 \text{ mm}^2/\text{s}$, $n = n_{\text{max}}$ _____ $\Delta p \leq 0.3 \text{ bar}$

Pressure at port S of the boost pump:

at $v = 30 \text{ mm}^2/\text{s}$ _____ $p \geq 0.8 \text{ bar}$

at cold start ($v = 1600 \text{ mm}^2/\text{s}$, $n \leq 1000 \text{ rpm}$) _____ $p \geq 0.5 \text{ bar}$

Filter is not included in supply.

Circuit diagram - standard version S

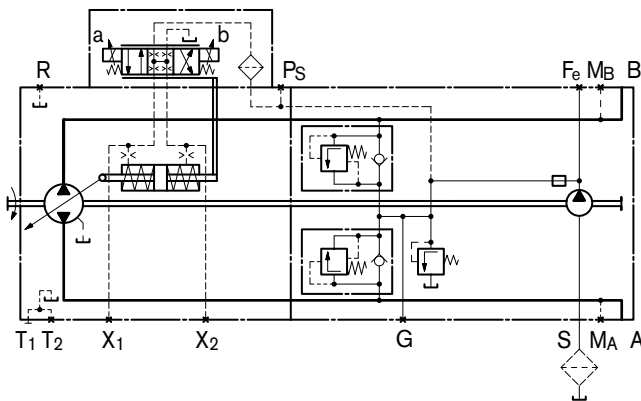

Variation: External supply, E

This variation should be used in versions **without** integral boost pump (N00 or K..).

The supply is provided as follows:

Size 18 _____ port S

Size 28, 45 (without DA control valve) _____ port G

Sizes 28, 45 (with DA control valve) _____ port Fe

Size 63 _____ port Fa

With size 28, 45 and 63, port S is closed.

Filter arrangement: _____ separate

For functional reliability ensure required cleanliness level for the boost pressure fluid (see page 6).

Circuit diagram variation E (external supply)

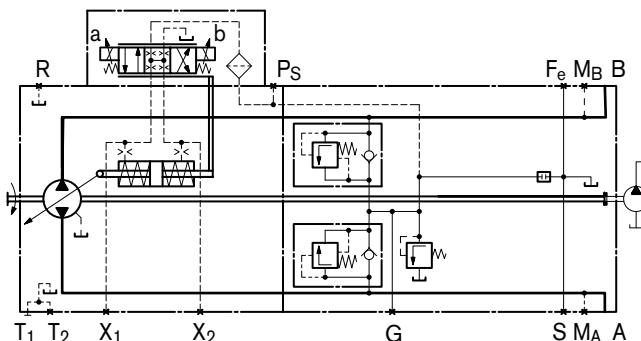

Variation:

Filtration in the pressure line of the boost pump, ports for external boost circuit filter, D

Filter input: _____ Port Fe

Filter output: Size 63 Port Fa
Size 28, 45 Port G (Fa)

Filter type: Filter with bypass are **not recommended**.
When applying with bypass please consult us.

Recommendation: **with** contamination indicator

Note:

- In conjunction with a DA control valve, no pressure filtration is possible with size 28, 45 (refer to ordering code, page 4).
- With sizes 28, 45, port G serves as "filter output Fa".

Note:

For versions with **DG** control (with pilot pressure not from boost circuit), the following filter type should be employed:

Filter **with** bypass and **with** contamination indicator

Filter arrangement: separately in the pressure line (line filter)

Flow resistance at the filter element:

at $v = 30 \text{ mm}^2/\text{s}$ _____ $\Delta p \leq 1 \text{ bar}$

for cold start _____ $\Delta p \leq 3 \text{ bar}$

(valid for entire speed range $n_{\text{min}} - n_{\text{max}}$)

Filter is not included in supply.

Circuit diagram variation D

Size 28, 45

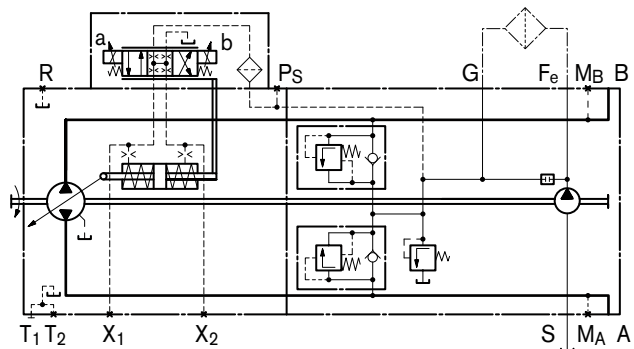

Size 63

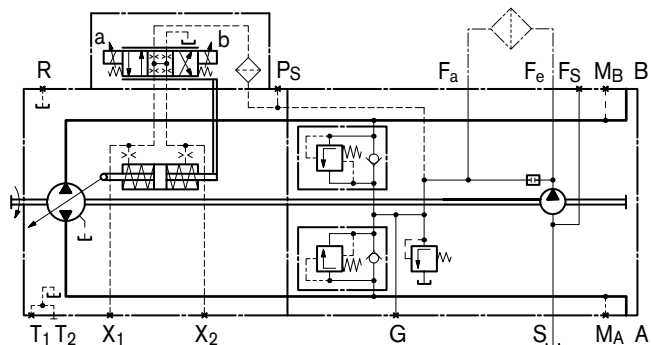

Connector for Solenoids (Only for EP, EZ, DA)

DEUTSCH DT04-2P-EP04, 2-pin

Molded, without bi-directional suppressor diode (standard) **_P**

Molded, with bi-directional suppressor diode
(only for switching solenoids on control unit EZ1/2, DA) **___Q**

Type of protection according to DIN/EN 60529: IP67 and IP69K

The protection circuit with a bi-directional suppressor diode is necessary for limiting overvoltages. Overvoltages are generated by disconnecting the current using switches, relay contacts or by unplugging an energized mating connector.

Circuit symbol

without bi-directional suppressor diode

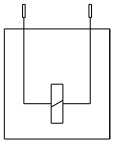

with bi-directional suppressor diode

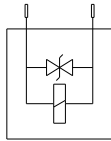

Mating connector

DEUTSCH DT06-2S-EP04
Rexroth Mat. No. R902601804

consisting of: DT designation
 – 1 case _____ DT06-2S-EP04
 – 1 wedge _____ W2S
 – 2 sockets _____ 0462-201-16141

The mating connector is not included in supply.
This can be supplied by Rexroth on request.

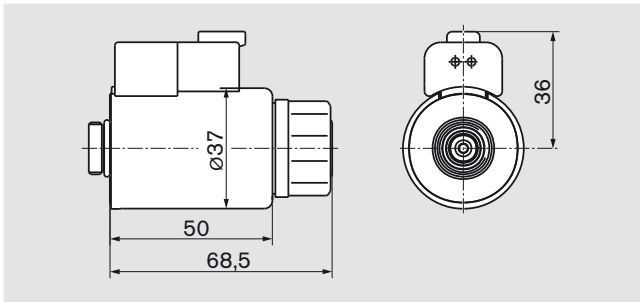

Note for round solenoids:

The position of the connector can be changed by turning the solenoid body.

Proceed as follows:

1. Loosen the fixing nut (1)
2. Turn the solenoid body (2) to the desired position
3. Tighten the fixing nut
Tightening torque of the fixing nut: 5⁺¹ Nm
(width across flats WAF26, 12-sided DIN 3124)

Rotary Inch Valve

The rotary inch valve permits the control pressure to be reduced, independent from the drive speed through the mechanical operation of the actuating lever. Maximum rotation angle 90°. The lever may be fixed in any position.

The valve is mounted separately from the pump and connected with a pump by the hydraulic control line at port P_S (max. line length approximately 2 meters).

The rotary inch valve must be ordered separately.

Size	Material no.	Direction of actuation of position lever
18, 28, 45, 63	R902048734	clockwise
	R902048735	counter-clockwise

Attention:

The rotary inch valve can be used independently from the control unit.

Circuit diagram:

hydraulic control, speed related, DA
with separate rotary inching valve

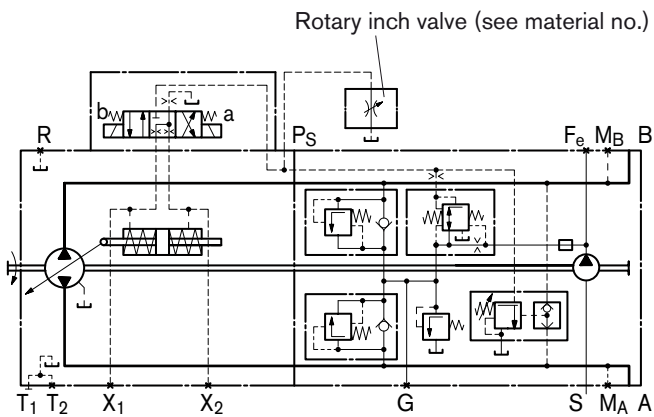

Unit dimensions

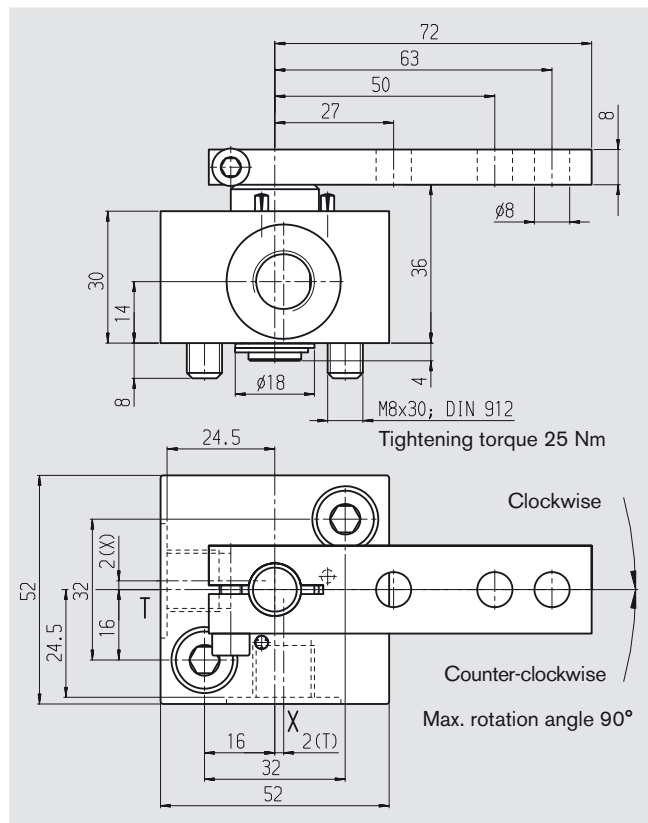

Ports

X	pressure port DIN 3852	M14x1.5; 12 deep	80 Nm ¹⁾
T	drain tank DIN 3852	M14x1.5; 12 deep	80 Nm ¹⁾

¹⁾ Please observe the general notes for the max. tightening torques on page 44

Installation Situation for Coupling Assembly

To ensure that rotating components (coupling hub) and fixed components (case, retaining ring) do not come into contact with each other, the installation conditions described here must be observed. This depends on the size and the splined shaft.

Size 18...45 (with free turning):

– Please observe diameter of the free turning.

Size 63 (without free turning):

– The outer diameter of the coupling hub must be smaller than the inner diameter of the retaining ring d_2 in the zone of the drive shaft collar (dimension $x_2 - x_4$).

SAE splined shaft (spline acc. to ANSI B92.1 a-1976)

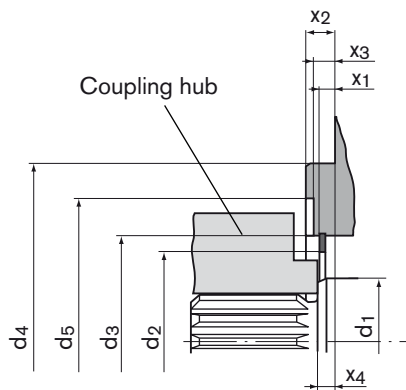

Size	$\varnothing d_1$	$\varnothing d_{2 \text{ min}}$	$\varnothing d_3$	$\varnothing d_4$	$\varnothing d_5$	x_1	x_2	x_3	x_4
18	30	36.1	49 ± 0.1	101.6	65	$5.9^{+0.2}$	$9.5_{-0.5}$	7	$8^{+0.9}_{-0.6}$
28	(35)	43.4	55 ± 0.1	101.6	72	$3.9^{+0.2}$	$9.5_{-0.5}$	7	$8^{+0.9}_{-0.6}$
45	40	51.4	63 ± 0.1	101.6	80	$4.3^{+0.2}$	$9.5_{-0.5}$	7	$8^{+0.9}_{-0.6}$
63	40	54.4	68 ± 0.1	127	–	$7.0^{+0.2}$	$12.7_{-0.5}$	–	$8^{+0.9}_{-0.6}$

Installation Notes

General

During commissioning and operation, the axial piston unit must be filled with hydraulic fluid and air bled. This is also to be observed following a relatively long standstill as the system may empty via the hydraulic lines.

The pump case drain connection (i.e. T₁/T₂) must be directed to the tank via the highest case drain port. The minimum suction pressure at port S must not fall below 0.8 bar abs. (cold start 0.5 bar absolute).

In all operating states, the suction line and case drain line must flow into the tank below the minimum fluid level.

Installation position

See examples below. Additional installation positions are available upon request.

Below-tank installation (standard)

Pump below the minimum fluid level of the tank.

Recommended installation positions: 1 and 2.

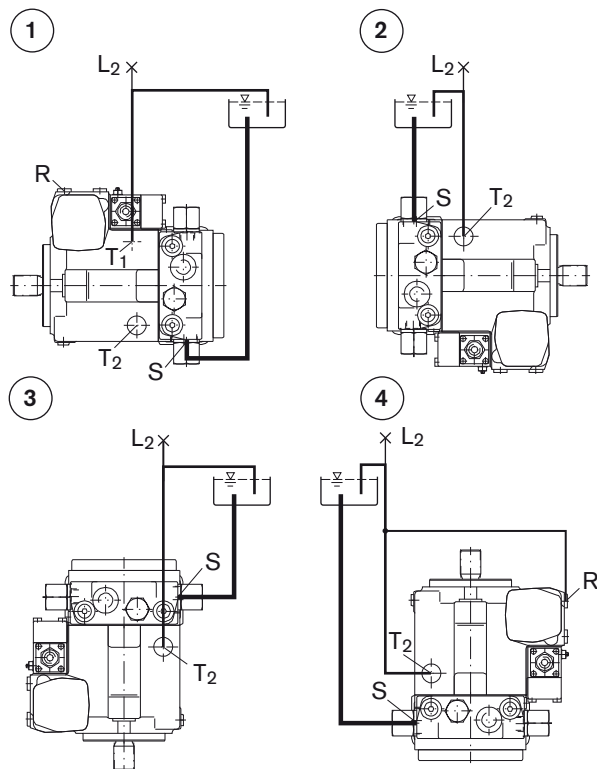

Above-tank installation

Pump above the min. fluid level of the tank

Observe the maximum permissible suction height $h_{max} = 800$ mm.

Recommendation for installation position 8 (shaft upwards):

A check valve in the case drain line (opening pressure 0.5 bar) can prevent draining of the case interior.

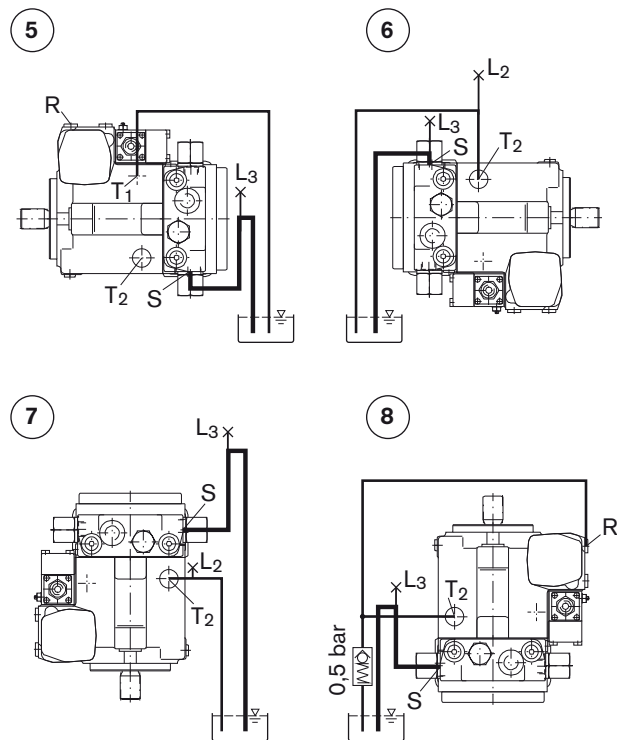

Installation position	Air bleeding	Filling
1	R	S + T ₁ (L ₂)
2	L ₂	S + T ₂ (L ₂)
3	L ₂	S + T ₂ (L ₂)
4	R + L ₂	S + T ₂ (L ₂)

Installation position	Air bleeding	Filling
5	R	T ₁ + (L ₃)
6	L ₂	S (L ₃) + T ₂ (L ₂)
7	L ₂ + L ₃	S (L ₃) + T ₂ (L ₂)
8	R + L ₃	S (L ₃) + T ₂

Notice

General Notes

- The A10VG pump is designed to be used in closed circuits.
- Project planning, assembly and commissioning of the pump require the involvement of qualified personnel.
- The service line ports and function ports are only designed to accommodate hydraulic lines.
- During and shortly after operation, there is a risk of burns on the pump and especially on the solenoids. Take suitable safety precautions, e.g. wear protective clothing
- There may be shifts in the characteristic depending on the operating state of the pump (operating pressure, fluid temperature).
- Tightening torques:
 - The tightening torques specified in this data sheet are maximum values and must not be exceeded (maximum values for screw thread).
Manufacturer's instruction for the max. permissible tightening torques of the used fittings must be observed!
 - For DIN 13 fixing screws, we recommend checking the tightening torque individually according to VDI 2230 Edition 2003.
- The data and information contained herein must be adhered to.