

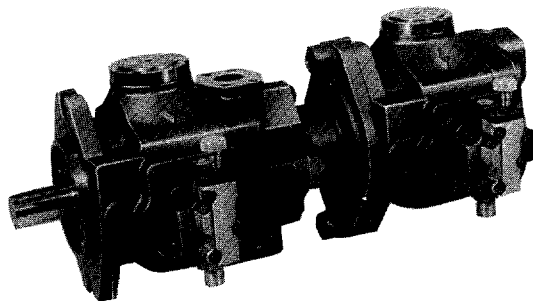

**BOSCH**

# REPAIR PARTS

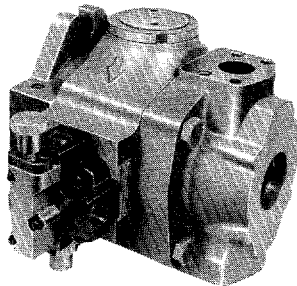

## VARIABLE VOLUME SILENTVANE PUMP

**MODEL SV-80**      1500 PSI  
60 GPM

**MODEL SV-100**      1000 PSI  
75 GPM

**FLANGE MOUNTED  
COMBINATION CAPABILITY**

WHEN ORDERING PARTS, FURNISH:

1. COMPLETE CODE NUMBER
2. PARTS REQUIRED
3. SHIPPING INSTRUCTIONS

WRITE FACTORY FOR NEAREST AUTHORIZED PARTS AND SERVICE CENTER.

## PUMP CODING

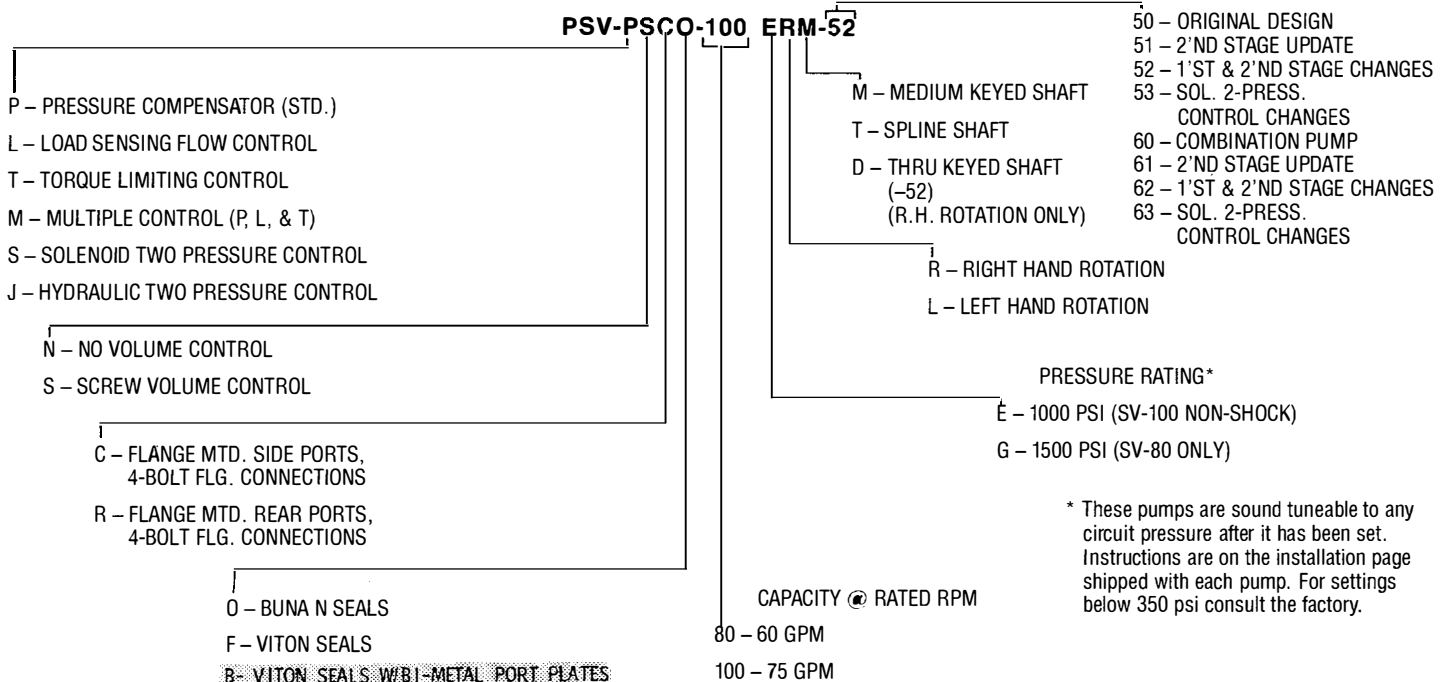

ASSY. INCLUDES:  
SHAFTSEAL, INSTALLATION  
SLEEVE AND INSTRUCTIONS

FLANGE MOUNTED, RIGHT HAND  
ROTATION PUMP SHOWN WITH  
MEDIUM KEYED SHAFT.

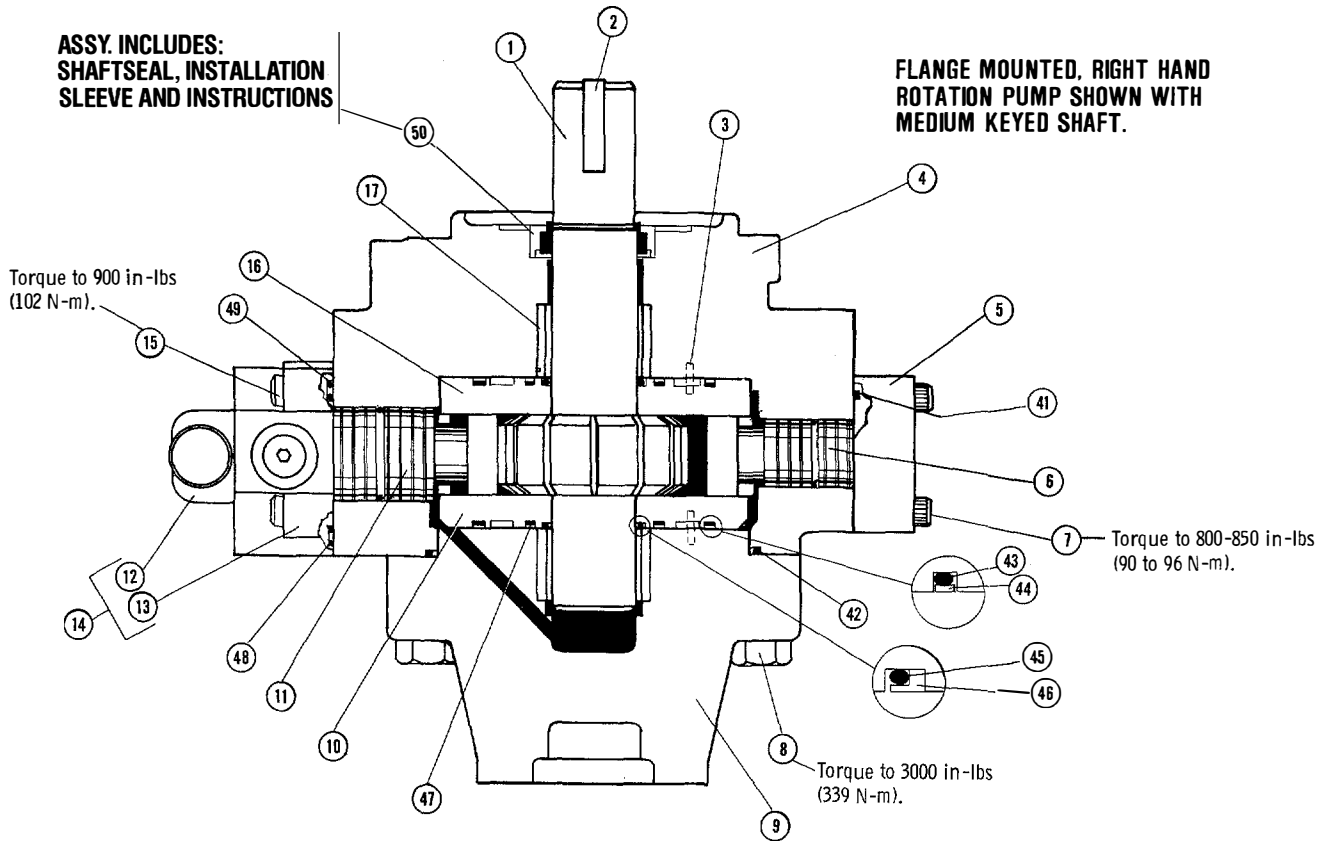

CAUTION! DO NOT EXCEED RECOMMENDED  
TORQUE VALUES.

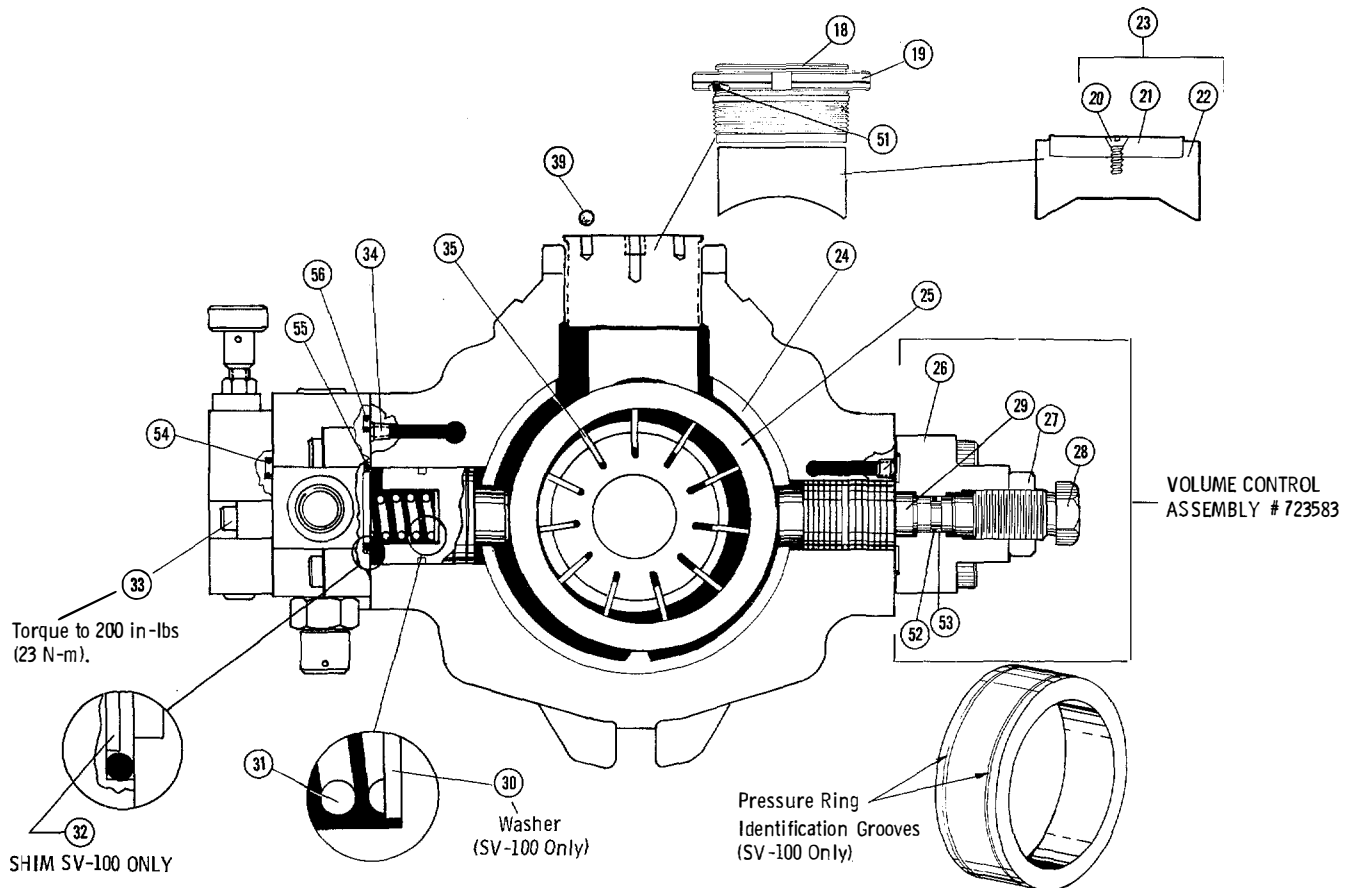

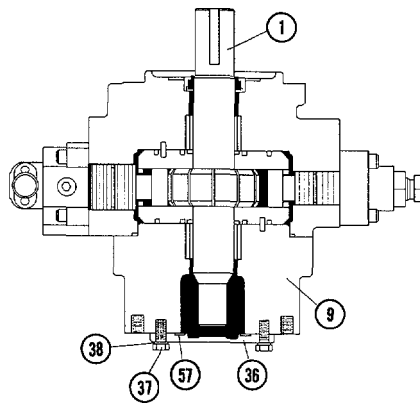

FLANGE MOUNTED  
R. H. ROTATION SHOWN  
WITH MEDIUM COMBINATION SHAFT.

Ref. No.	Part No.	Description	Qty.	Ref. No.	Part No.	Description	Qty.
1	308417	Rotor Shaft, Keyed (For Rear Port Cover Only)	1	17	723135	Bearing Assembly	2
1	308530	Rotor Shaft, Splined	1	18	309041	Stationary Plug	1
1	308567	Rotor Shaft, Thru (-52)	1	19	309044	Lock Ring	1
1	308988	Rotor Shaft, Combination (-62)	1	20	401215	Screw, 8-32 x 3/8	2
2	490965	Key	1/2	21	309042	Plastic Disc	1
3	401717	Roll Pin	4	22	778490	Thrust Block (-62)	1
4	222804	Body, R.H. Rotation	1	23	778449	Thrust Block Assy. (-62)	1
4	222803	Body, L.H. Rotation	1	24	308418	Spacer Ring	1
5	222601	Bias Cover	1	25	308419	Pressure Ring (SV80)	1
6	308421	Bias Piston	1	25	308803	Pressure Ring (SV100)	1
7	408892	Screw, 7/16-14 x 2	4	26	222600	Body, Volume Control	1
8	405198	Screw, 3/4-10 x 3-1/4	4	27	401019	Hex Nut	1
9	222790	Cover, Side Ported (-52)	1	28	308412	Adjusting Screw	1
9	222806	Cover, Thru Shaft (-52)	1	29	308414	Piston	1
9	222939	Cover, Rear Ported (-62)	1	30	408757	Washer (SV100 Only)	1
9	222959	Cover, Combination (-62)	1	31	490977	Spring	1
10	222749	Port Plate, R.H. Cover, L.H. Body	1	32	308998	Shim (SV100 Only)	1
10	778671	Port Plate, Bi-Metal, R.H. Cover	1	33	400779	Screw, 1/4-20 x 1-1/4	3
11	308422	Control Piston	1	34	400925	Plug, 1/16 NPTF	2
12	956120	2'nd Stage Assembly (SV80)	1	35	778279	Vane Set (11 pcs of 308429)	1
12	956121	2'nd Stage Assembly (SV100)	1	36	222975	End Cover	1
13	—	1'st Stage Assembly	1	37	400721	Screw, 3/8-16 x 7/8	2
14	956113	2-Stage Compensator Assy. (SV80) Complete	1	38	407799	Washer	2
14	956114	2-Stage Compensator Assy. (SV100) Complete	1	—	491854	Nameplate (Not Shown) SV Std.	1
15	406309	Screw, 7/16-14 x 1-3/4	4	—	492114	Rivet (Not Shown)	2
16	222747	Port Plate, R.H. Body, L.H. Cover	1	39	492143	Acetal Ball	2
16	778670	Port Plate, Bi-Metal, R.H. Body	1				

## SEAL KITS

### VITON SEALS

Ref. No.	Part No.	Description	Qty.
41	406130	O-Ring, 3/32 x 2-5/16 x 2-1/2	1
42	491031	O-Ring, 1/8 x 6-3/4 x 7	1
43	491032	O-Ring, 1/8 x 5 x 5-1/4	2
44	490983	Back-Up Ring	2
45	407109	O-Ring, 3/32 x 2-1/16 x 2-1/4	2
46	490979	Back-Up Ring	2
47	409146	O-Ring, 3/32 x 2-11/16 x 2-7/8	2
48	406565	O-Ring, 1/16 x 7/16 x 9/16	1
49	406265	O-Ring, 1/16 x 3/16 x 5/16	1
50	794449	Shaft Assembly — Teflon	1/2
51	406978	O-Ring, 1/8 x 2-7/8 x 3-1/2	1
52	406518	O-Ring, 3/32 x 9/16 x 3/4	2
53	491354	Back-Up Ring	1
54	406797	O-Ring, 1/16 x 5/16 x 7/16	3
55	406800	O-Ring, 3/32 x 2-3/16 x 2-3/8	1
56	406636	O-Ring, 3/32 x 3/8 x 9/16	1
57	492568	Gasket	1

Viton Seal Kits:

Single End Shaft & Combination . . . . . 723733

Double End Shaft . . . . . 794119

NOTE: DOUBLE ENDED SEAL KITS CONSIST OF ONE STD. KIT & ONE SHAFT SEAL.

## REPAIR KITS

Description	SV 80	SV 100
†Medium length keyed shaft – Viton	794101	794105
Splined shaft – Viton	794103	—
Thru shaft – Viton (-52)	794126	794127
Combo shaft – Viton (-62)	794405	794407
Combo shaft – Viton – Bi-Metal Plates	794482	794483

†USED WITH -52 DESIGN AND ALL REAR PORTED PUMPS.  
EACH KIT CONTAINS TWO BEARINGS, ONE ROTOR, ONE SET OF VANES, ONE PRESSURE RING,  
FOUR ROLL PINS, ONE OR TWO KEYS, ONE SEAL KIT AND TWO PORT PLATES.

THE DISTANCE ON -60 PUMPS FROM THE PUMP MOUNTING FLANGE TO THE CENTER OF THE PORT, DECREASED BY 1/8" (SV-80). A SPACER (#492548) CAN BE USED TO MAKE UP THE LOST DISTANCE.

**PORT CHANGES  
DASH-50 VS DASH-60 DESIGNS**

PUMP MODEL (Port Type)	DASH-50 DESIGN		DASH-60 DESIGN	
	INLET	OUTLET	INLET	OUTLET
SV-80/SV-100 (4-Bolt Flange)	2-1/2"	1-1/2"	2-1/2"	1-1/2"

**CONVERSION INFORMATION**

	SV-80	SV-100
Pressure Ring		308419
Shim (Control Piston)	Replace	None
Shim (Compensator)		None
		Replace With
		308803
		408757
		308998

\*When using a torque limiter control or an old style compensator (powdered metal with tear drop counterbore), use shim 492352.

When making any conversions, always remember to change the name tag coding.

Recalibrate pump according to specific pump size.

**SINGLE STAGE**

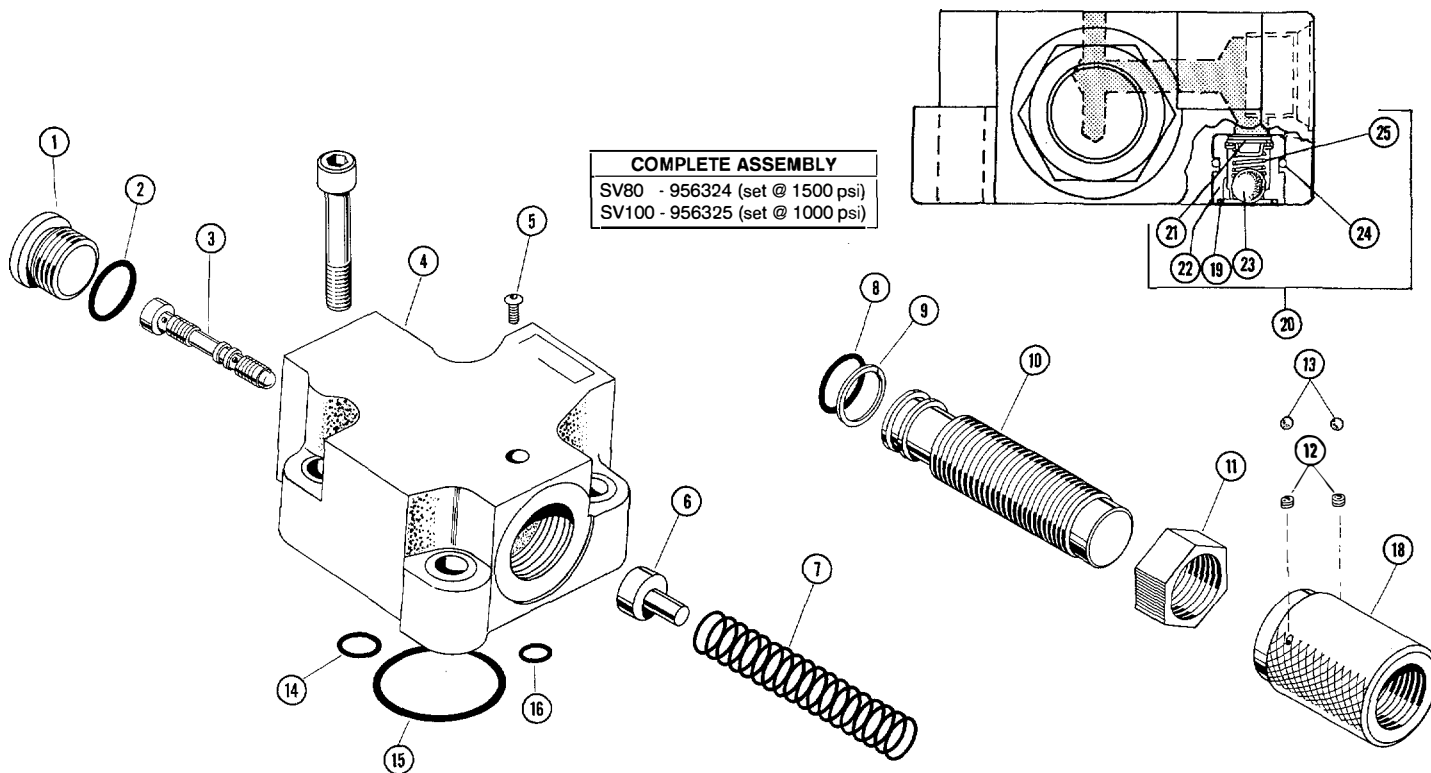

Ref. No.	Part No.	Description	Qty.
1	491832	#8 SAE Hollow Plug	1
*2	407139	O-Ring, Viton (-908)	1
3	309298	Spool	1
4	223111	Body (SAE)	1
5	457603	Screw #8-32 UNC x .25	1
6	309299	Spring Seat	1
7	457642	Spring	1
8	406707	O-Ring (-020) 7/8 x 1 x 1/16	1
9	457626	Back Up Ring	1
10	309300	Adjusting Barrel	1
11	309301	Lock Nut	1
12	457688	Set Screw 1/4-20 x 1/8	2
13	457689	Acetal Ball ø 9/64	2
*14	406636	O-Ring (-110) 3/8 x 9/16 x 3/32	1

Ref. No.	Part No.	Description	Qty.
*15	406800	O-Ring (-139) 2-3/16 x 2-3/8 x 3/32	1
*16	406265	O-Ring (-008) 3/16 x 5/16 x 1/16	1
17	406309	Screw (Not Included in Complete Assembly) 7/16-14 x 1-3/4	4
18	309302	Stop Nut & Knob	1
*19	406215	O-Ring (-014) 1/2 x 5/8 x 1/16	1
20	778413	Drain Check Assembly	1
	723673	Installation Seal Kit (Includes Ref. #14, 15, 16 & 19)	1
21	492394	Spring Retainer	1
22	309027	Body, Drain Check	1
23	490405	Steel Ball	1
24	406518	O-Ring, 3/32 x 9/16 x 3/4	1
25	492395	Spring	1

\*Included in Seal Kit #723733 (Viton)

# STANDARD TWO-STAGE COMPENSATOR—FIRST STAGE

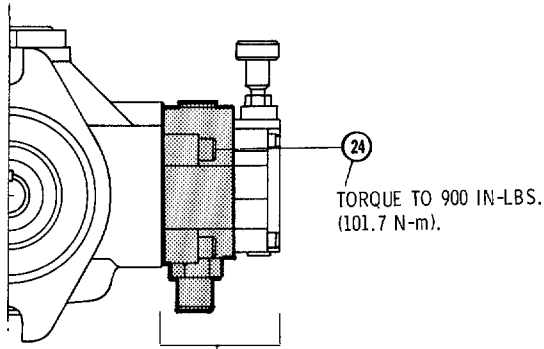

TORQUE TO 900 IN-LBS.  
(101.7 N-m).

COMPLETE TWO-STAGE  
PRESSURE COMPENSATOR  
( 1st & 2nd STAGES)  
SV- 80 956113  
SV- 100 956114

NOTE: THE FIRST STAGE CANNOT BE PURCHASED  
BY ITSELF. YOU HAVE TO PURCHASE THE  
COMPLETE COMPENSATOR TO GET THE  
FIRST STAGE.

- 51 DESIGN  
- 61 DESIGN

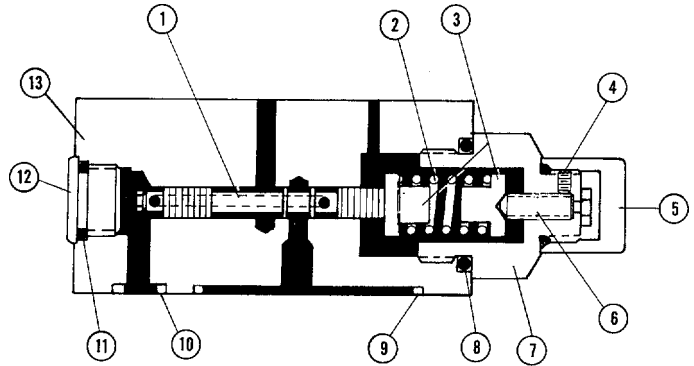

- 52 DESIGN  
- 62 DESIGN

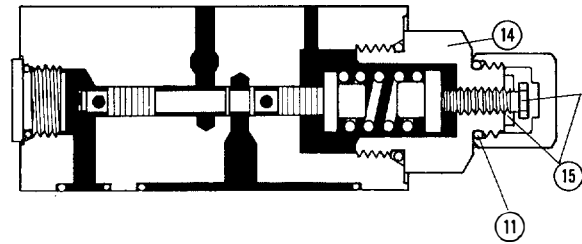

Ref. No.	Part No.	Description	Qty.
1	308747	Spool	1
2	491833	Spring	1
3	308744	Spring Seat	2
4	408637	Set Screw	1
5	308936	Safety Cap	1
6	308734	Adjusting Screw (Void)	1
7	308746	Adaptor, Adjusting Screw (Void)	1
* 8	407102	O-Ring, #14 SAE (-914)	1
* 9	406800	O-Ring, 3/32 x 2-3/16 x 2-3/8	1
* 10	406636	O-Ring, 3/32 x 5/16 x 7/16	1
* 11	407139	O-Ring, #8 SAE (-908)	2
12	491832	Plug, #8 SAE	1
13	223053	Body, 1st Stage	1
14	309053	Adaptor, Adjusting Screw	1
15	778459	Lock Nut — Adjusting Screw	1
17	492394	Spring Retainer	1
18	309027	Body, Drain Check	1
* 19	406215	O-Ring, 1/16 x 1/2 x 5/8	1
20	490405	Steel Ball	1
* 21	406518	O-Ring, 3/32 x 9/16 x 3/4	1
22	492395	Spring	1
23	778413	Drain Check Assembly	1
24	406309	Screw, 7/16-14 x 1-3/4	4

\* Included in seal kit #723733 (Viton).

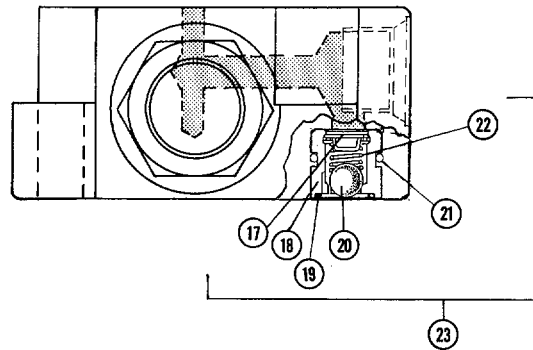

# STANDARD TWO-STAGE COMPENSATOR — SECOND STAGE

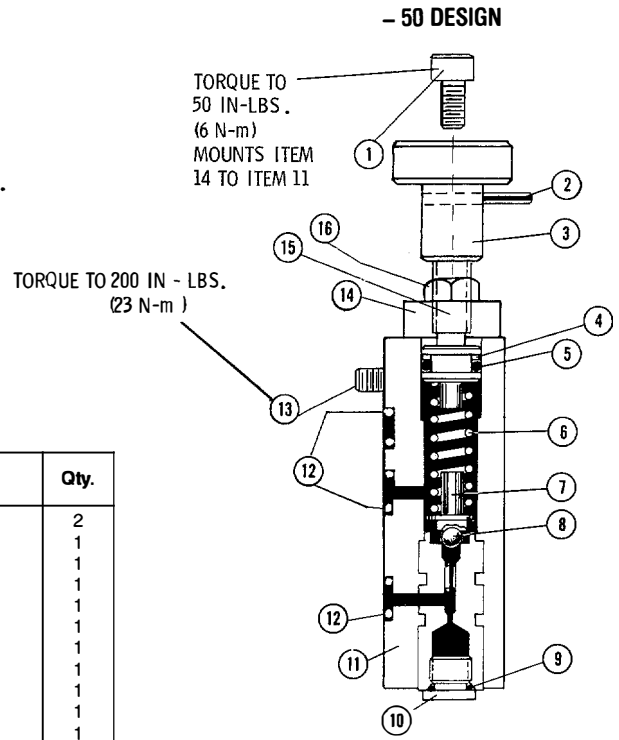
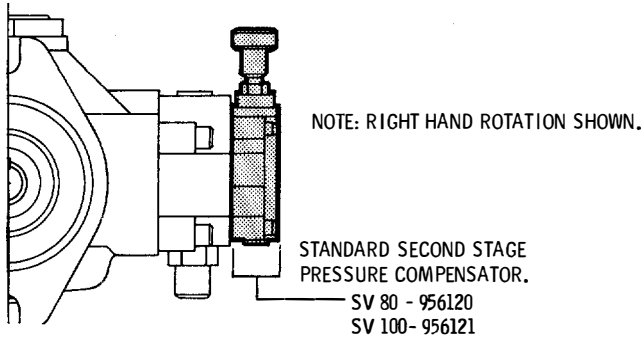

Ref. No.	Part No.	Description	Qty.
1	402396	Screw, #10-24 × 1/2	2
2	401714	Roll Pin	1
3	308730	Knob	1
* 4	490418	Back-Up Ring	1
* 5	406579	O-Ring, 3/32 × 7/16 × 5/8	1
6	406239	Spring (Void)	1
7	308861	Spring Seat (Void)	1
8	492209	Tungsten Carbide Ball (Void)	1
* 9	407141	O-Ring, #4 SAE (-904)	1
10	490708	Plug, #4 SAE	1
11	778313	Body Assembly (-50) (Void)	1
* 12	406797	O-Ring, 1/16 × 5/16 × 7/16	3
13	400779	Screw, 1/4-20 × 1-1/4	3
14	221777	Retaining Cap	1
15	309028	Adjusting Screw	1
16	401011	Lock Nut	1
* 17	492455	O-Ring, 3/32 × 5/16 × 1/2 (-51/61) (Void)	1
18	407846	Spring (-51/52 & -61/62)	1
19	307161	Poppet (-51/61 Only) (Void)	1
20	308012	Seat (-51/61 Only) (Void)	1
* 21	407123	O-Ring, #3 SAE (-903)	1
22	222962	Body (-51/52 & -61/62)	1
23	309057	Poppet (-52/62 Only)	1
24	309058	Seat (-52/62 Only)	1

\* Included in seal kits #723733 (Viton)

- 51 DESIGN  
- 61 DESIGN

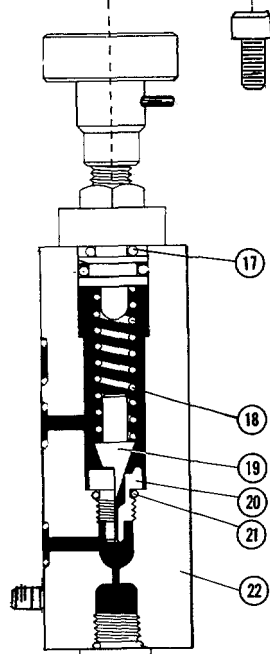

- 52 DESIGN  
- 62 DESIGN

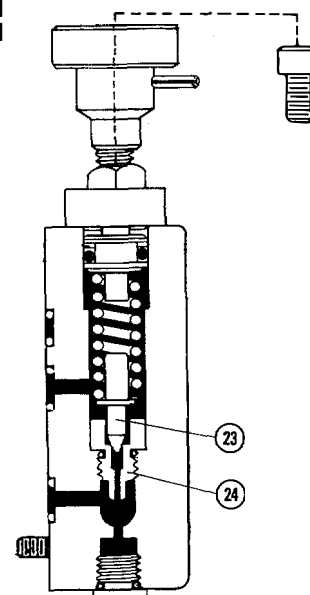

# ADAPTOR/COUPLING SYSTEM

**NOTE:** Coupling system is a "Wet Design". The lead pump does not have a rear shaft seal. This allows the adaptor to fill with fluid to lubricate and cool the coupling.

**\*\*NOTE:** When the weight of the trailing pump(s) exceeds 65 lbs., this part must be used.

**\*NOTE:** Roll pins should be pressed into pump prior to assembly.

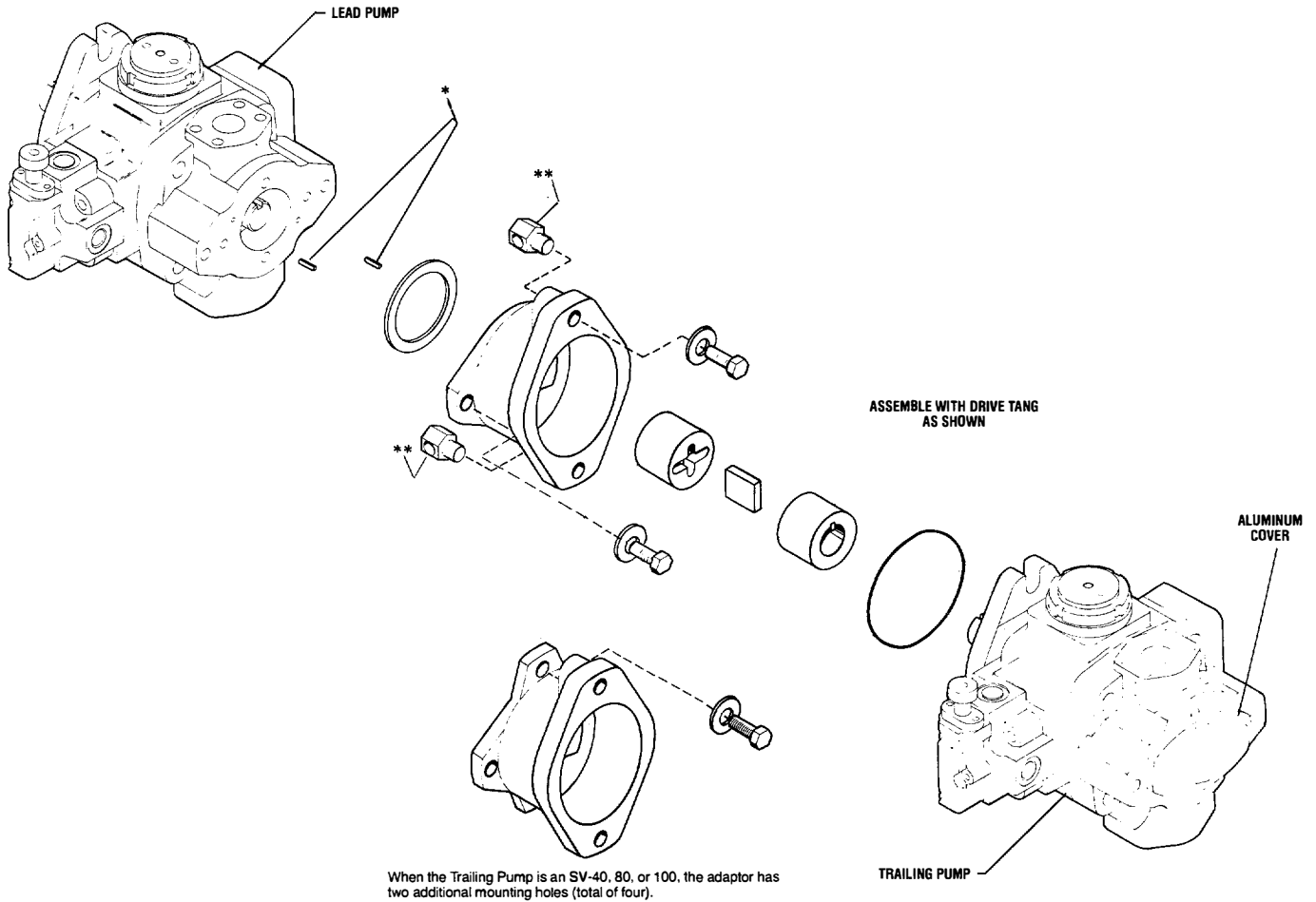

## ADAPTOR KITS

LEAD PUMP	TRAILING PUMP	KIT #
SV80/100	SV10/15 & PSQ	956109
SV80/100	SV20/25	956110
SV80/100	SV40	956106
SV80/100	SV80/100	956105
SV80/100	EO55	956183
SV80/100	20L, 20H	956184
SV80/100	80L, 80M, 80H	956185

For repair parts & engineering data refer to Bulletins 14.60 & A14-62 respectively.

# SUPPORT RODS

Robert Bosch includes support guides in each tandem mounting kit. Because of the varying height differences for each application, it is the customers responsibility to provide the actual support rods and lock nuts. Listed below are the support guide diameters and some mounting requirements.

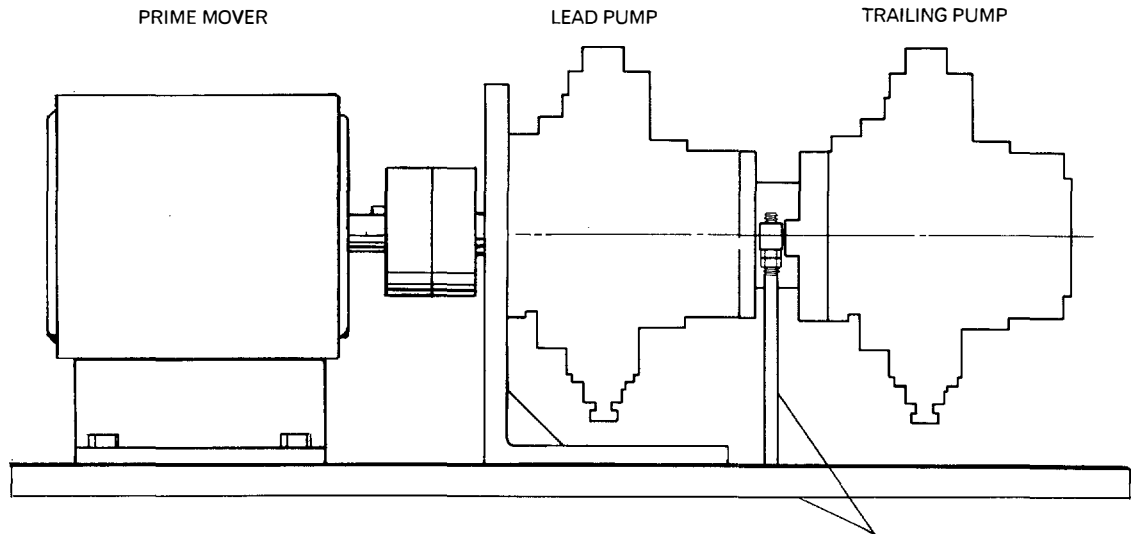

## SUPPORT ROD GUIDE SV80/100

### \*\* IMPORTANT NOTES \*\*

1. Support rods are required when a trailing pump or pumps exceed 65 lbs. in weight.
2. The support rod must be mounted with the bottom of the rod attached to the same mounting surface as the electric motor and pump flange bracket (see above picture).

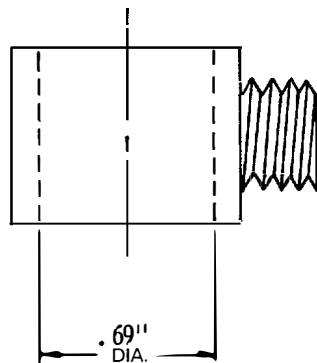

HPUS RSB 003/24 US (12.93)

ROBERT BOSCH FLUID POWER CORPORATION  
P.O. BOX 2025  
RACINE, WISCONSIN 53401-2025 U.S.A.  
Phone (414)554-7100, Fax (414)554-7117

Printed in USA



# BOSCH