

Hydrostatic Pump Repair

www.hydrostaticpumprepair.net

Phone: 800-361-0028

Email: sales@hydrostatic-transmission.com

Rexroth
Bosch Group

Axial Piston Variable Motor A6VM

RE 91610/07.09
Replaces: 03.09

1/80

Data sheet

Series 71
Sizes NG60 to 280
Nominal pressure 450 bar
Maximum pressure 500 bar
Open and closed circuits

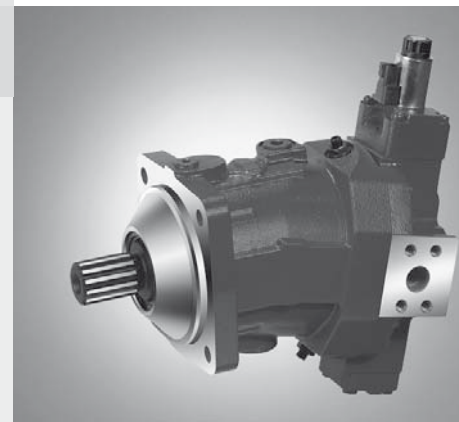

Contents

Ordering code for standard program	3
Technical data	5
HP – Proportional control hydraulic	10
EP – Proportional control electric	13
HZ – Two-point control hydraulic	16
EZ – Two-point control electric	18
HA – Automatic control high-pressure related	20
DA – Automatic control speed related	26
Electric travel direction valve (for DA, HA.R)	28
Dimensions size 60 to 280	30
Connector for solenoids	71
Setting range for displacement	72
Flush and boost pressure valve	73
Sensors	75
Installation instructions	76
General instructions	80

Features

- Variable motor with axial tapered piston rotary group of bent axis design, for hydrostatic drives in open and closed circuit
- For use in mobile and stationary application areas
- The wide control range enables the variable motor to satisfy the requirement for high speed and high torque.
- The displacement can be steplessly changed from $V_{g \max}$ to $V_{g \min} = 0$.
- The output speed is dependent on the flow of the pump and the displacement of the motor.
- The output torque increases with the pressure differential between the high and low pressure sides and with increasing displacement.
- Wide control range with hydrostatic transmissions
- Wide selection of control devices
- Cost savings through elimination of gear shifts and possibility of using smaller pumps
- Compact, robust bearing system with long service life
- High power density
- Good starting characteristics
- Version with 9-piston rotary group
- Good slow-running characteristics
- High uniformity

Ordering code for standard program

A6V	M					0	0			/	71	M	W	V	0						
01	02	03	04	05	06	07	08	09	10		11	12	13	14	15	16	17	18	19	20	21

Axial piston unit

01	Bent axis design, variable, nominal pressure 450 bar, maximum pressure 500 bar	A6V
----	--	------------

Operation mode

02	Motor	M
----	-------	----------

Size

03	≈ Displacement $V_{g \max}$ in cm^3	060	085	115	150	170	215	280
----	--	------------	------------	------------	------------	------------	------------	------------

Control device

		060	085	115	150	170	215	280			
04	Proportional control hydraulic, positive control	$\Delta p_{St} = 10 \text{ bar}$	●	●	●	●	●	●	○	HP1	
		$\Delta p_{St} = 25 \text{ bar}$	●	●	●	●	●	●	○	HP2	
		negative control	$\Delta p_{St} = 10 \text{ bar}$	●	●	●	●	●	●	○	HP5
			$\Delta p_{St} = 25 \text{ bar}$	●	●	●	●	●	●	○	HP6
	electric, positive control	$U = 12 \text{ V DC}$	●	●	●	●	●	●	●	EP1	
		$U = 24 \text{ V DC}$	●	●	●	●	●	●	●	EP2	
		negative control	$U = 12 \text{ V DC}$	●	●	●	●	●	●	●	EP5
			$U = 24 \text{ V DC}$	●	●	●	●	●	●	●	EP6
	Two-point control hydraulic, negative control		-	-	-	●	●	●	○	HZ5	
			●	●	●	-	-	-	-	HZ7	
		electric, negative control	$U = 12 \text{ V DC}$	-	-	-	●	●	●	○	EZ5
			$U = 24 \text{ V DC}$	-	-	-	●	●	●	○	EZ6
Automatic control high-pressure related, positive control	without pressure increase		●	●	●	●	●	○	HA1		
		with pressure increase $\Delta p = 100 \text{ bar}$	●	●	●	●	●	●	○	HA2	
	speed related negative control, $p_{St}/p_{HD} = 5/100$	hydr. travel direction valve	●	●	●	●	●	●	○	DA0	
		electr. travel direction valve $U = 12 \text{ V DC}$	●	●	●	●	●	●	-	DA1	
	+ electr. $V_{g \max}$ -circuit $U = 24 \text{ V DC}$	●	●	●	●	●	●	-	DA2		

Pressure control/override

		060	085	115	150	170	215	280		
05	Without	●	●	●	●	●	●	●	00	
	Pressure control only for HP5, HP6, EP5 and EP6	fixed setting	●	●	●	●	●	●	○	D1
		hydraulic remote control, proportional	●	●	●	●	●	●	○	T3
	Override of HA-control only for HA1, HA2	electric, two-point	$U = 12 \text{ V DC}$	●	●	●	●	●	-	U1
			$U = 24 \text{ V DC}$	●	●	●	●	●	●	-
		electric and travel direction valve, electric	$U = 12 \text{ V DC}$	●	●	●	●	●	●	-
$U = 24 \text{ V DC}$			●	●	●	●	●	●	-	R2

Connector for solenoids¹⁾

		060	085	115	150	170	215	280	
06	Without	●	●	●	●	●	●	●	0
	DEUTSCH - molded connector, 2-pin – without suppressor diode	●	●	●	●	●	●	●	P

● = Available ○ = On request - = Not available

¹⁾ Connectors for other electric components can deviate.

Ordering code for standard program

A6V	M					0	0			/	71	M	W	V	0						
01	02	03	04	05	06	07	08	09	10		11	12	13	14	15	16	17	18	19	20	21

Auxiliary function 1											060	085	115	150	170	215	280	
07	Without										●	●	●	●	●	●	●	0

Auxiliary function 2											060	085	115	150	170	215	280	
08	Without										●	●	●	●	●	●	●	0

Response time damping (for selection, see control)											060	085	115	150	170	215	280	
09	Without damping (standard with HP and EP)										●	●	●	●	●	●	●	0
	With damping (HP, EP, HP5,6D. and EP5,6D.; HZ, EZ)										●	●	●	●	●	●	●	1
	One-sided in inlet to large stroking chamber (HA)										●	●	●	●	●	●	●	4
	One-sided in outlet from large stroking chamber (DA)										●	●	●	●	●	●	●	7

Setting range for displacement²⁾											060	085	115	150	170	215	280	
10	$V_{g \max}$ adjusting screw					$V_{g \min}$ adjusting screw												
	Without (not for size 280)					short (0-adjustable)					●	●	●	●	●	●	-	A
						medium					●	●	●	●	●	●	-	B
	Short					short (0-adjustable)					●	●	●	●	●	●	●	E
					medium					●	●	●	●	●	●	●	F	

Series																			
11	Series 7, Index 1																		71

Version of port and fixing threads																			
12	Metric																		M

Direction of rotation																			
13	Viewed from drive shaft, alternating																		W

Seals																			
14	FKM (fluor-caoutchouc)																		V

Drive shaft bearing											060	085	115	150	170	215	280	
15	Standard bearing										●	●	●	●	●	●	●	0

Mounting flange											060	085	115	150	170	215	280	
16	ISO 3019-2		125-4		●	-	-	-	-	-	-	-	-	M4				
	Metric		140-4		-	●	-	-	-	-	-	-	-	N4				
			160-4		-	-	●	-	-	-	-	-	-	P4				
			180-4		-	-	-	●	●	-	-	-	-	R4				
			200-4		-	-	-	-	-	●	●	-	-	S4				

● = Available ○ = On request - = Not available

2) The adjustment values for the adjusting screws can be found in the table (page 72).

Ordering code for standard program

A6V	M					0	0			/	71	M	W	V	0						
01	02	03	04	05	06	07	08	09	10		11	12	13	14	15	16	17	18	19	20	21

		060	085	115	150	170	215	280	
17	Drive shaft								
	Splined shaft ANSI B92.1a-1976	1 1/4 in 14T 12/24DP	●	-	-	-	-	-	S7
		1 1/2 in 17T 12/24DP	-	●	-	-	-	-	S9
		1 3/4 in 13T 8/16DP	-	-	●	●	-	-	T1
		2 in 15T 8/16DP	-	-	-	○	●	●	T2
		2 1/4 in 17T 8/16DP	-	-	-	-	-	-	●
	Splined shaft DIN 5480	W60x2x28x9g	-	-	-	-	-	●	A4

		060	085	115	150	170	215	280	
18	Port plate for service lines								
	SAE flange ports A and B: rear	●	●	●	●	●	●	●	1
	SAE flange ports A and B: at side, opposite	●	●	●	●	●	●	●	2

		060	085	115	150	170	215	280		
19	Valves									
	Without	●	●	●	●	●	●	●	0	
	With flush and boost pressure valve mounted, flushing on both sides $\Delta p = p_{ND} - p_G = 25 \text{ bar}$ and $v = 10 \text{ mm}^2/\text{s}$ ($p_G = \text{case pressure}$)	flushing flow q_v (L/min) 3.5	●	●	●	-	-	-	-	A
		5	●	●	●	-	-	-	-	B
		8	●	●	●	●	●	●	-	C
		10	●	●	●	●	●	●	-	D
		14	●	●	●	-	-	-	-	F
		17	-	-	-	●	●	●	-	G
		20	-	-	● ³⁾	●	●	●	-	H
		25	-	-	● ³⁾	●	●	●	-	J
		30	-	-	● ³⁾	●	●	●	-	K
		35	-	-	-	●	●	●	-	L
40	-	-	-	●	●	●	-	M		
	adjustable 0 to 60	-	-	-	-	-	-	●	V	

		060	085	115	150	170	215	280	
20	Sensors								
	Without	●	●	●	●	●	●	●	0
	Prepared for speed sensor DSM	●	●	●	●	●	●	-	U
	Speed sensor DSM ⁴⁾ mounted	●	●	●	●	●	●	-	V

		060	085	115	150	170	215	280	
21	Standard / special version								
	Standard version								-0
		with attachment part							-K
	Special version								-S
	with attachment part								-T

Note

Short designation X refers to a special version not covered by the ordering code.

● = Available ○ = On request - = Not available

³⁾ Not for EZ7, 8 and HZ7

⁴⁾ Observe the requirements for the electronics

Technical data

Hydraulic fluid

Before starting project planning, please refer to our data sheets RE 90220 (mineral oil) and RE 90221 (environmentally acceptable hydraulic fluids) for detailed information regarding the choice of hydraulic fluid and application conditions.

The A6VM variable motor is not suitable for operation with HFA. If HFB, HFC and HFD or environmentally acceptable hydraulic fluids are being used, the limitations regarding technical data and seals must be observed.

Please contact us.

When ordering, indicate the hydraulic fluid that is to be used.

Selection diagram

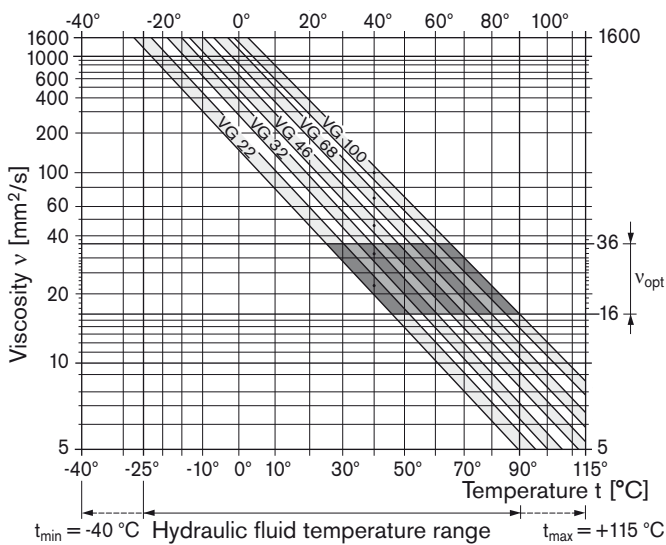

Details regarding the choice of hydraulic fluid

The correct choice of hydraulic fluid requires knowledge of the operating temperature in relation to the ambient temperature: in a closed circuit the circuit temperature; in an open circuit the tank temperature.

The hydraulic fluid should be chosen so that the operating viscosity in the operating temperature range is within the optimum range (v_{opt}), see shaded area of the selection diagram. We recommend that the higher viscosity class be selected in each case.

Example: At an ambient temperature of X °C, an operating temperature of 60 °C is set in the circuit. In the optimum operating viscosity range (v_{opt} , shaded area), this corresponds to the viscosity classes VG 46 or VG 68; to be selected: VG 68.

Note

The case drain temperature, which is affected by pressure and speed, is always higher than the circuit temperature or tank temperature. At no point of the component may the temperature be higher than 115 °C, however. The temperature difference specified below is to be taken into account when determining the viscosity in the bearing.

If the above conditions cannot be maintained due to extreme operating parameters, we recommend flushing the case at port U or using a flush and boost pressure valve (see pages 73 and 74).

Viscosity and temperature

	Viscosity [mm ² /s]	Temperature	Comment
Storage		$T_{min} \geq -50$ °C $T_{opt} = +5$ °C to $+20$ °C	up to 12 months with standard factory conservation up to 24 months with long-term factory conservation
(Cold) start-up ¹⁾	$v_{max} = 1600$	$T_{St} \geq -40$ °C	$t \leq 3$ min, without load ($p \leq 50$ bar), $n \leq 1000$ rpm
Permissible temperature difference		$\Delta T \leq 25$ K	between axial piston unit and hydraulic fluid
Warm-up phase	$v < 1600$ to 400	$T = -40$ °C to -25 °C	at p_{nom} , $0.5 \cdot n_{nom}$ and $t \leq 15$ min
Operating phase			
Temperature difference		$\Delta T = \text{approx. } 12$ K	The temperature of the hydraulic fluid in the bearing is (depending on pressure and speed) approx. 12 K higher than that of the case drain fluid at port T. The bearing temperature can be reduced by flushing via port U.
Continuous operation	$v = 400$ to 10 $v_{opt} = 16$ to 36	$T = -25$ °C to $+90$ °C	no restriction within the permissible data
Short-term operation	$v_{min} = 5$	$T_{max} = +115$ °C	$t < 3$ min, $p < 0.3 \cdot p_{nom}$
Shaft seal ring FKM ¹⁾		$T \leq +115$ °C	See page 6

1) At temperatures below -25 °C, an NBR shaft seal ring is required (permissible temperature range: -40 °C to $+90$ °C)

Technical data

Filtration of the hydraulic fluid

Filtration improves the cleanliness level of the hydraulic fluid, which, in turn, increases the service life of the axial piston unit.

To ensure the functional reliability of the axial piston unit, a gravimetric evaluation is necessary for the hydraulic fluid to determine the amount of contamination by solid matter and to determine the cleanliness level according to ISO 4406. A cleanliness level of at least 20/18/15 is to be maintained.

At very high hydraulic fluid temperatures (90 °C to maximum 115 °C), a cleanliness level of at least 19/17/14 according to ISO 4406 is necessary.

If the above classes cannot be achieved, please contact us.

Shaft seal ring

Permissible pressure loading

The service life of the shaft seal ring is affected by the speed of the motor and the case drain pressure. It is recommended that the average, continuous case drain pressure 3 bar absolute at operating temperature not be exceeded (maximum permissible case drain pressure 6 bar absolute at reduced speed, see diagram). Short-term ($t < 0.1$ s) pressure spikes of up to 10 bar absolute are permitted. The service life of the shaft seal ring decreases with an increase in the frequency of pressure spikes.

The case pressure must be equal to or greater than the external pressure on the shaft seal ring.

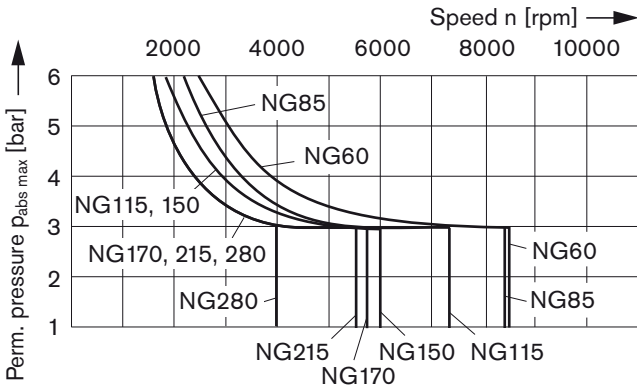

Temperature range

The FKM shaft seal ring may be used for case drain temperatures from -25 °C to +115 °C.

Note

For application cases below -25 °C, an NBR shaft seal ring is necessary (permissible temperature range: -40 °C to +90 °C). State NBR shaft seal ring in plain text when ordering. Please contact us.

Effect of case pressure on start of control

An increase in the case pressure has an effect on the following controls when control of the variable motor begins:

HP, HA.T3 _____ increase
 DA _____ decrease

With the following controls, an increase in the case pressure has no influence on the start of control:
 HA.R and HA.U (NG60 to 215), EP, HA

The factory adjustment of the start of control is made at $p_{abs} = 2$ bar case pressure.

Flow direction

Direction of rotation, viewed from drive shaft	
clockwise	counter-clockwise
A to B	B to A

Speed range

$\Delta p = 100$ bar, $\Delta n = \pm 20$ % _____ $n_{min} = 20$ rpm.

$\Delta p = 200$ bar, $\Delta n = \pm 20$ % _____ $n_{min} = 45$ rpm.

See table of values on page 8 for maximum speed.

Technical data

Operating pressure range

Pressure at service line port A or B

Nominal pressure p_{nom} _____ 450 bar absolute

Maximum pressure p_{max} _____ 500 bar absolute

Single operating period _____ 10 s

Total operating period _____ 300 h

Minimum pressure (high-pressure side) _____ 25 bar

Total pressure (pressure A + pressure B) p_{Su} _____ 700 bar

Rate of pressure change $R_{A\ max}$

with integrated pressure-relief valve _____ 9000 bar/s

without pressure-relief valve _____ 16000 bar/s

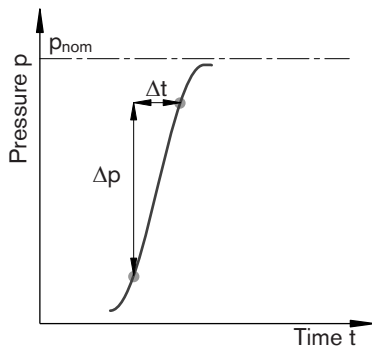

Minimum pressure (inlet)

In order to avoid damage to the axial piston unit, a minimum pressure must be ensured at the service line port (inlet). The minimum pressure is dependent on the speed and displacement of the axial piston unit.

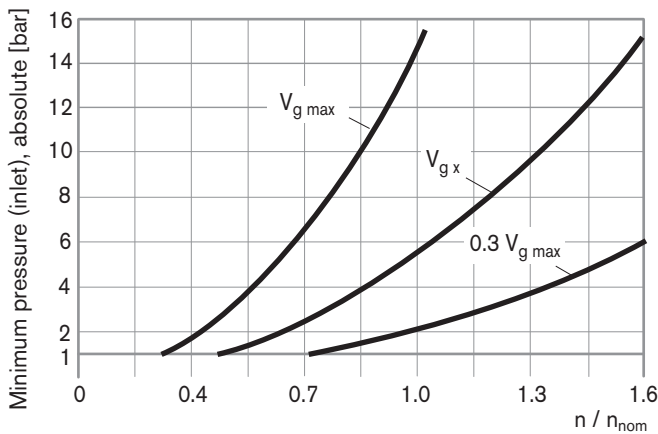

Please contact us if these conditions cannot be satisfied.

Definition

Nominal pressure p_{nom}

The nominal pressure corresponds to the maximum design pressure.

Maximum pressure p_{max}

The maximum pressure corresponds to the maximum operating pressure within the single operating period. The sum of the single operating periods must not exceed the total operating period.

Minimum pressure (high-pressure side)

Minimum pressure on the high-pressure side (A or B) that is required in order to prevent damage to the axial piston unit.

Total pressure p_{Su}

The total pressure is the sum of the pressures at the ports for the service lines.

Rate of pressure change R_A

Maximum permissible rate of pressure build-up and pressure reduction during a pressure change over the entire pressure range.

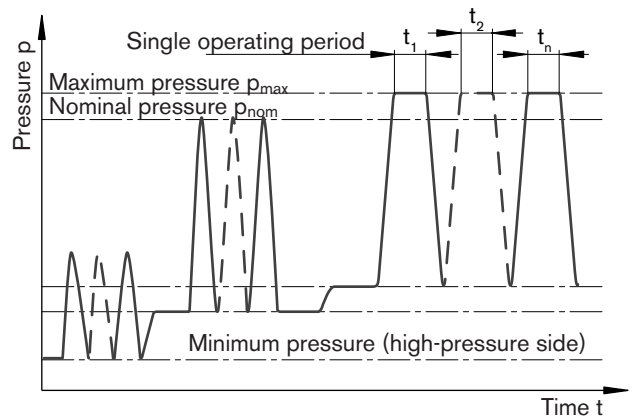

$$\text{Total operating period} = t_1 + t_2 + \dots + t_n$$

Technical data

Table of values (theoretical values, without efficiency levels and tolerances; values rounded)

Size	NG		60	85	115	150	170	215	280
Displacement	$V_{g \max}$	cm ³	62.0	85.2	115.6	152.1	171.8	216.5	280.1
	$V_{g \min}$	cm ³	0	0	0	0	0	0	0
Speed (while adhering to the maximum permissible flow)	n_{nom} at $V_{g \max}$	rpm	4450	3900	3550	3250	3100	2900	2500
	n_{max} at $V_g < V_{g x}$	rpm	7200	6800	6150	5600	5150	4800	4000
	$V_{g x} \approx 0.6 \cdot V_{g \max}$	cm ³	37	51	69	91	103	130	175
	n_{max} at $V_{g \min}$	rpm	8400	8350	7350	6000	5750	5500	4000
Flow at $V_{g \max}$ and n_{nom}	$q_{V \max}$	l/min	276	332	410	494	533	628	700
Torque at $V_{g \max}$ and $\Delta p = 450$ bar	T_{\max}	Nm	444	610	828	1089	1230	1550	2006
Rotary stiffness $V_{g \max}$ to $V_g/2$	c_{\min}	Nm/rad	14500	22400	37300	43500	51900	69600	71800
	$V_g/2$ to 0 (interpolated)	c_{\max}	Nm/rad	45300	67500	103800	124000	156400	195600
Moment of inertia for rotary group	J_{GR}	kgm ²	0.0043	0.0072	0.0110	0.0181	0.0213	0.0303	0.0479
Maximum angular acceleration	α	rad/s ²	21000	17500	15500	11000	11000	10000	7000
Filling capacity	V	L	0.8	1.0	1.5	1.7	2.3	2.8	3.4
Mass (approx.)	m	kg	28	36	46	61	62	78	101

Note

Operation above the maximum values or below the minimum values may result in a loss of function, a reduced service life or in the destruction of the axial piston unit. Other permissible limit values with respect to speed variation, reduced angular acceleration as a function of the frequency and the permissible startup angular acceleration (lower than the maximum angular acceleration) can be found in data sheet RE 90261.

Permissible displacement in relation to speed

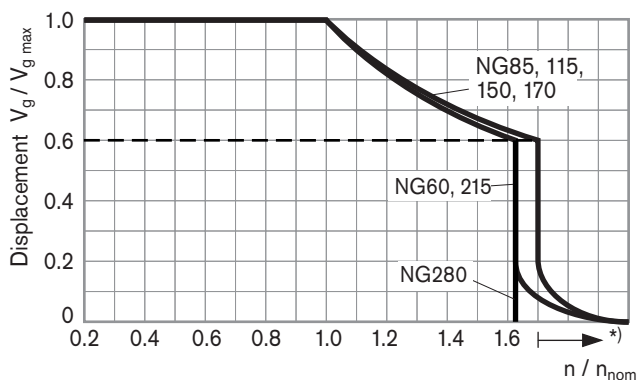



*) approx. values, values on request

Technical data

Permissible radial and axial loading on drive shaft

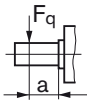
The specified values are maximum values and do not apply to continuous operation.

Size	NG		60	85	115	150	150	170	215	280	280	
Drive shaft		in	1 1/4	1 1/2	1 3/4	1 3/4	2	2	2	2 1/4	W60	
Radial force, maximum ¹⁾ at distance a (from shaft collar)		$F_{q \max}$	N	7620	12463	15948	15948	23200	22602	22602	27997	36000
		a	mm	24.0	27.0	33.5	33.5	33.5	33.5	33.5	40	40
Permissible nominal pressure at $V_{g \max}$		$p_{\text{nom perm.}}$	bar	315	440	450	370	450	450	420	450	450
Permissible torque		T_{\max}	Nm	310	595	828	890	1089	1230	1445	2006	2006
Axial force, maximum ²⁾		$+F_{ax \max}$	N	500	710	900	1030	1030	1120	1250	1575	1575
		$-F_{ax \max}$	N	0	0	0	0	0	0	0	03 ³⁾	03 ³⁾
Permissible axial force per bar operating pressure		$F_{ax \text{ perm./bar}}$	N/bar	7.5	9.6	11.3	13.3	13.3	15.1	17.0	19.4	19.4

1) With intermittent operation.

2) Maximum permissible axial force during standstill or when the axial piston unit is operating in non-pressurized condition.

3) Please contact us.

Note

Force-transfer direction of the permissible axial force:

+ $F_{ax \max}$ = Increase in service life of bearings

- $F_{ax \max}$ = Reduction in service life of bearings (avoid)

Effect of radial force F on the service life of bearings

By selecting a suitable force-transfer direction of F_q , the stress on the bearings caused by the internal transmission forces can be reduced, thus achieving the optimum service life of the bearings. Recommended position of mating gear is dependent on direction of rotation. Examples:

Toothed gear drive

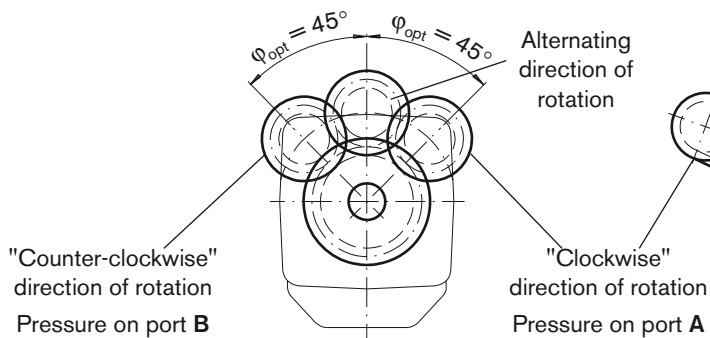

V-belt drive

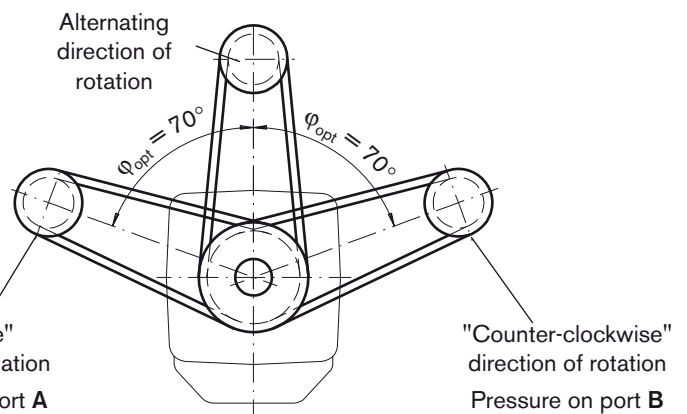

Determining the size

$$\text{Flow } q_v = \frac{V_g \cdot n}{1000 \cdot \eta_v} \quad [\text{L/min}]$$

$$\text{Speed } n = \frac{q_v \cdot 1000 \cdot \eta_v}{V_g} \quad [\text{rpm}]$$

$$\text{Torque } T = \frac{V_g \cdot \Delta p \cdot \eta_{mh}}{20 \cdot \pi} \quad [\text{Nm}]$$

$$\text{Power } P = \frac{2 \pi \cdot T \cdot n}{60000} = \frac{q_v \cdot \Delta p \cdot \eta_t}{600} \quad [\text{kW}]$$

V_g = Displacement per revolution in cm^3

Δp = Differential pressure in bar

n = Speed in rpm

η_v = Volumetric efficiency

η_{mh} = Mechanical-hydraulic efficiency

η_t = Total efficiency ($\eta_t = \eta_v \cdot \eta_{mh}$)

HP – Proportional control hydraulic

The pilot-pressure related hydraulic proportional control enables the stepless adjustment of the displacement according to the pilot-pressure signal. The control is proportional to the pilot pressure applied to port X.

HP1, HP2 positive control (— — —)

- Start of control at $V_{g\ min}$ (minimum torque, maximum permissible speed)
- End of control at $V_{g\ max}$ (maximum torque, minimum speed)

HP5, HP6 negative control (————)

- Start of control at $V_{g\ max}$ (maximum torque, minimum speed)
- End of control at $V_{g\ min}$ (minimum torque, maximum permissible speed)

Note

- Maximum permissible pilot pressure: $p_{St} = 100\ \text{bar}$
- For reliable control, an operating pressure of at least 30 bar is required in A (B). If a control operation is required at an operating pressure $< 30\ \text{bar}$, an auxiliary pressure of at least 30 bar is to be applied at port G via an external check valve. For lower pressures, please contact us. Please note that up to 500 bar may be present at port G.
- Please state the desired start of control in plain text when ordering, e.g.: start of control at 10 bar.
- The start of control and the HP characteristic are influenced by the case pressure. An increase in the case pressure causes an increase in the start of control (see page 6) and thus a parallel displacement of the characteristic.

HP1, HP5 pilot pressure increase $\Delta p_{St} = 10\ \text{bar}$

HP1 positive control

A pilot pressure increase of 10 bar at port X results in an increase in displacement from $V_{g\ min}$ to $V_{g\ max}$.

HP5 negative control

A pilot pressure increase of 10 bar at port X results in a decrease in displacement from $V_{g\ max}$ to $V_{g\ min}$.

Start of control, setting range _____ 2 to 20 bar

Standard adjustment:

start of control at 3 bar (end of control at 13 bar)

Note

The spring return feature in the control unit is not a safety device

The spool valve inside the control unit can get stuck in an undefined position by internal contamination (contaminated hydraulic fluid, abrasion or residual contamination from system components). As a result, the axial piston unit can no longer supply the flow specified by the operator.

Check whether your application requires that remedial measures be taken on your machine in order to bring the driven consumer into a safe position (e. g. immediate stop).

Characteristic HP1/HP5

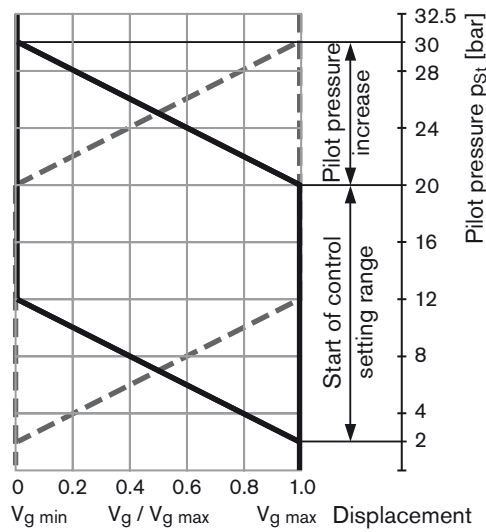

HP2, HP6 pilot pressure increase $\Delta p_{St} = 25\ \text{bar}$

HP2 positive control

A pilot pressure increase of 25 bar at port X results in an increase in displacement from $V_{g\ min}$ to $V_{g\ max}$.

HP6 negative control

A pilot pressure increase of 25 bar at port X results in a decrease in displacement from $V_{g\ max}$ to $V_{g\ min}$.

Start of control, setting range _____ 5 to 50 bar

Standard adjustment:

start of control at 10 bar (end of control at 35 bar)

Characteristic HP2/HP6

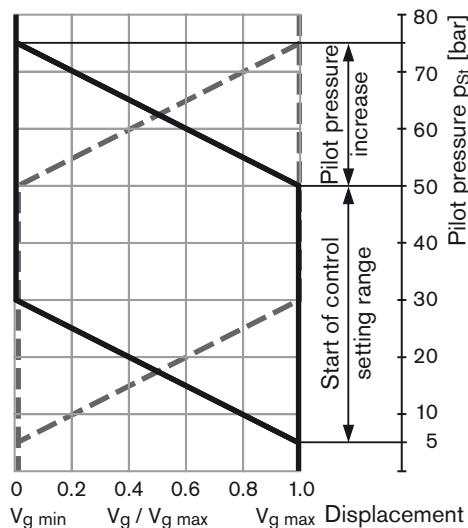

HP – Proportional control hydraulic

Circuit diagram HP1, HP2: positive control
 Sizes 60 to 215

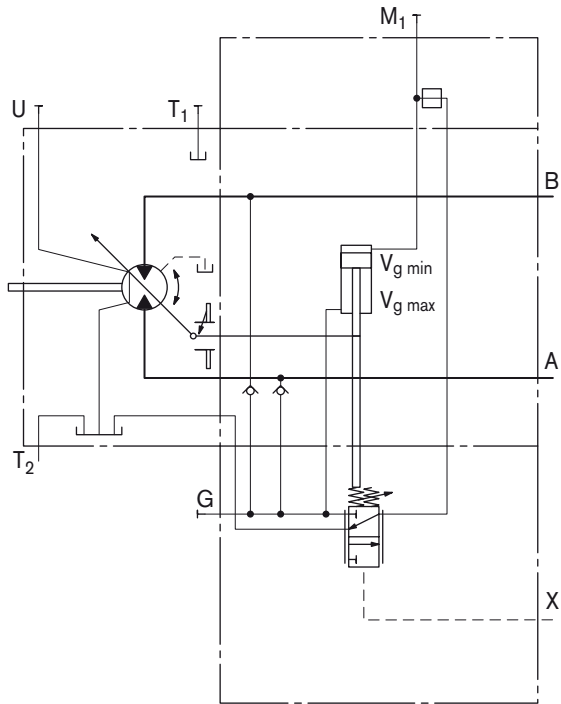

Circuit diagram HP5, HP6: negative control
 Sizes 60 to 215

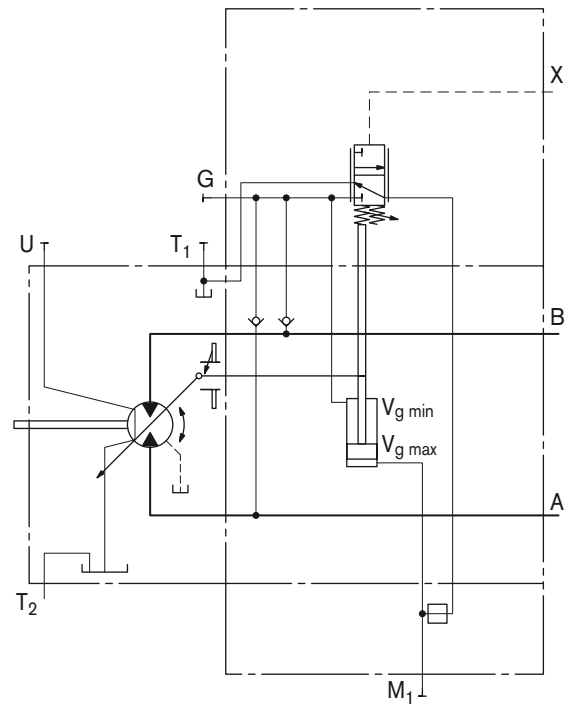

HP – Proportional control hydraulic

HP5D1, HP6D1

Pressure control, fixed setting

The pressure control overlays the HP function. If the load torque or a reduction in the swivel angle of the motor causes the system pressure to increase, the motor will start to swivel to a greater angle when the pressure reaches the setpoint value of the pressure control.

The increase in the displacement and the resulting reduction in pressure cause the control deviation to decrease. With the increase in displacement, the motor develops more torque, while the pressure remains constant.

Setting range on the pressure control valve ____ 80 to 450 bar

Circuit diagram HP5D1, HP6D1: negative control
Sizes 60 to 215

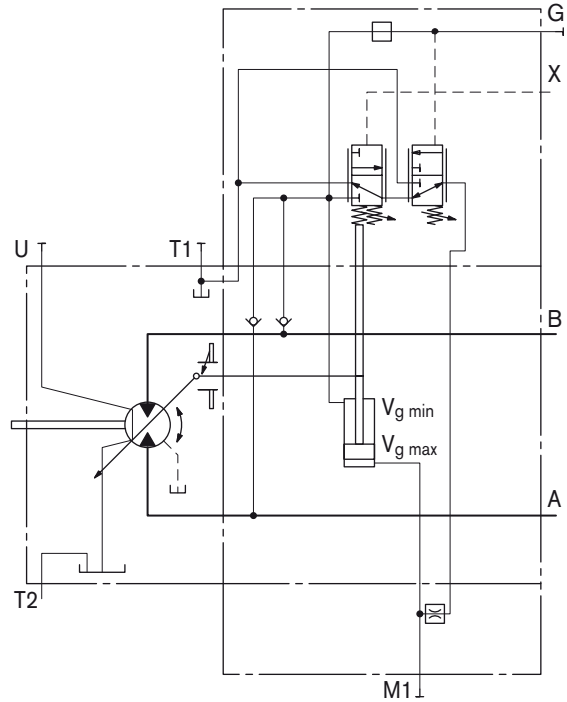

Response time damping

Standard with HP1, HP2 _____ without damping

HP, HP5D1, HP6D1 – with throttle pin symmetrical on both sides

HP – with orifice for NG280

		Size						
		60	85	115	150	170	215	280
1	Groove size	0.45	0.45	0.55	0.55	0.55	0.65	Ø1.2
	Material number	R909411019	R909411019	R909410814	R909410814	R909410814	R909410142	R910912082

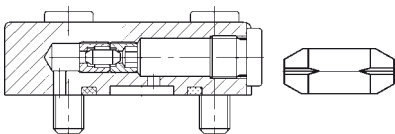

EP – Proportional control electric

The electric proportional control with solenoid enables the stepless adjustment of the displacement as a function of the electric signal. The control is proportional to the applied electric control current.

EP1, EP2 positive control (— — —)

- Start of control at $V_{g \min}$ (minimum torque, maximum permissible speed)
- End of control at $V_{g \max}$ (maximum torque, minimum speed)

EP5, EP6 negative control (———)

- Start of control at $V_{g \max}$ (maximum torque, minimum speed)
- End of control at $V_{g \min}$ (minimum torque, maximum permissible speed)

Characteristic EP1/EP5, EP2/EP6

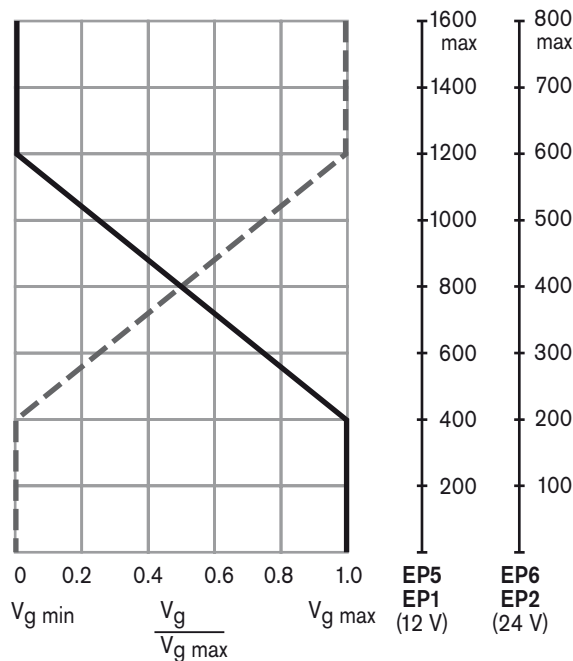

Note

For reliable control, an operating pressure of at least 30 bar is required in A (B). If a control operation is required at an operating pressure < 30 bar, an auxiliary pressure of at least 30 bar is to be applied at port G via an external check valve. For lower pressures, please contact us.

Please note that up to 500 bar may be present at port G.

Technical data, solenoid	EP1, EP5	EP2, EP6
Voltage	12 V ($\pm 20\%$)	24 V ($\pm 20\%$)
Start of control	400 mA	200 mA
End of control	1200 mA	600 mA
Limiting current	1.54 A	0.77 A
Nominal resistance (at 20 °C)	5.5 Ω	22.7 Ω
Dither frequency	100 Hz	100 Hz
Actuated time	100 %	100 %
Type of protection see connector design, page 71		

The following electronic controllers and amplifiers are available for controlling the proportional solenoids:

- BODAS controller RC
 - Series 20 _____ RE 95200
 - Series 21 _____ RE 95201
 - Series 22 _____ RE 95202
 - Series 30 _____ RE 95203
 and application software
- Analog amplifier RA (RE 95230)
- Electric amplifier VT 2000, series 5X (see RE 29904) (for stationary application)

Further information can also be found on the Internet at www.boschrexroth.com/mobile-electronics

Note

The spring return feature in the control unit is not a safety device

The spool valve inside the control unit can get stuck in an undefined position by internal contamination (contaminated hydraulic fluid, abrasion or residual contamination from system components). As a result, the axial piston unit can no longer supply the flow specified by the operator.

Check whether your application requires that remedial measures be taken on your machine in order to bring the driven consumer into a safe position (e. g. immediate stop).

EP – Proportional control electric

Circuit diagram EP1, EP2: positive control
 Sizes 60 to 215

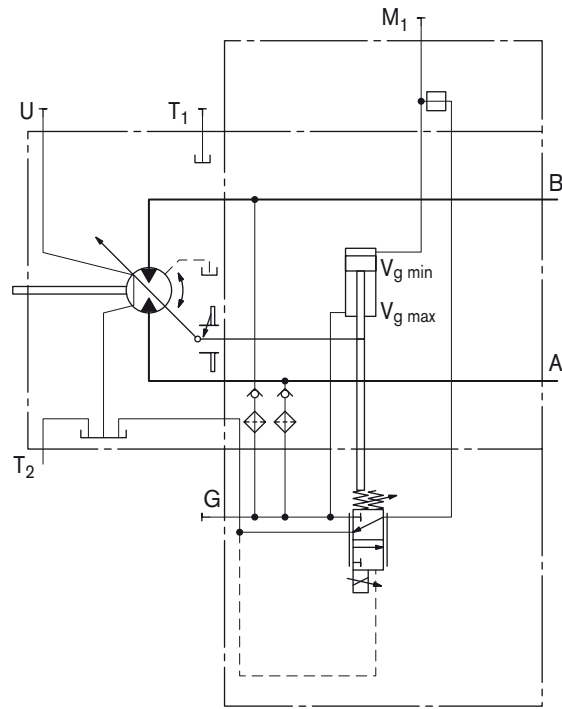

Circuit diagram EP5, EP6: negative control
 Sizes 60 to 215

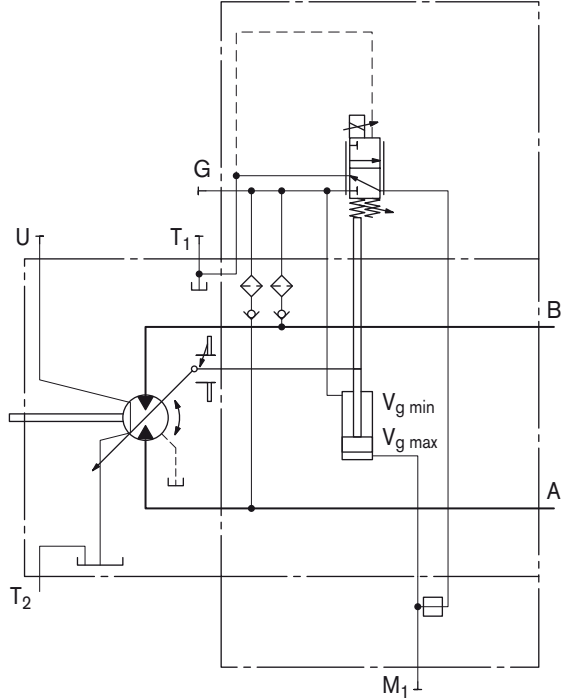

Circuit diagram EP1, EP2: positive control
 Size 280

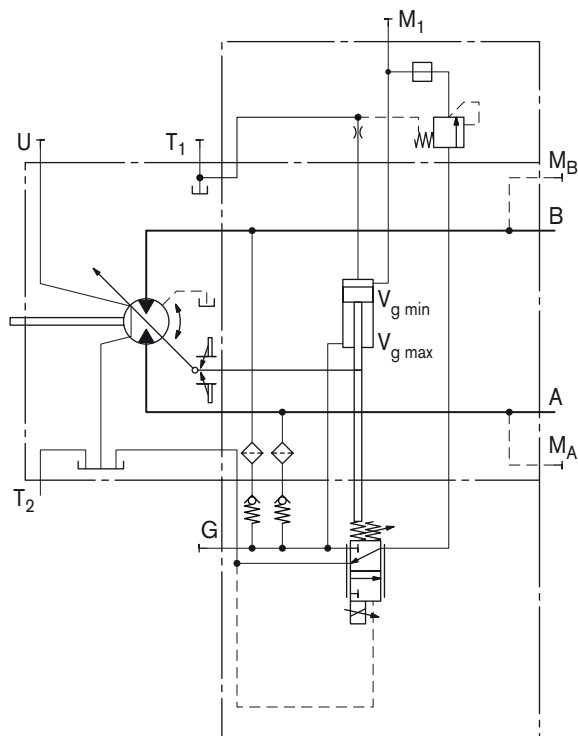

Circuit diagram EP1, EP2: positive control
 Size 280

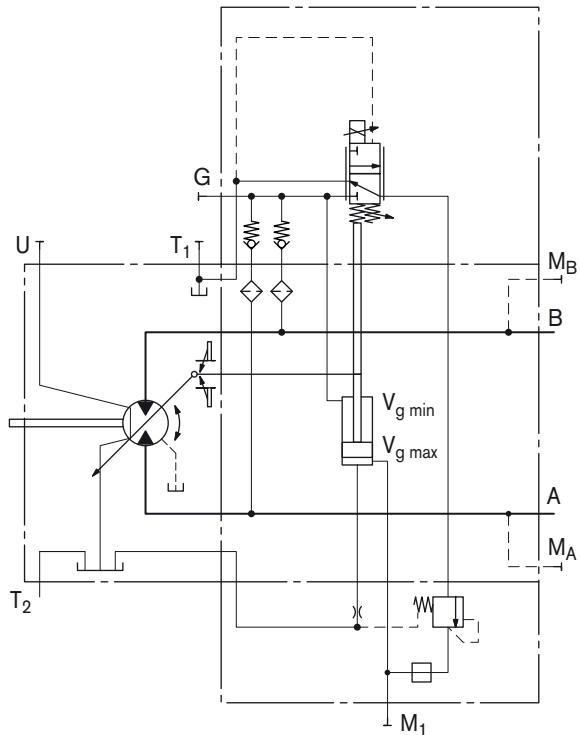

EP – Proportional control electric

EP5D1, EP6D1

Pressure control, fixed setting

The pressure control overlays the EP function. If the load torque increases or a reduction in the swivel angle of the motor causes the system pressure to increase, the motor will start to swivel to a greater angle when the pressure reaches the setpoint value of the pressure control.

The increase in the displacement and the resulting reduction in pressure cause the control deviation to decrease. With the increase in displacement the motor develops more torque, while the pressure remains constant.

Setting range on the pressure control valve ____ 80 to 450 bar

Circuit diagram EP5D1, EP6D1: negative control

Sizes 60 to 215

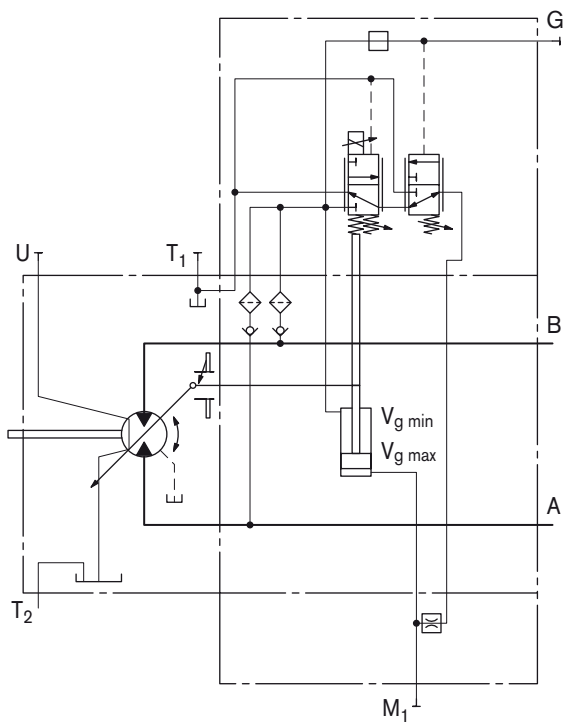

Response time damping

Standard with EP1, EP2 _____ without damping

EP, EP5D1, EP6D1 – with throttle pin symmetrical on both sides

EP – with orifice on NG280

		Size						
		60	85	115	150	170	215	280
1	Groove size	0.45	0.45	0.55	0.55	0.55	0.65	Ø1.2
	Material number	R909411019	R909411019	R909410814	R909410814	R909410814	R909410142	R910912082

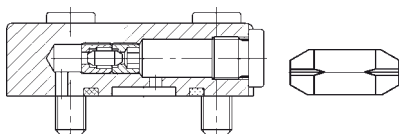

HZ – Two-point control hydraulic

Hydraulic two-point control allows the displacement to be set to $V_{g \min}$ or $V_{g \max}$ by switching the pilot pressure at port X on or off.

No pilot pressure _____ $\hat{=}$ position at $V_{g \max}$

Pilot pressure switched (> 10 bar) _____ $\hat{=}$ position at $V_{g \min}$

HZ5, HZ7 negative control (————)

Start of control at $V_{g \max}$ (maximum torque, minimum speed)

End of control at $V_{g \min}$ (minimum torque, maximum permissible speed)

Characteristic HZ5, HZ7

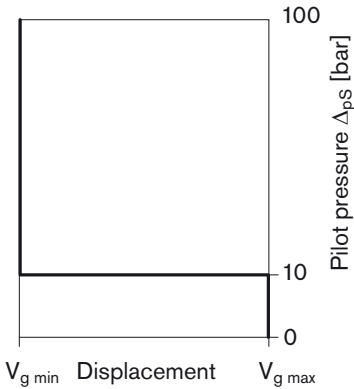

Note

- Maximum permissible pilot pressure: 100 bar
- For reliable control, an operating pressure of at least 30 bar is required in A (B). If a control operation is required at an operating pressure < 30 bar, an auxiliary pressure of at least 30 bar is to be applied at port G via an external check valve. For lower pressures, please contact us.
- Please note that up to 500 bar may be present at port G.

Circuit diagram HZ5: negative control

Sizes 150 to 215

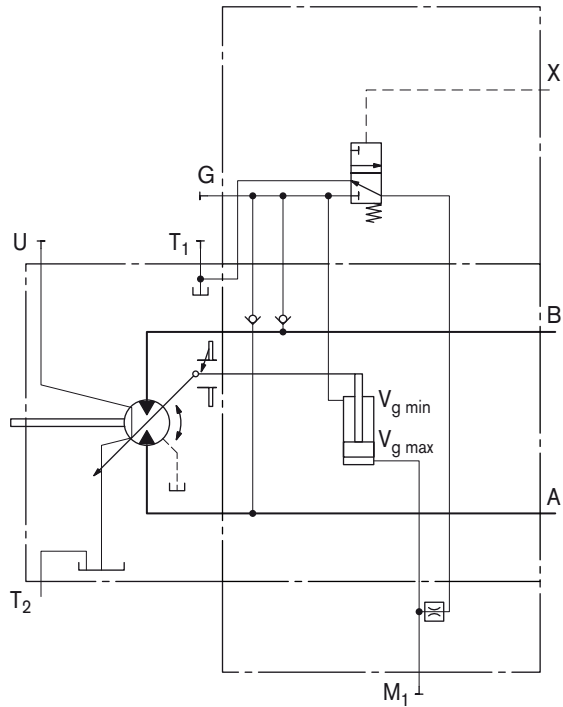

Circuit diagram HZ7: negative control

Sizes 60 to 115

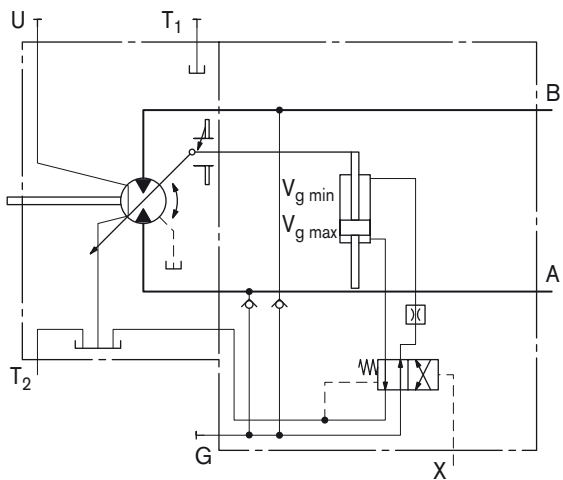

HZ – Two-point control hydraulic

Response time damping

HZ5 – with throttle pin symmetrical on both sides

		Size			
		150	170	215	280
1	Groove size	0.55	0.55	0.65	Ø1.2
	Material number	R909410814	R909410814	R909410142	R910912082

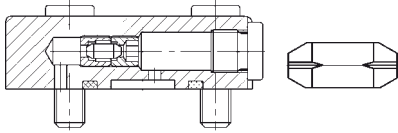

HZ7 – with throttle pin symmetrical on both sides

		Size		
		60	85	115
1	Groove size	0.30	0.30	0.30
	Material number	R909400262	R909400262	R909400262

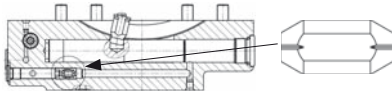

EZ – Two-point control electric

Electric two-point control allows the displacement to be set to $V_{g \min}$ or $V_{g \max}$ by switching the electric current at the switching solenoid on or off.

Note

For reliable control, an operating pressure of at least 30 bar is required in A (B). If a control operation is required at an operating pressure < 30 bar, an auxiliary pressure of at least 30 bar is to be applied at port G via an external check valve. For lower pressures, please contact us. Please note that up to 500 bar may be present at port G.

Technical data, solenoid for EZ5, EZ6 with Ø37 (sizes 150 to 280)	EZ5	EZ6
Voltage	12 V (±20 %)	24 V (±20 %)
Position $V_{g \max}$	de-energized	de-energized
Position $V_{g \min}$	current energized	current energized
Nominal resistance (at 20 °C)	5.5 Ω	21.7 Ω
Nominal power	26.2 W	26.5 W
Active current, min. required	1.32 A	0.67 A
Actuated time	100 %	100 %
Type of protection see connector design, page 71		

Circuit diagram EZ5, EZ6: negative control
 Sizes 150 to 215

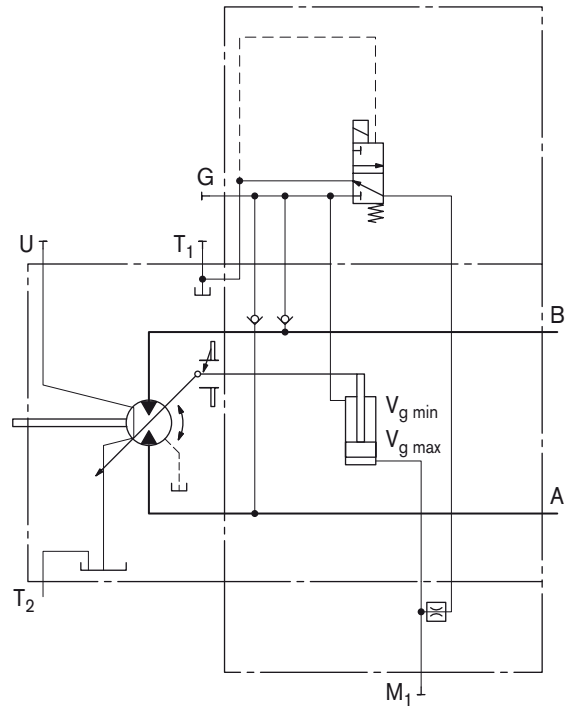

Technical data, solenoid for EZ7, EZ8 with Ø45 (sizes 60 to 115)	EZ7	EZ8
Voltage	12 V (±20 %)	24 V (±20 %)
Position $V_{g \max}$	de-energized	de-energized
Position $V_{g \min}$	current energized	current energized
Nominal resistance (at 20 °C)	4.8 Ω	19.2 Ω
Nominal power	30 W	30W
Active current, min. required	1.5 A	0.75 A
Actuated time	100 %	100 %
Type of protection see connector design, page 71		

Circuit diagram EZ7, EZ8: negative control
 Sizes 60 to 115

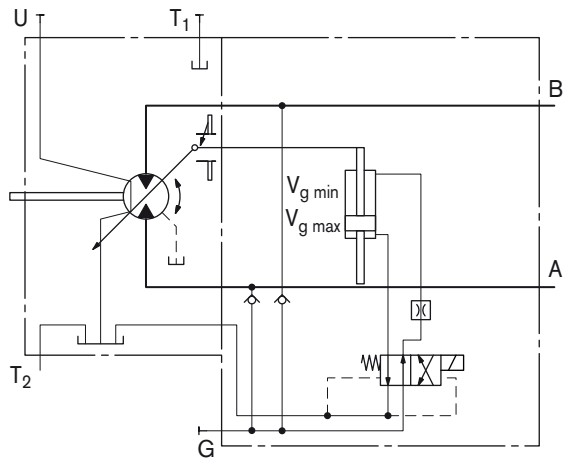

EZ – Two-point control electric

Response time damping

EZ5, EZ6 – with throttle pin symmetrical on both sides

		Size			
		150	170	215	280
1	Groove size	0.55	0.55	0.65	Ø1.2
	Material number	R909410814	R909410814	R909410142	R910912082

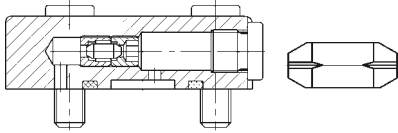

EZ7, EZ8 – with throttle pin symmetrical on both sides

		Size		
		60	85	115
1	Groove size	0.30	0.30	0.30
	Material number	R909400262	R909400262	R909400262

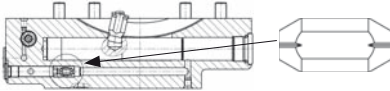

HA – Automatic control high-pressure related

With the automatic high-pressure related control, the motor displacement is adjusted automatically depending on the operating pressure.

The control unit internally measures the operating pressure at A or B (no control line required) and, when the pressure reaches the set pressure value, the controller swivels the motor with increasing operating pressure from $V_{g \min}$ to $V_{g \max}$.

HA1, HA2 positive control

- Start of control at $V_{g \min}$ (minimum torque, maximum speed)
- End of control at $V_{g \max}$ (maximum torque, minimum speed)

Note

- For safety reasons, winch drives are not permissible with start of control at $V_{g \min}$ (standard for HA).
- For reliable control, an operating pressure of at least 30 bar is required in A (B). If a control operation is required at an operating pressure < 30 bar, an auxiliary pressure of at least 30 bar is to be applied at port G via an external check valve. For lower pressures, please contact us. Please note that up to 500 bar may be present at port G.
- The start of control and the HA.T3 characteristic are influenced by the case pressure. An increase in the case pressure causes an increase in the start of control (see page 6) and thus a parallel displacement of the characteristic.

Response time damping

HA – with one-sided throttle pin – inlet to large stroking chamber

		Size						
		60	85	115	150	170	215	280
1	Groove size	0.45	0.45	0.55	0.55	0.55	0.65	-
	Material number	R909425867	R909425867	R909425868	R909425868	R909425868	R909425869	-

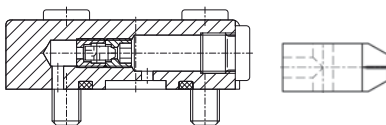

HA – Automatic control high-pressure related

HA1 Approximate without pressure increase, positive control

An operating pressure increase of $\Delta p \leq 10$ bar results in an increase in displacement from $V_{g \min}$ to $V_{g \max}$.

Start of control, setting range _____ 80 to 350 bar

Please state the desired start of control in plain text when ordering, e.g.: start of control at 300 bar

Characteristic HA1

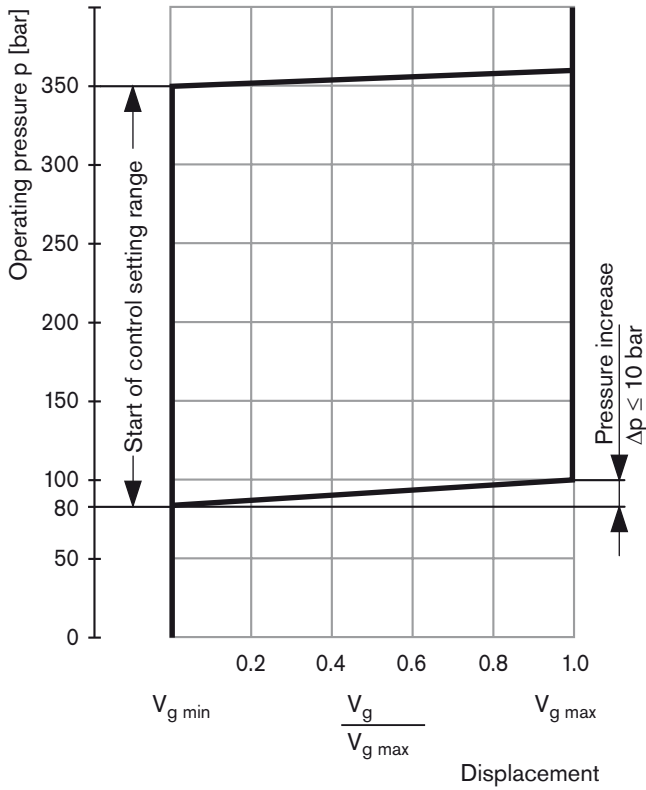

Circuit diagram HA1
Sizes 60 to 215

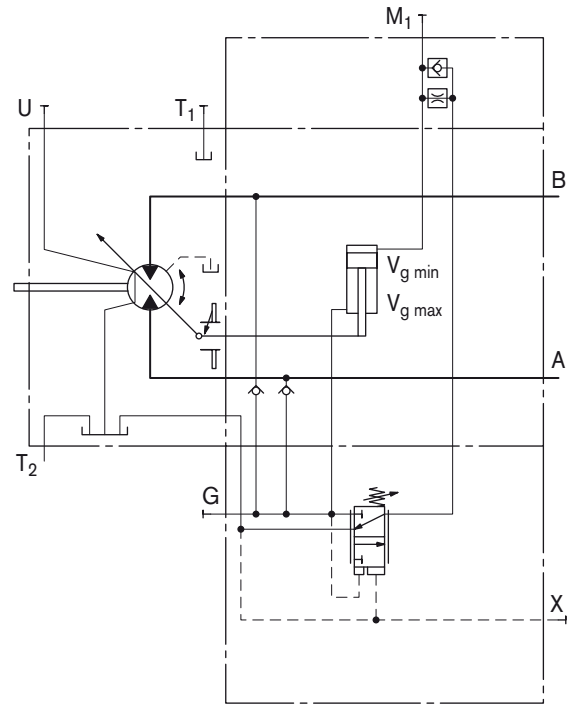

HA – Automatic control high-pressure related

HA2 With pressure increase, positive control

An operating pressure increase of $\Delta p = 100$ bar results in an increase in displacement from $V_{g \min}$ to $V_{g \max}$.

Start of control, setting range
 Sizes 60 to 280 (——) _____ 80 to 350 bar

Please state the desired start of control in plain text when ordering, e. g.: start of control at 200 bar

Characteristic HA2

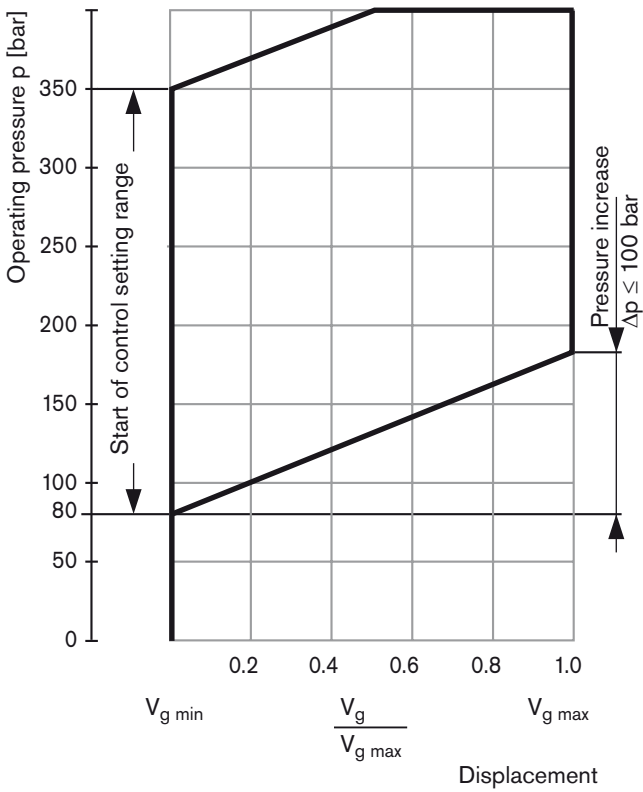

Circuit diagram HA2 Sizes 60 to 215

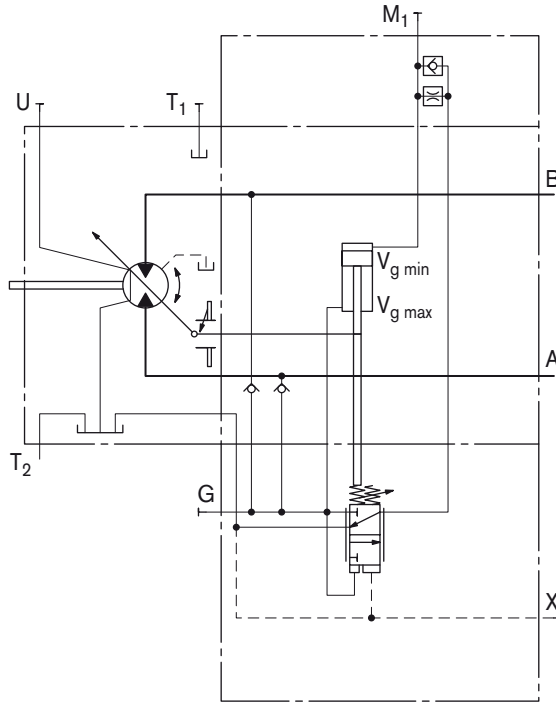

HA – Automatic control high-pressure related

HA.T3 Override, hydraulic remote control, proportional

With the HA.T3 control, the start of control can be influenced by applying a pilot pressure to port X.

For each 1 bar of pilot pressure, the start of control is reduced by 17 bar.

Examples

Start of control adjustment	300 bar	300 bar
Pilot pressure at port X	0 bar	10 bar
Start of control at	300 bar	130 bar

Note

Maximum permissible pilot pressure 100 bar.

Circuit diagram HA1.T3

Sizes 60 to 215

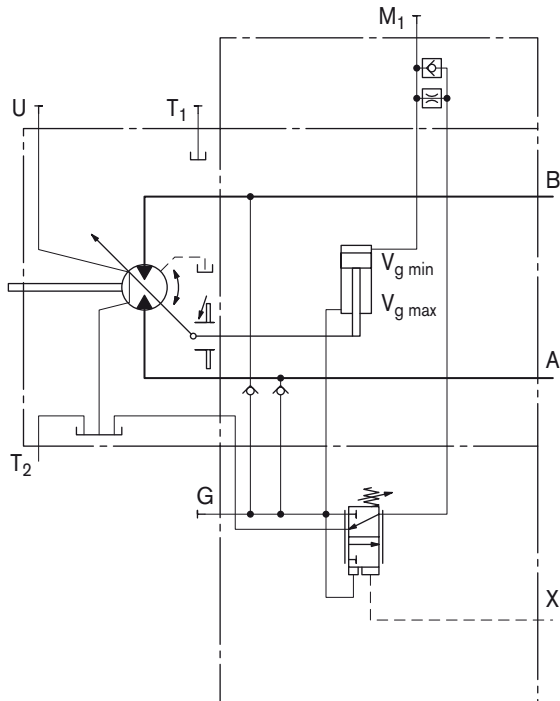

Circuit diagram HA2.T3

Sizes 60 to 215

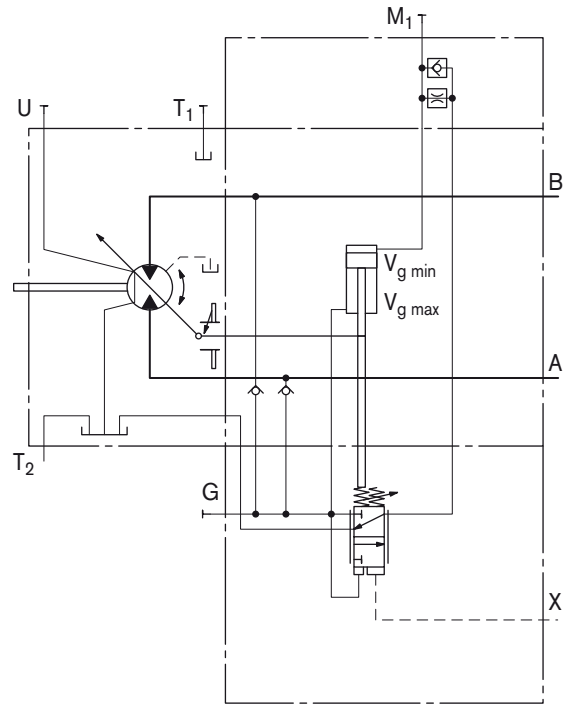

HA – Automatic control high-pressure related

HA.U1, HA.U2

Override, electric, two-point

With the HA.U1 or HA.U2 control, the start of control can be overridden by an electric signal to a switching solenoid. On override, the variable motor swivels to the maximum swivel angle without stopping at an intermediate position. The start of control can be set to between 80 and 300 bar (specify required setting in plain text when ordering).

Technical data, solenoid Ø45	U1	U2
(sizes 60 to 115)		
Voltage	12 V ($\pm 20\%$)	24 V ($\pm 20\%$)
No override	de-energized	de-energized
Position $V_{g \max}$	current energized	current energized
Nominal resistance (at 20 °C)	4.8 Ω	19.2 Ω
Nominal power	30 W	30 W
Active current, min. required	1.5 A	0.75 A
Actuated time	100 %	100 %
Type of protection see connector design, page 71		

Circuit diagram HA1U1, HA1U2

Sizes 60 to 215

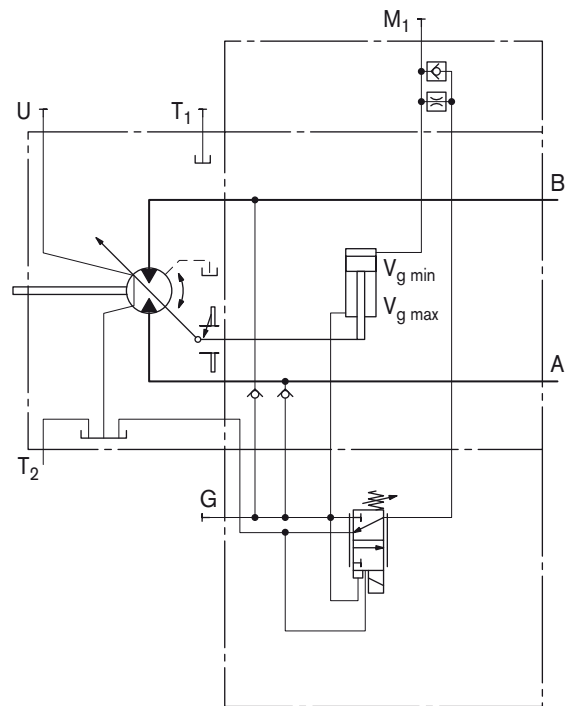

Circuit diagram HA2U1, HA2U2

Sizes 60 to 215

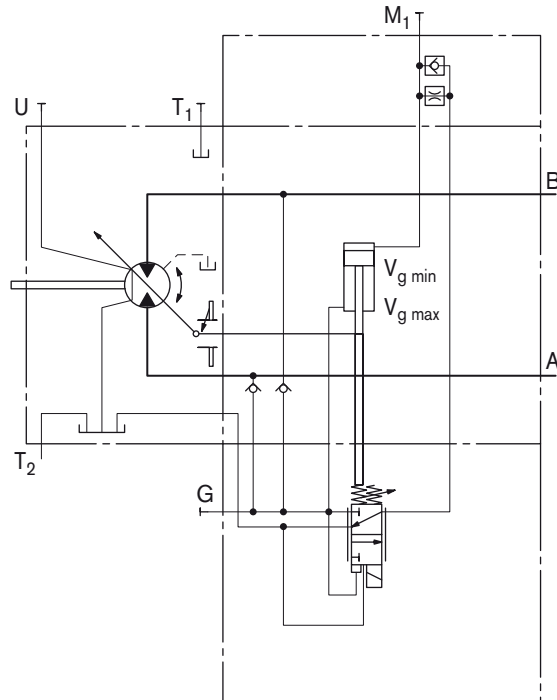

HA – Automatic control high-pressure related

HA.R1, HA.R2

Override electric, travel direction valve electric (see page 28)

With the HA.R1 or HA.R2 control, the high-pressure related closed loop control can be overridden by an electric signal to switching solenoid b. On override, the variable motor swivels to the maximum swivel angle without stopping at an intermediate position.

The travel direction valve ensures that the preselected pressure side of the hydraulic motor always controls the swivel angle, even if the high-pressure side changes (e.g. travel drive during a descent). This thereby prevents an undesired swiveling out of the variable motor to a larger displacement.

Depending on the direction of rotation (direction of travel), the travel direction valve (see page 28) can be actuated through the pressure spring or switching solenoid a.

Technical data, solenoid a with Ø37 (travel direction valve)		R1	R2
Voltage		12 V (±20 %)	24 V (±20 %)
No override		de-energized	de-energized
Direction of rotation	Operating pressure in		
counter-clockwise	B	current energized	current energized
clockwise	A	de-energized	de-energized
Nominal resistance (at 20 °C)		5.5 Ω	21.7 Ω
Nominal power		26.2 W	26.5 W
Active current, min. required		1.32 A	0.67 A
Actuated time		100 %	100 %
Type of protection see connector design, page 71			

Technical data, solenoid b with Ø45 (electric override)		R1	R2
Voltage		12 V (±20 %)	24 V (±20 %)
No override		de-energized	de-energized
Position $V_{g \max}$		current energized	current energized
Nominal resistance (at 20 °C)		4.8 Ω	19.2 Ω
Nominal power		30 W	30 W
Active current, min. required		1.5 A	0.75 A
Actuated time		100 %	100 %
Type of protection see connector design, page 71			

Circuit diagram HA1R1, HA1R2

Sizes 60 to 215

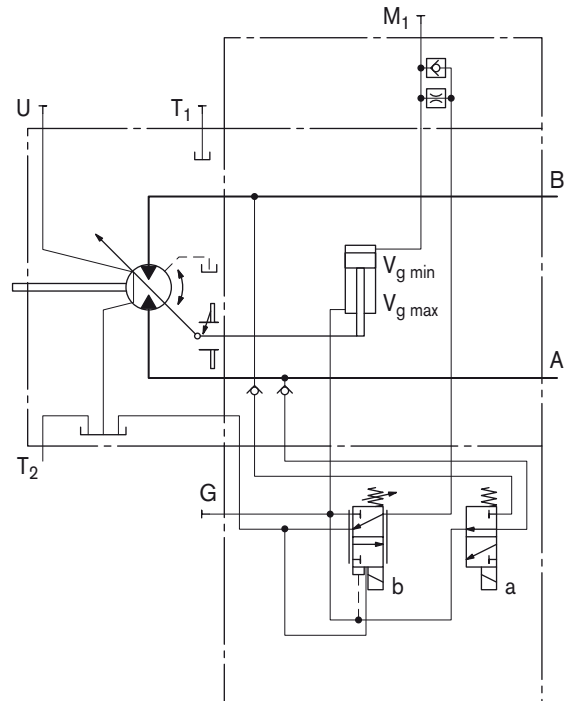

Circuit diagram HA2R1, HA2R2

Sizes 60 to 215

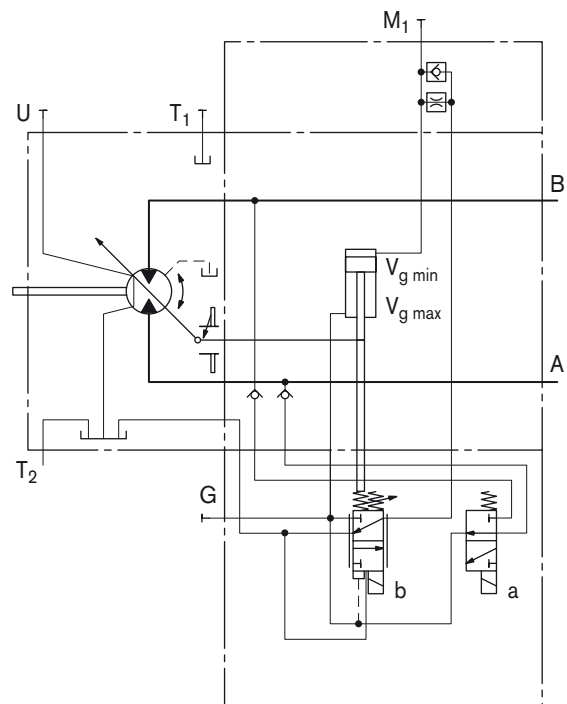

DA – Automatic control speed related

The A6VM variable motor with speed-related automatic control is best used for hydrostatic travel drives in combination with the A4VG variable pump with DA control.

The pilot pressure derived from the drive speed of the A4VG variable pump, together with the operating pressure, regulate the swivel angle of the hydraulic motor.

Increasing drive speed, i.e. increasing pilot pressure, causes the motor to swivel to a smaller displacement (lower torque, higher speed), depending on the operating pressure.

If the operating pressure increase above the pressure setting of the controller, the variable motor swivels to a larger displacement (higher torque, lower speed).

Pressure ratio p_{St}/p_{HD} _____ 5/100

A drive with DA control must be designed using the technical data of the A4VG variable pump with DA control.

Detailed information is available from our sales department and on our website www.boschrexroth.com/da-control.

Note

The start of control and the DA characteristic are influenced by the case pressure. An increase in the case pressure causes a drop in the start of control (see page 6) and thus a parallel displacement of the characteristic.

DA0 Hydraulic travel direction valve, negative control

The travel direction valve is operated according to the direction of rotation (direction of travel) using pilot pressures X_1 or X_2 .

Direction of rotation	Operating pressure in	Pilot pressure in
clockwise	A	X_1
counter-clockwise	B	X_2

Circuit diagram DA0

Sizes 60 to 215

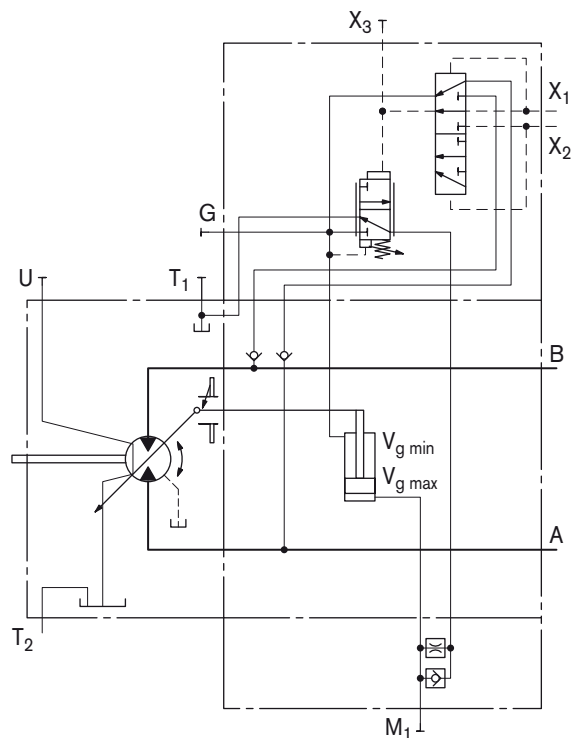

DA – Automatic control speed related

DA1, DA2 Electric travel direction valve + electric $V_{g \max}$ -circuit, negative control

Depending on the direction of rotation (direction of travel), the travel direction valve can be actuated through the pressure spring or switching solenoid a.

By connecting an electric current to switching solenoid b, the closed loop control can be overridden and the motor adjusted to maximum displacement (high torque, lower speed) (electric $V_{g \max}$ -circuit).

Technical data, solenoid a with Ø37 (travel direction valve)		DA1	DA2
Voltage		12 V ($\pm 20\%$)	24 V ($\pm 20\%$)
Direction of rotation	Operating pressure in B	de-energized	de-energized
	counter-clockwise	A	current energized
clockwise	B	current energized	current energized
Nominal resistance (at 20 °C)		5.5 Ω	21.7 Ω
Nominal power		26.2 W	26.5 W
Active current, min. required		1.32 A	0.67 A
Actuated time		100 %	100 %
Type of protection see connector design, page 71			

Technical data, solenoid b with Ø37 (electric override)		DA1	DA2
Voltage		12 V ($\pm 20\%$)	24 V ($\pm 20\%$)
No override		de-energized	de-energized
Position $V_{g \max}$		current energized	current energized
Nominal resistance (at 20 °C)		5.5 Ω	21.7 Ω
Nominal power		26.2 W	26.5 W
Active current, min. required		1.32 A	0.67 A
Actuated time		100 %	100 %
Type of protection see connector design, page 71			

Circuit diagram DA1, DA2
Sizes 60 to 215

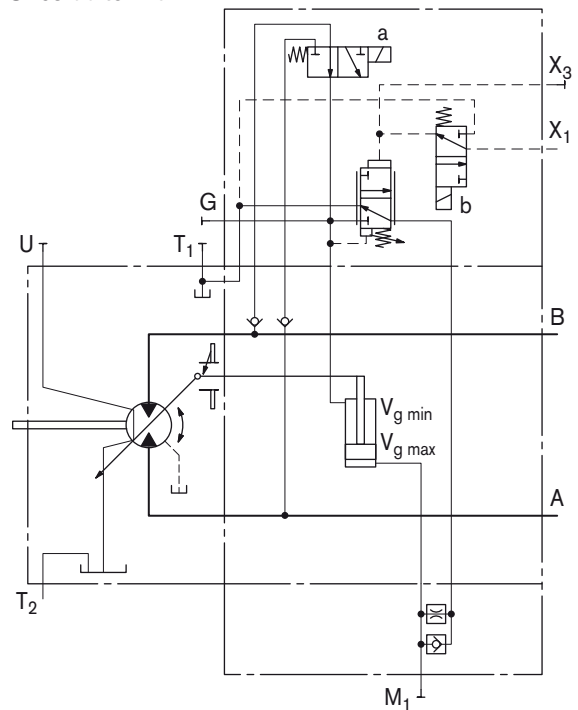

Response time damping

DA – with one-sided throttle pin – outlet to large stroking chamber

		Size					
		60	85	115	150	170	215
1	Groove size	0.45	0.45	0.55	0.55	0.55	0.65
	Material number	R909425867	R909425867	R909425868	R909425868	R909425868	R909425869

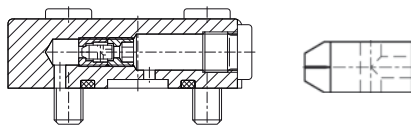

Electric travel direction valve (for DA, HA.R)

Application in travel drives in closed circuits. The travel direction valve of the motor is switched using the 4/3-directional valve on the control device of the driving pump.

When the pump in the closed circuit is switched to the neutral position or into reverse, the vehicle may experience impulsive braking depending on the vehicle's mass and current speed.

This impulsive braking is prevented through the use of the following electric control.

With this control, when the pump is switched

1. to the neutral position: the previous travel direction is retained.
2. to reverse: the motor switches to the other travel direction following a time delay (approx. 0.8 s) with respect to the pump.

Circuit diagram - electric travel direction valve

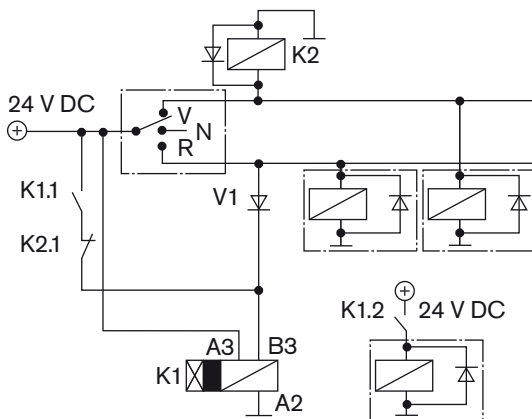

DA1, DA2 control (see page 27)

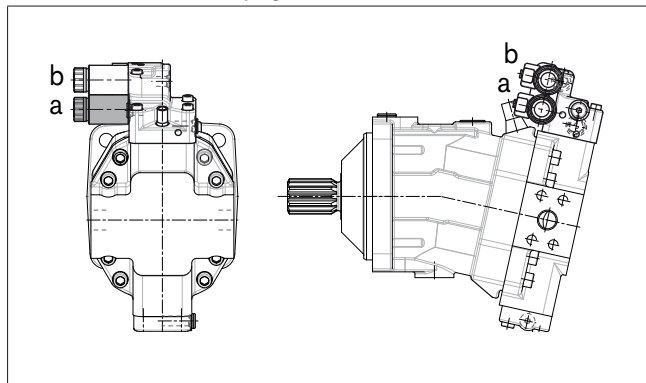

HA1R., HA2R. control (see page 25)

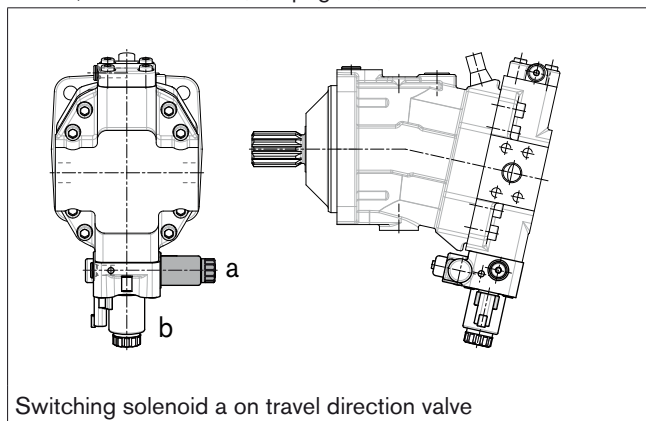

Notes

Dimensions size 60

Before finalizing your design, request a binding installation drawing. Dimensions in mm.

EP5, EP6 - Proportional control electric, negative control
 SAE flange ports A and B: at side, opposite **(port plate 2)**

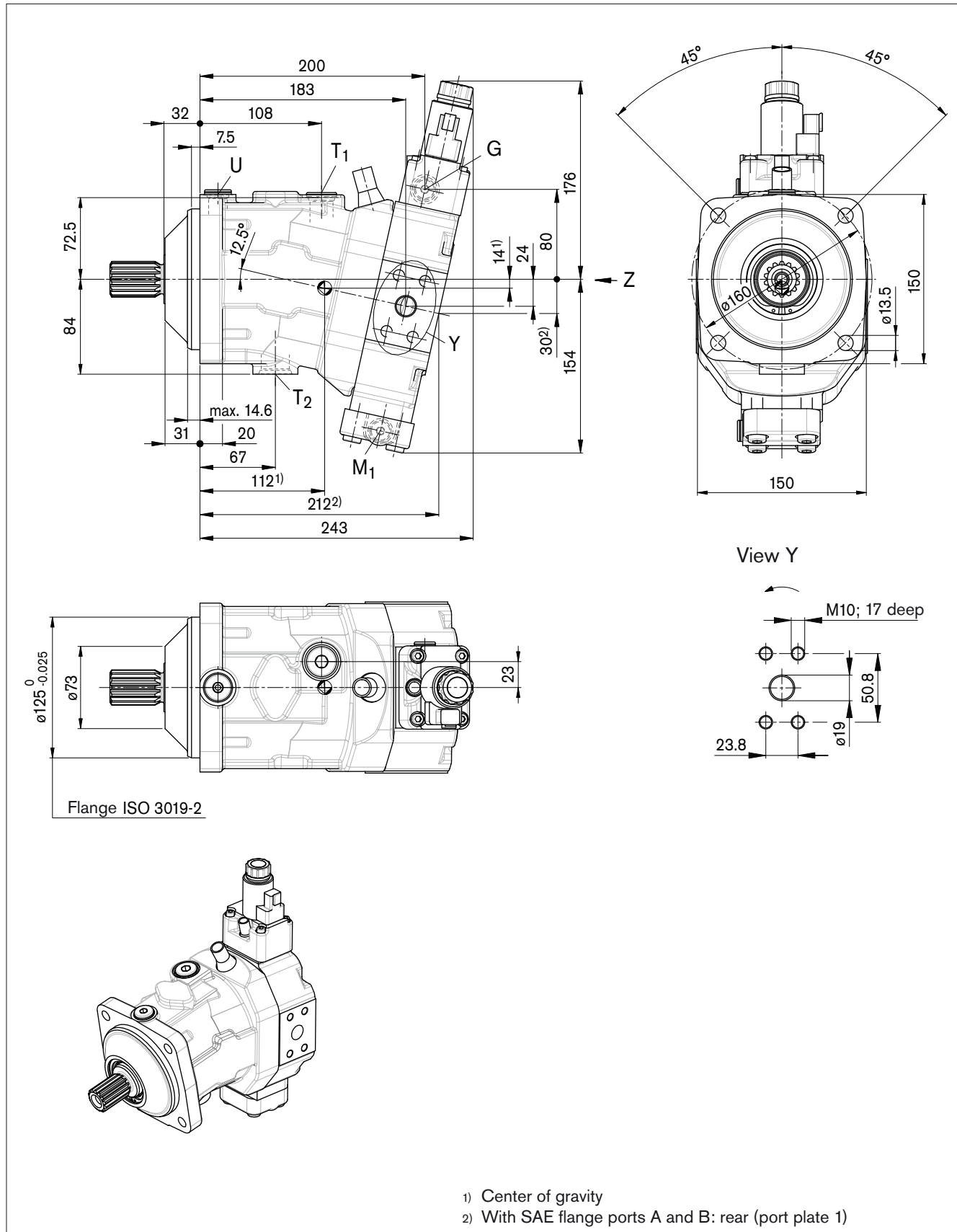

Dimensions size 60

Before finalizing your design, request a binding installation drawing. Dimensions in mm.

View Z

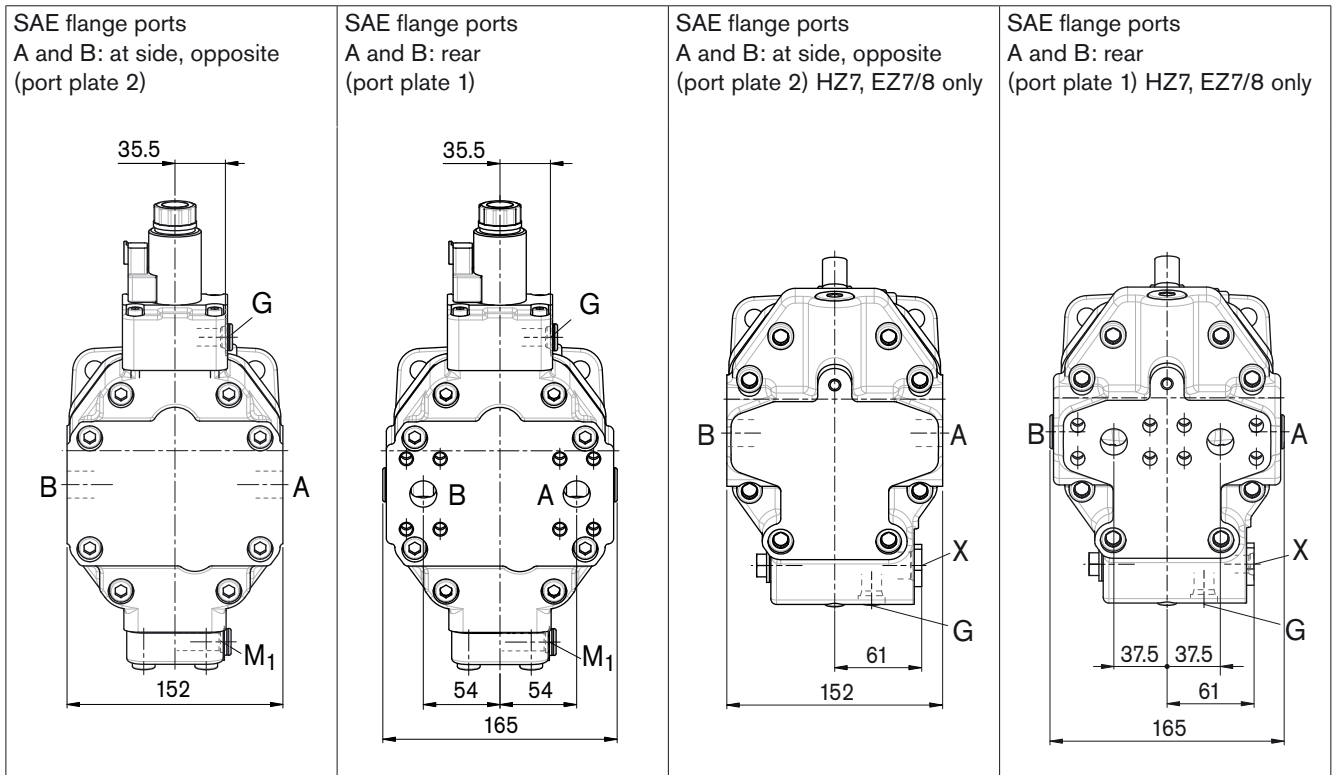

Drive shaft

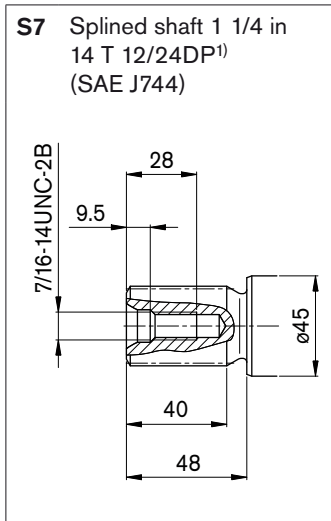

1) ANSI B92.1a-1976, 30° pressure angle, flat root, side fit, tolerance class 5

Dimensions size 60

Before finalizing your design, request a binding installation drawing. Dimensions in mm.

Ports

Designation	Port for	Standard	Size ¹⁾	Maximum pressure [bar] ²⁾	State
A, B	Service line Fixing thread A/B	SAE J518 ³⁾ DIN 13	3/4 in M10 x 1.5; 17 deep	500	O
T ₁	Tank	ISO 6149	M22 x 1.5; 15.5 deep	3	X ⁴⁾
T ₂	Tank	ISO 6149	M27 x 2; 19 deep	3	O ⁴⁾
G	Synchronous control	ISO 6149	M14 x 1.5; 11.5 deep	500	X
U	Bearing flushing	ISO 6149	M18 x 1.5; 14.5 deep	3	X
X	Pilot signal (HP, HZ, HA1T/HA2T)	ISO 6149	M14 x 1.5; 11.5 deep	100	O
X	Pilot signal (HA1 and HA2)	ISO 6149	M14 x 1.5; 11.5 deep	3	X
X ₁ , X ₂	Pilot signal (DA0)	ISO 8434-1	SDSC-L8xM12-F	40	O
X ₁	Pilot signal (DA1, DA2)	ISO 6149	M14 x 1.5; 11.5 deep	40	O
X ₃	Pilot signal (DA1, DA2)	ISO 6149	M14 x 1.5; 11.5 deep	40	X
M ₁	Measuring stroking chamber	ISO 6149	M14 x 1.5; 11.5 deep	500	X

1) Observe the general instructions on page 80 for the maximum tightening torques.

2) Short-term pressure spikes may occur depending on the application. Keep this in mind when selecting measuring devices and fittings.

3) Only dimensions according to SAE J518

4) Depending on installation position, T₁ or T₂ must be connected (see also page 76).

O = Must be connected (plugged on delivery)

X = Plugged (in normal operation)

Note

The ports and fixing threads are designed for the specified maximum pressure. The machine or system manufacturer must ensure that the connecting elements and lines correspond to the specified operating conditions (pressure, flow, hydraulic fluid, temperature) with the necessary safety factors.

Dimensions size 60

Before finalizing your design, request a binding installation drawing. Dimensions in mm.

EP1, EP2

Proportional control electric, positive control

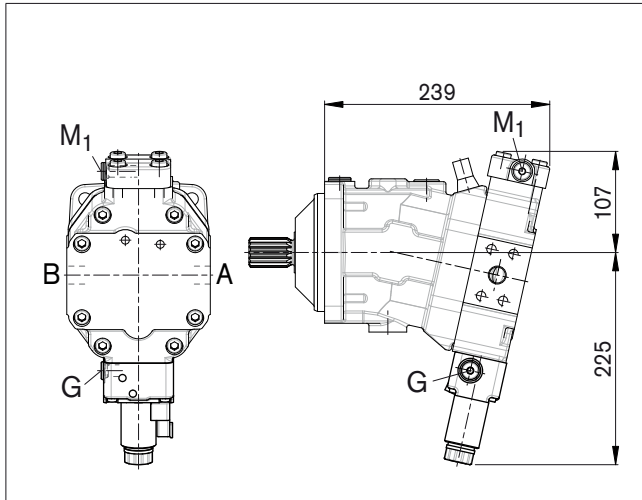

EP5D1, EP6D1

Proportional control electric, negative control, with pressure control, fixed setting

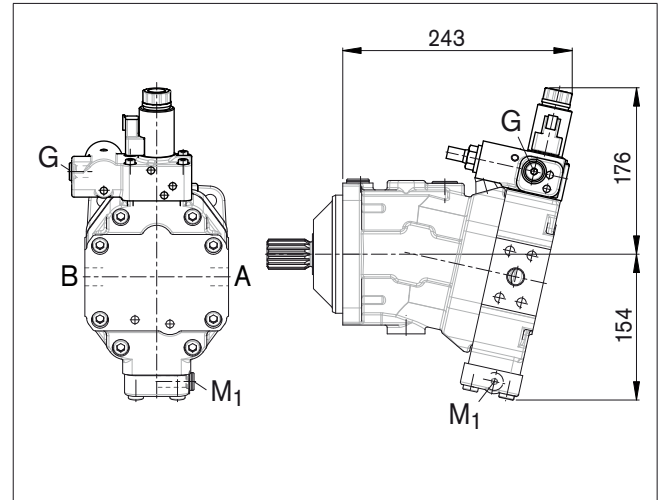

HP1, HP2

Proportional control hydraulic, positive control

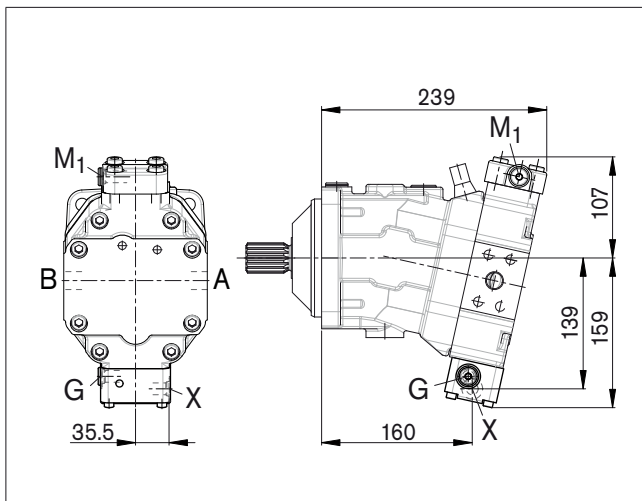

HP5, HP6

Proportional control hydraulic, negative control

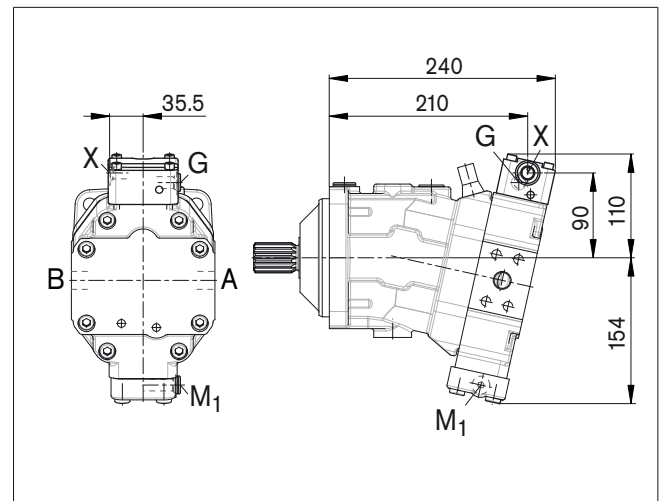

HP5D1, HP6D1

Proportional control hydraulic, negative control, with pressure control, fixed setting

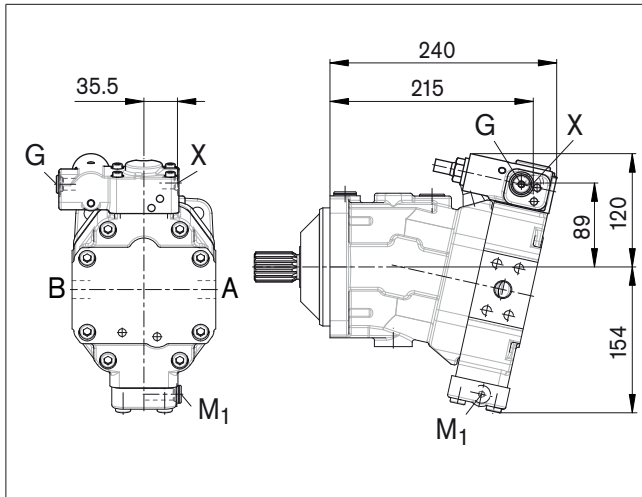

Dimensions size 60

Before finalizing your design, request a binding installation drawing. Dimensions in mm.

HZ7

Two-point control hydraulic, negative control

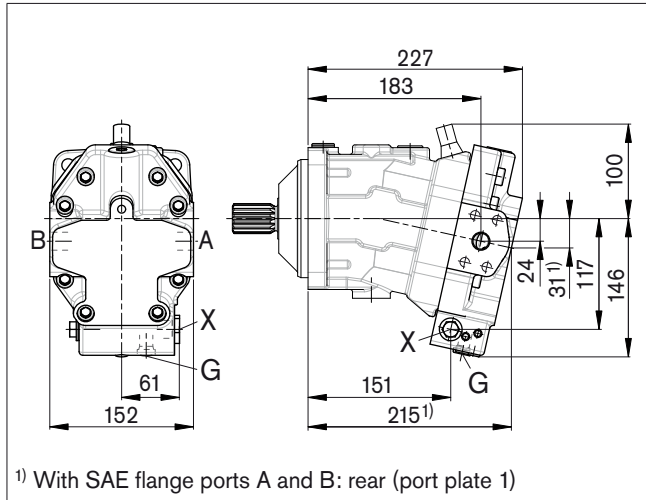

1) With SAE flange ports A and B: rear (port plate 1)

EZ7, EZ8

Two-point control electric, negative control

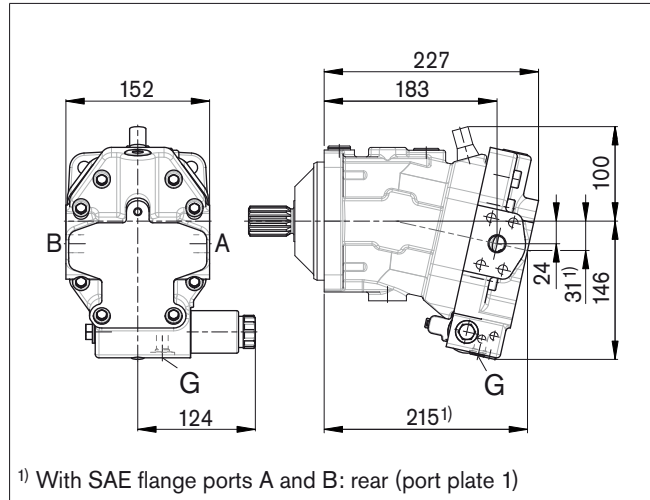

1) With SAE flange ports A and B: rear (port plate 1)

HA1, HA2 / HA1T3, HA2T3

Automatic control high-pressure related, positive control, with override, hydraulic remote control, proportional

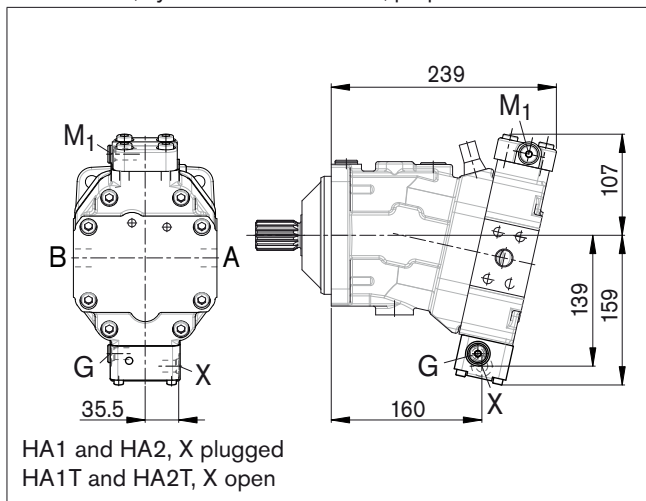

HA1 and HA2, X plugged
HA1T and HA2T, X open

HA1U1, HA2U2

Automatic control high-pressure related, positive control, with override, electric, two-point

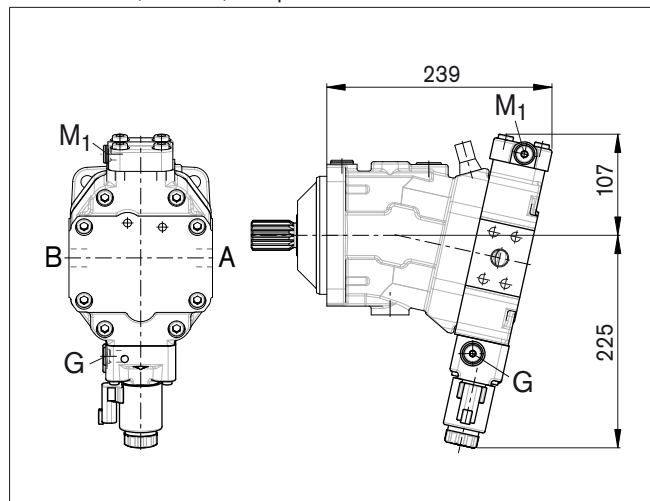

HA1R1, HA2R2

Automatic control high-pressure related, positive control, with override, electric and travel direction valve, electric

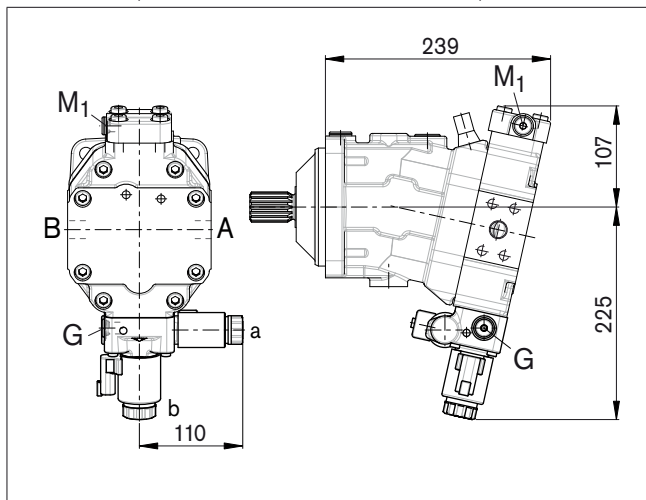

Dimensions size 60

Before finalizing your design, request a binding installation drawing. Dimensions in mm.

DA0

Automatic control speed related, negative control, hydraulic travel direction valve

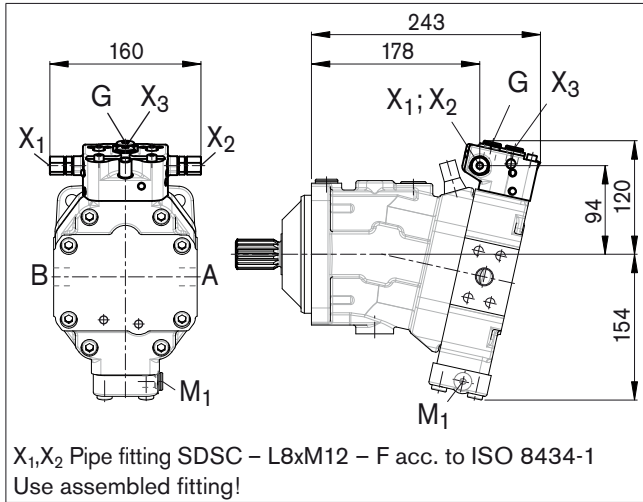

DA1, DA2

Automatic control speed related, negative control, electric travel direction valve and electric V_{Gmax} circuit

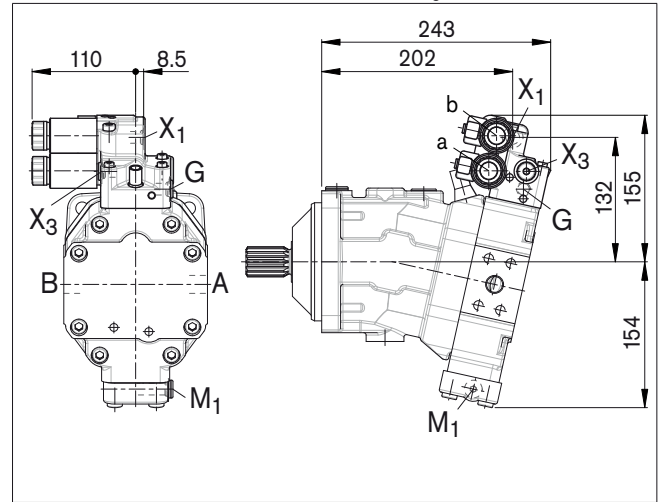

Dimensions size 85

Before finalizing your design, request a binding installation drawing. Dimensions in mm.

EP5, EP6 - Proportional control electric, negative control
SAE flange ports A and B: at side, opposite (port plate 2)

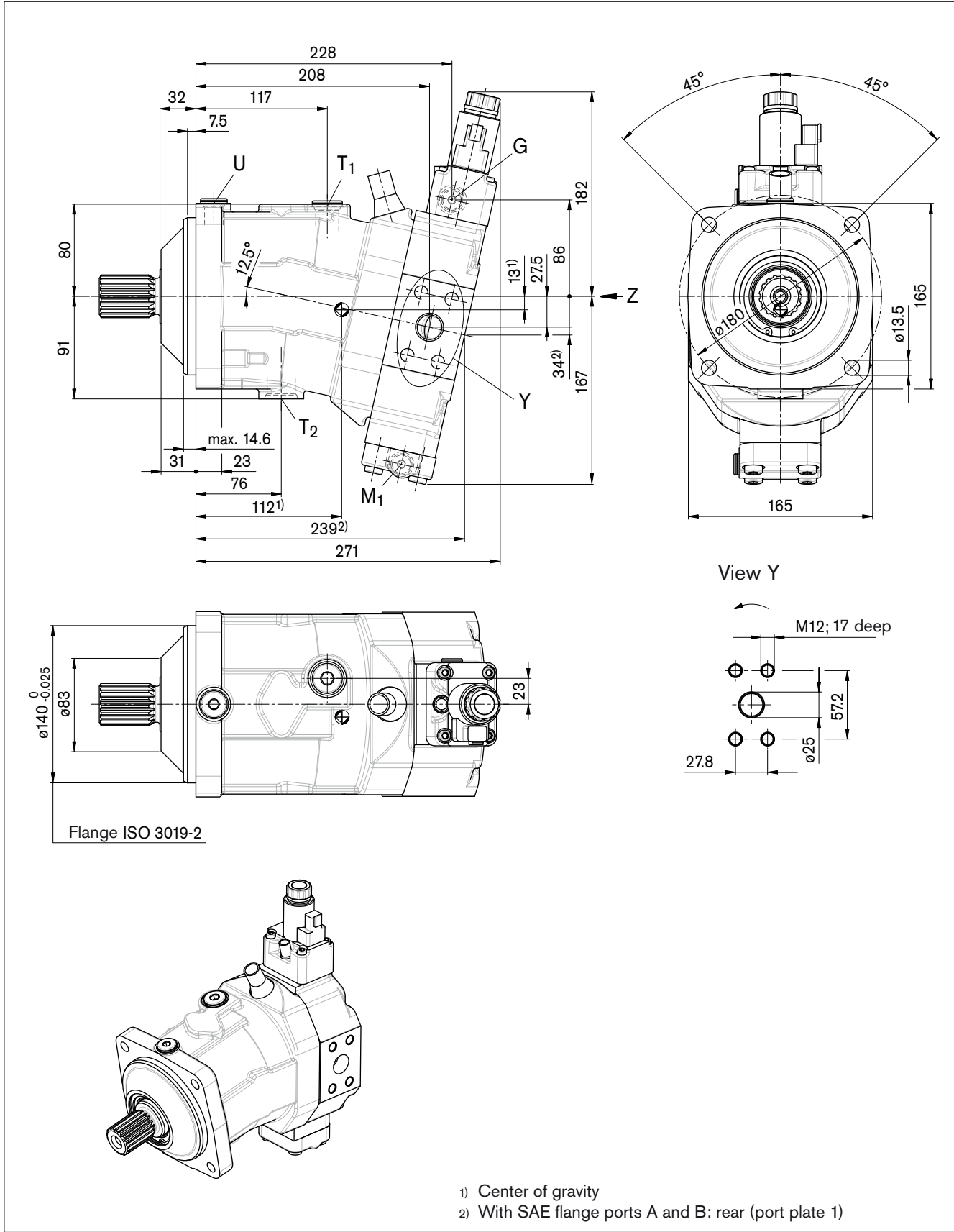

Dimensions size 85

Before finalizing your design, request a binding installation drawing. Dimensions in mm.

View Z

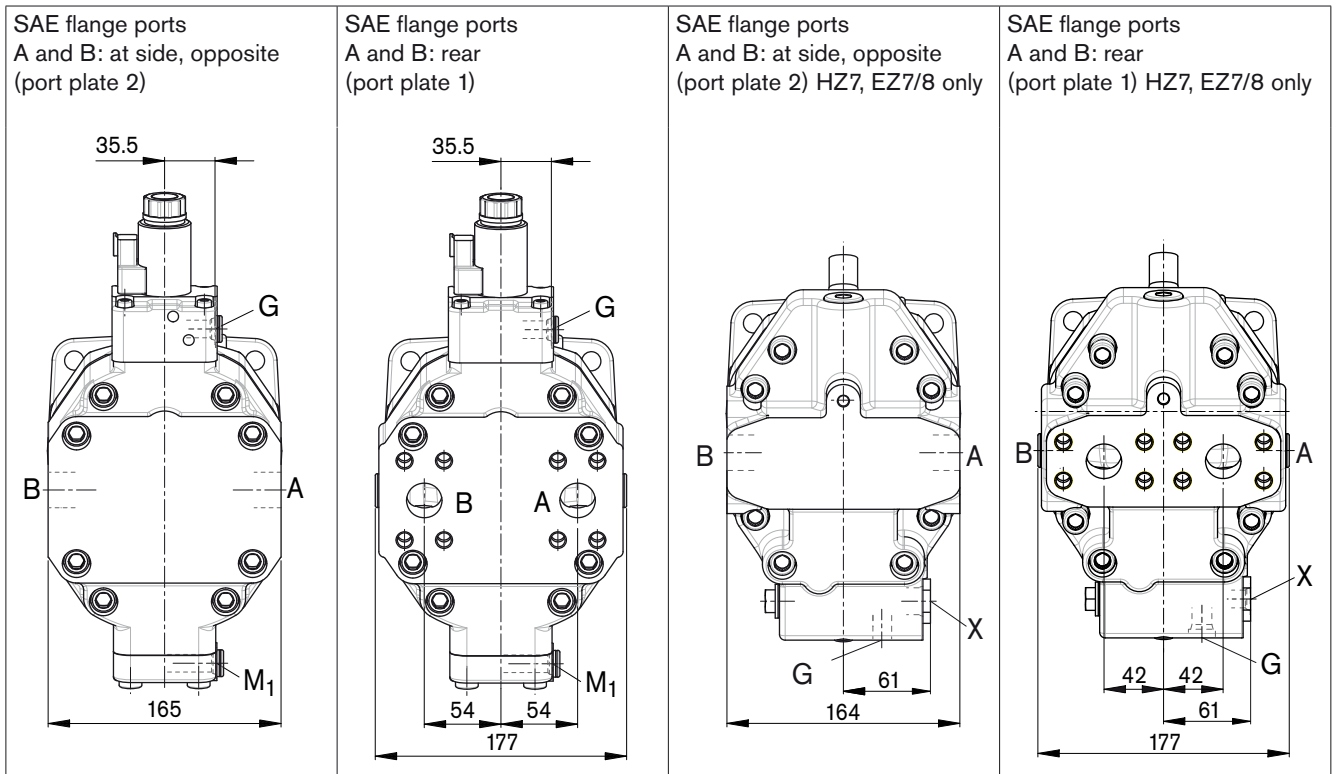

Drive shaft

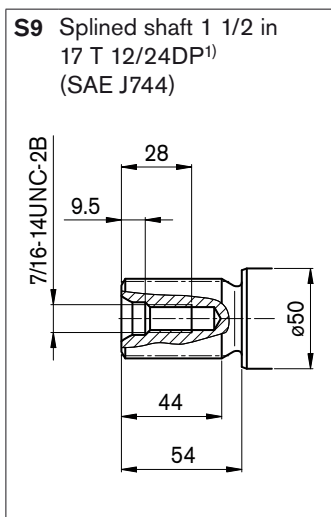

1) ANSI B92.1a-1976, 30° pressure angle, flat root, side fit, tolerance class 5

Dimensions size 85

Before finalizing your design, request a binding installation drawing. Dimensions in mm.

Ports

Designation	Port for	Standard	Size ¹⁾	Maximum pressure [bar] ²⁾	State
A, B	Service line, Fixing thread A/B	SAE J518 ³⁾ DIN 13	1 in M12 x 1.75; 17 deep	500	O
T ₁	Tank	ISO 6149	M22 x 1.5; 15.5 deep	3	X ⁴⁾
T ₂	Tank	ISO 6149	M27 x 2; 19 deep	3	O ⁴⁾
G	Synchronous control	ISO 6149	M14 x 1.5; 11.5 deep	500	X
U	Bearing flushing	ISO 6149	M18 x 1.5; 14.5 deep	3	X
X	Pilot signal (HP, HZ, HA1T/HA2T)	ISO 6149	M14 x 1.5; 11.5 deep	100	O
X	Pilot signal (HA1 and HA2)	ISO 6149	M14 x 1.5; 11.5 deep	3	X
X ₁ , X ₂	Pilot signal (DA0)	ISO 8434-1	SDSC-L8xM12-F	40	O
X ₁	Pilot signal (DA1, DA2)	ISO 6149	M14 x 1.5; 11.5 deep	40	O
X ₃	Pilot signal (DA1, DA2)	ISO 6149	M14 x 1.5; 11.5 deep	40	X
M ₁	Measuring, stroking chamber	ISO 6149	M14 x 1.5; 11.5 deep	500	X

1) Observe the general instructions on page 80 for the maximum tightening torques.

2) Short-term pressure spikes may occur depending on the application. Keep this in mind when selecting measuring devices and fittings.

3) Only dimensions according to SAE J518

4) Depending on installation position, T₁ or T₂ must be connected (see also page 76).

O = Must be connected (plugged on delivery)

X = Plugged (in normal operation)

Note

The ports and fixing threads are designed for the specified maximum pressure. The machine or system manufacturer must ensure that the connecting elements and lines correspond to the specified operating conditions (pressure, flow, hydraulic fluid, temperature) with the necessary safety factors.

Dimensions size 85

Before finalizing your design, request a binding installation drawing. Dimensions in mm.

EP1, EP2

Proportional control electric, positive control

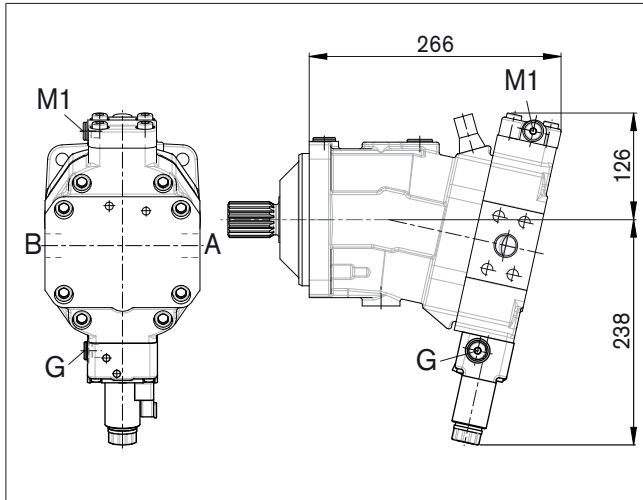

EP5D1, EP6D1

Proportional control electric, negative control, with pressure setting, fixed setting

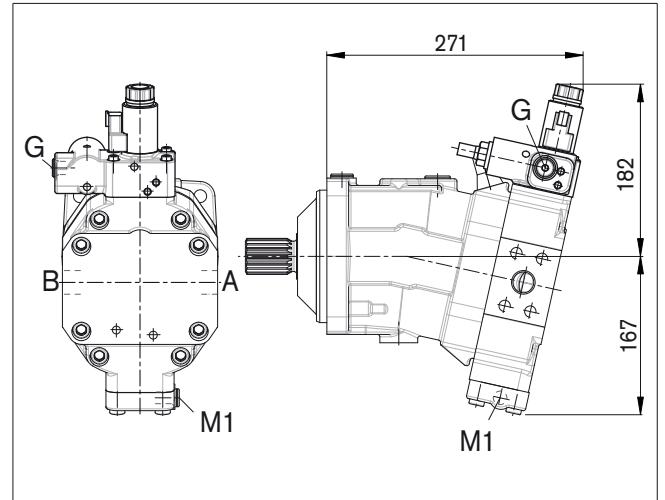

HP1, HP2

Proportional control hydraulic, positive control

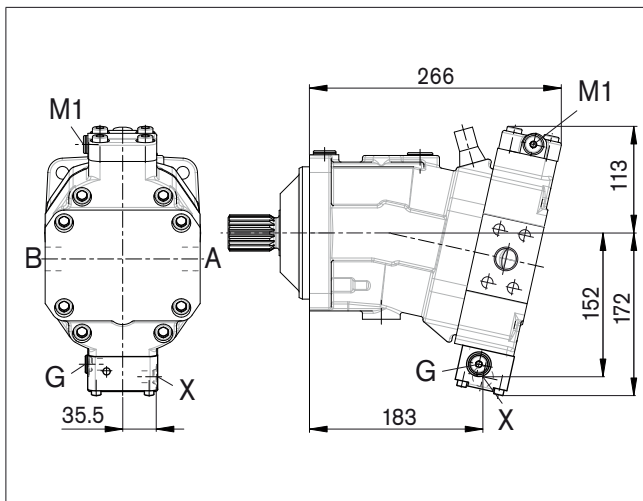

HP5, HP6

Proportional control hydraulic, negative control

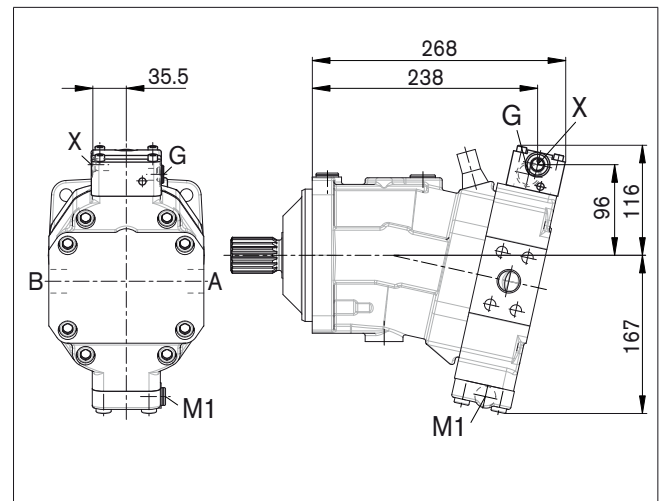

HP5D1, HP6D1

Proportional control hydraulic, negative control, with pressure control, fixed setting

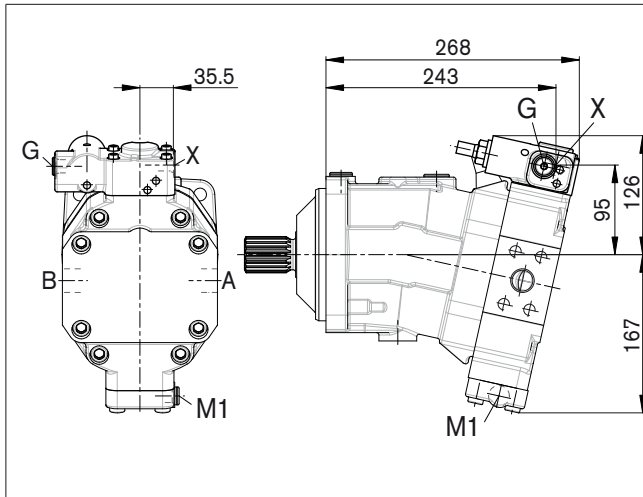

Dimensions size 85

Before finalizing your design, request a binding installation drawing. Dimensions in mm.

HZ7

Two-point control hydraulic, negative control

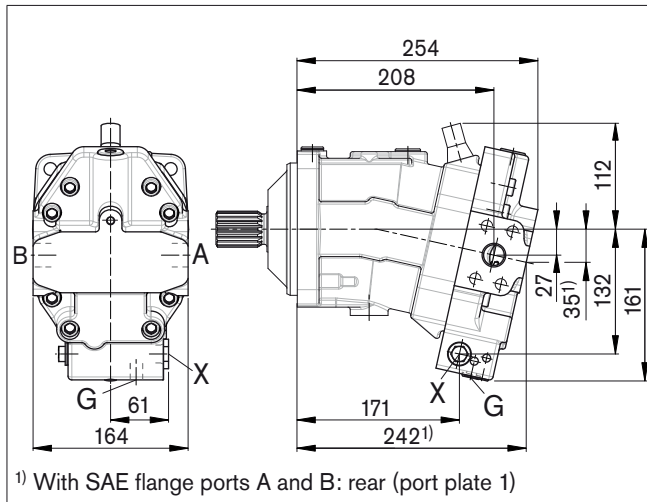

EZ7, EZ8

Two-point control electric, negative control

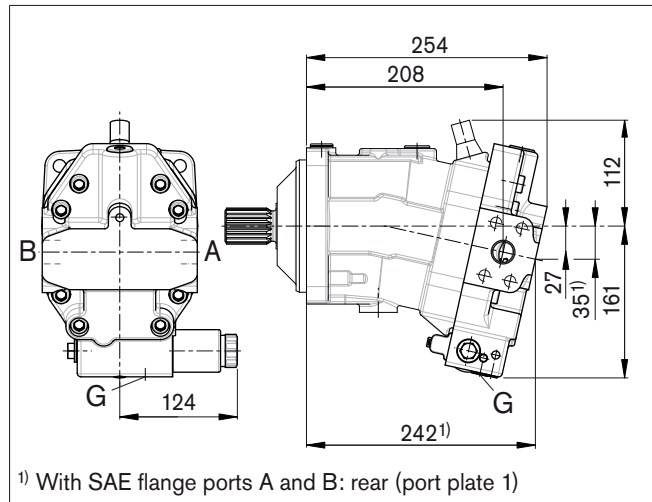

HA1, HA2 / HA1T3, HA2T3

Automatic control high-pressure related, positive control, with override, hydraulic remote control, proportional

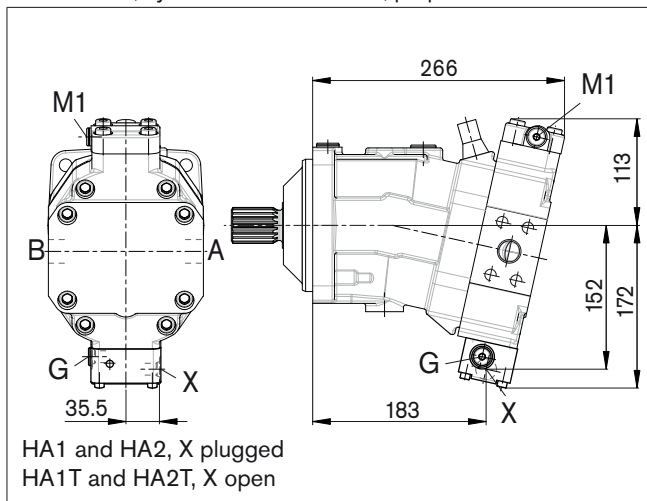

HA1U1, HA2U2

Automatic control high-pressure related, positive control, with override, electric, two-point

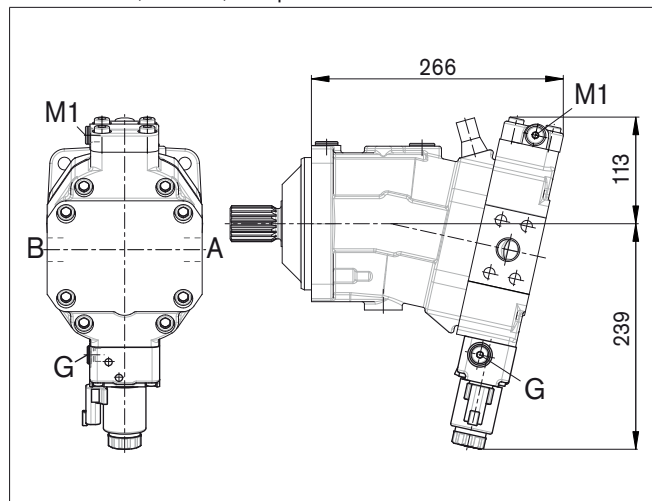

HA1R1, HA2R2

Automatic control high-pressure related, positive control, with override, electric and travel direction valve, electric

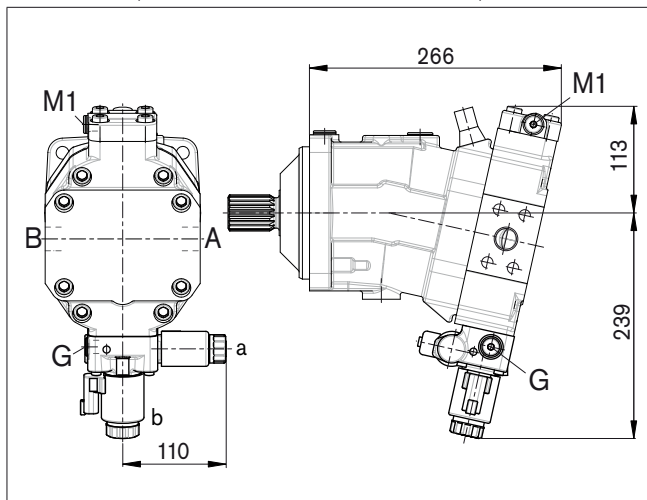

Dimensions size 85

Before finalizing your design, request a binding installation drawing. Dimensions in mm.

DA0

Automatic control speed related, negative control, hydraulic travel direction valve

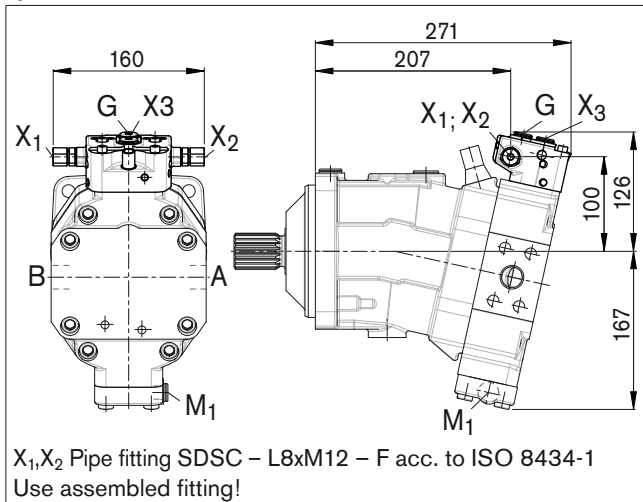

DA1, DA2

Automatic control speed related, negative control, electric travel direction valve and electric V_{Gmax}- circuit

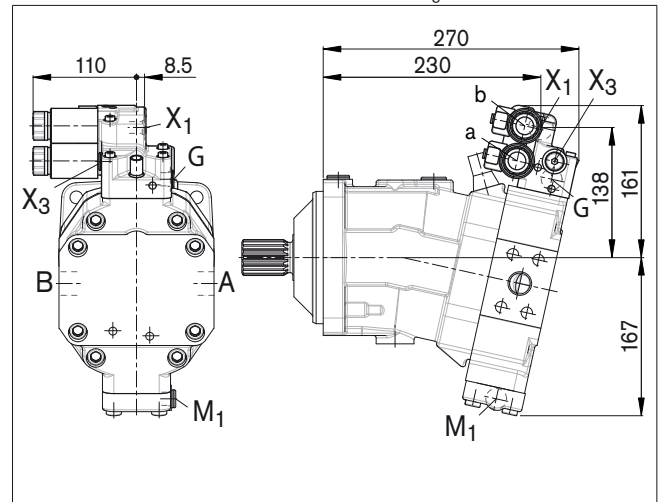

Dimensions size 115

Before finalizing your design, request a binding installation drawing. Dimensions in mm.

EP5, EP6 - Proportional control electric, negative control
 SAE flange ports A and B: at side, opposite (port plate 2)

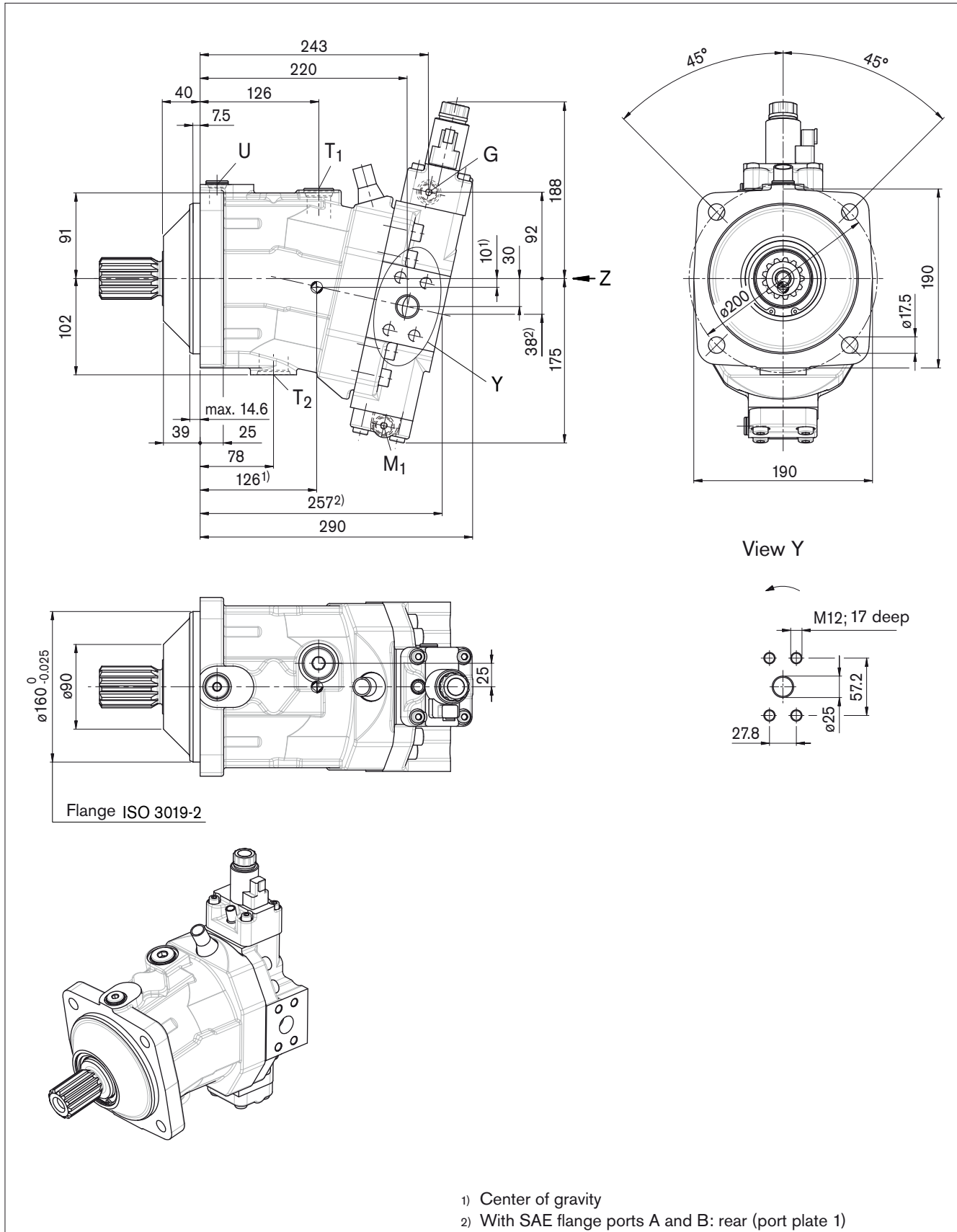

Dimensions size 115

Before finalizing your design, request a binding installation drawing. Dimensions in mm.

View Z

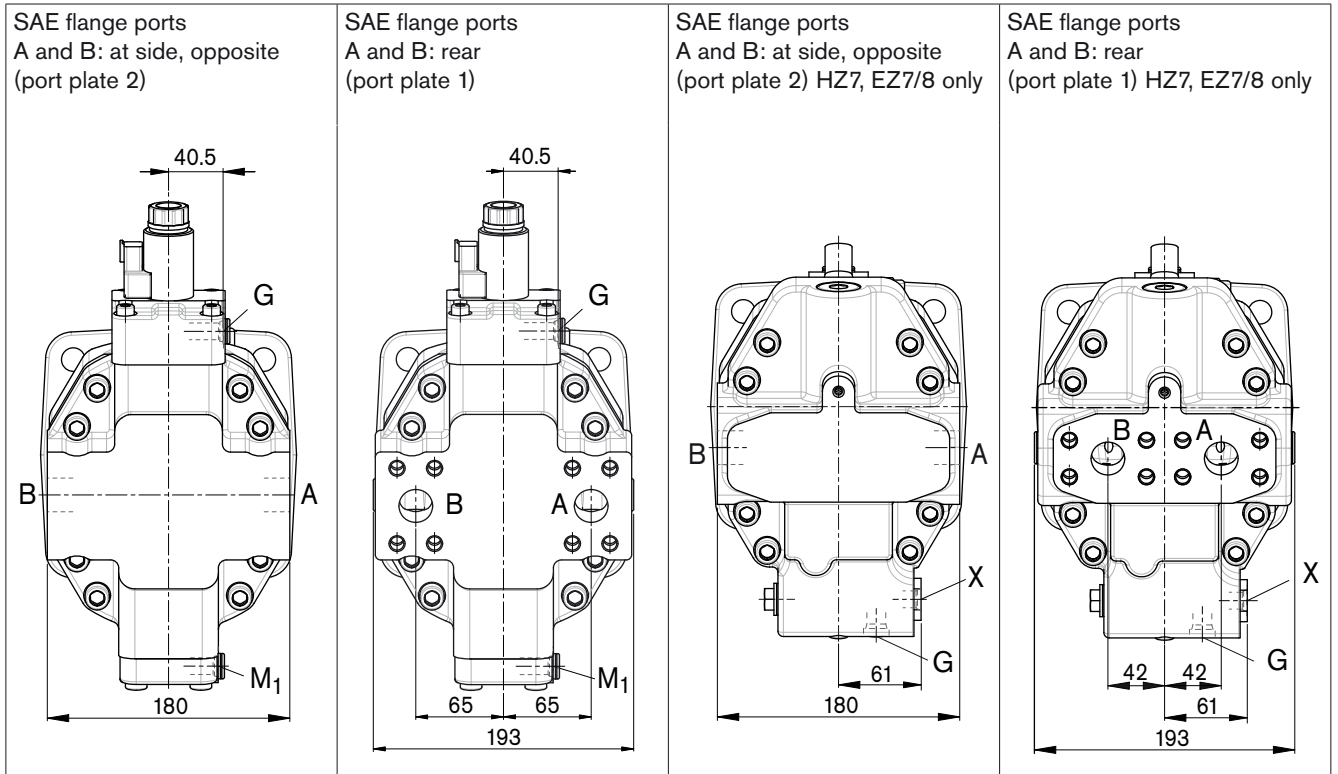

Drive shaft

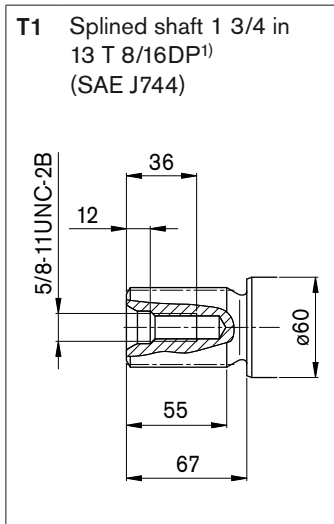

1) ANSI B92.1a-1976, 30° pressure angle, flat root, side fit, tolerance class 5

Dimensions size 115

Before finalizing your design, request a binding installation drawing. Dimensions in mm.

Ports

Designation	Port for	Standard	Size ¹⁾	Maximum pressure [bar] ²⁾	State
A, B	Service line, Fixing thread A/B	SAE J518 ³⁾ DIN 13	1 in M12 x 1.75; 17 deep	500	O
T ₁	Tank	ISO 6149	M27 x 2; 19 deep	3	X ⁴⁾
T ₂	Tank	ISO 6149	M33 x 2; 19 deep	3	O ⁴⁾
G	Synchronous control	ISO 6149	M14 x 1.5; 11.5 deep	500	X
U	Bearing flushing	ISO 6149	M18 x 1.5; 14.5 deep	3	X
X	Pilot signal (HP, HZ, HA1T/HA2T)	ISO 6149	M14 x 1.5; 11.5 deep	100	O
X	Pilot signal (HA1 and HA2)	ISO 6149	M14 x 1.5; 11.5 deep	3	X
X ₁ , X ₂	Pilot signal (DA0)	ISO 8434-1	SDSC-L8xM12-F	40	O
X ₁	Pilot signal (DA1, DA2)	ISO 6149	M14 x 1.5; 11.5 deep	40	O
X ₃	Pilot signal (DA1, DA2)	ISO 6149	M14 x 1.5; 11.5 deep	40	X
M ₁	Measuring, stroking chamber	ISO 6149	M14 x 1.5; 11.5 deep	500	X

1) Observe the general instructions on page 80 for the maximum tightening torques.

2) Short-term pressure spikes may occur depending on the application. Keep this in mind when selecting measuring devices and fittings.

3) Only dimensions according to SAE J518

4) Depending on installation position, T₁ or T₂ must be connected (see also page 76).

O = Must be connected (plugged on delivery)

X = Plugged (in normal operation)

Note

The ports and fixing threads are designed for the specified maximum pressure. The machine or system manufacturer must ensure that the connecting elements and lines correspond to the specified operating conditions (pressure, flow, hydraulic fluid, temperature) with the necessary safety factors.

Dimensions size 115

Before finalizing your design, request a binding installation drawing. Dimensions in mm.

EP1, EP2

Proportional control electric, positive control

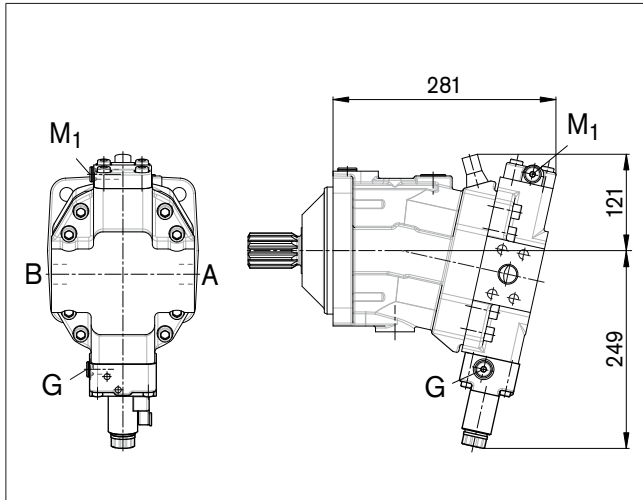

EP5D1, EP6D1

Proportional control electric, negative control, with pressure control, fixed setting

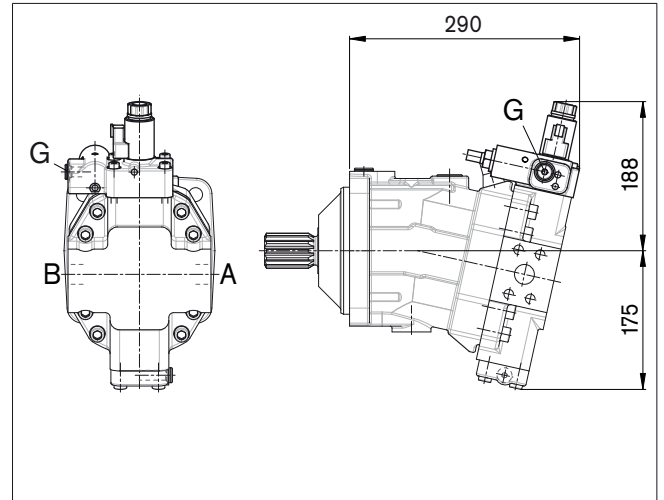

HP1, HP2

Proportional control hydraulic, positive control

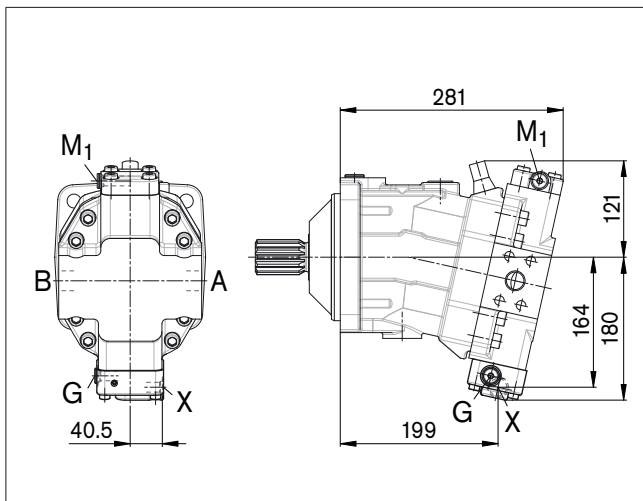

HP5, HP6

Proportional control hydraulic, negative control

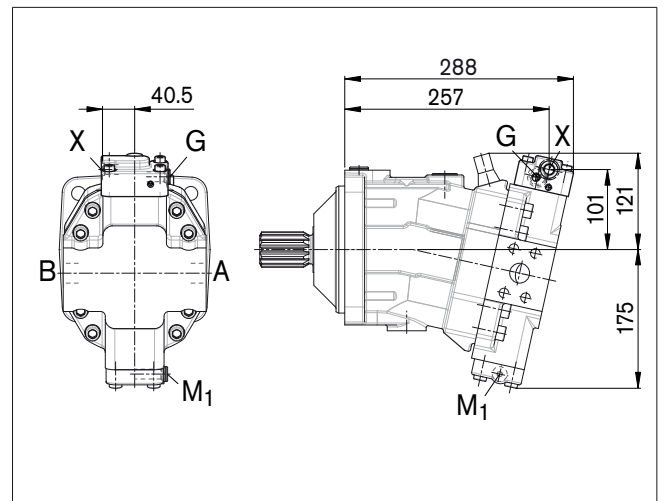

HP5D1, HP6D1

Proportional control hydraulic, negative control, with pressure control, fixed setting

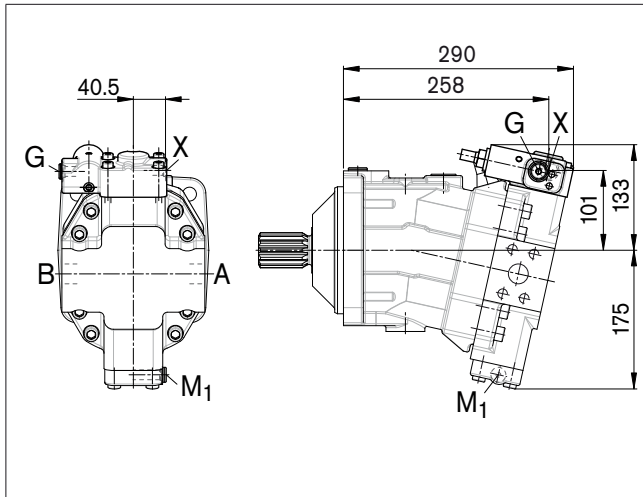

Dimensions size 115

Before finalizing your design, request a binding installation drawing. Dimensions in mm.

HZ7

Two-point control hydraulic, negative control

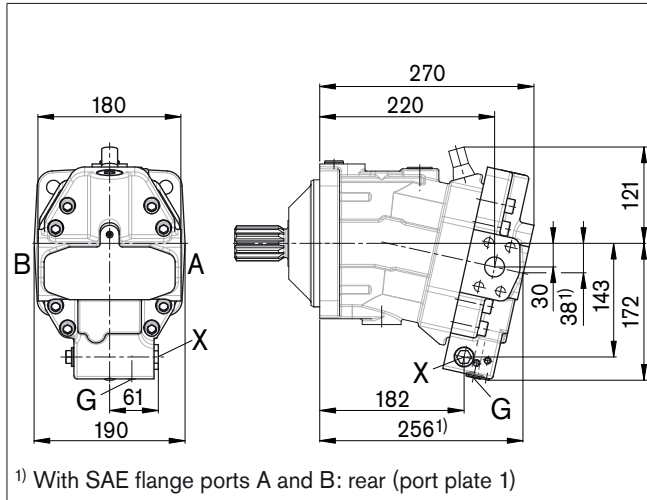

EZ7, EZ8

Two-point control electric, negative control

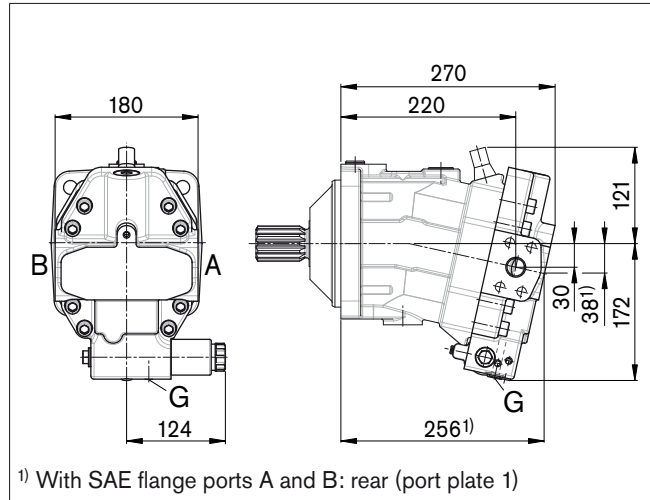

HA1, HA2 / HA1T3, HA2T3

Automatic control high-pressure related, positive control, with override, hydraulic remote control, proportional

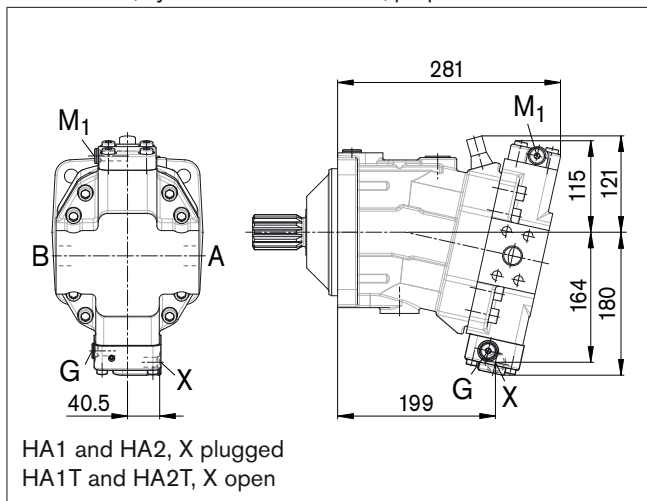

HA1U1, HA2U2

Automatic control high-pressure related, positive control, with override, electric, two-point

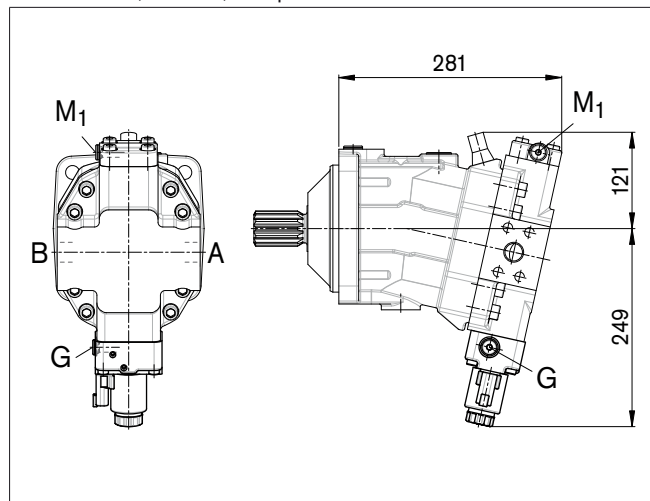

HA1R1, HA2R2

Automatic control high-pressure related, positive control, with override, electric and travel direction valve, electric

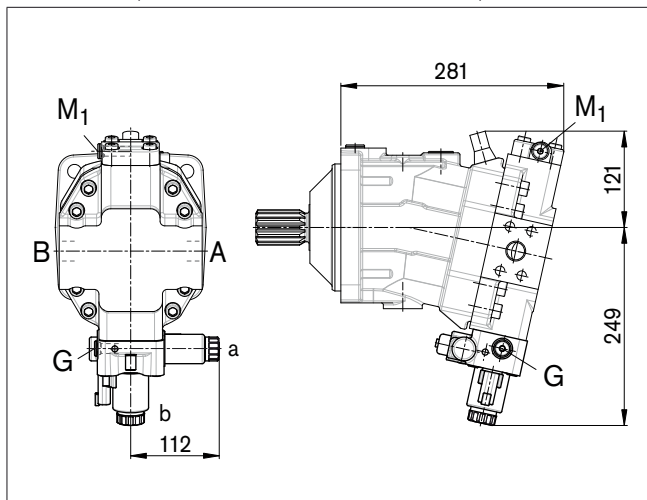

Dimensions size 115

Before finalizing your design, request a binding installation drawing. Dimensions in mm.

DA0

Automatic control speed related, negative control, hydraulic travel direction valve

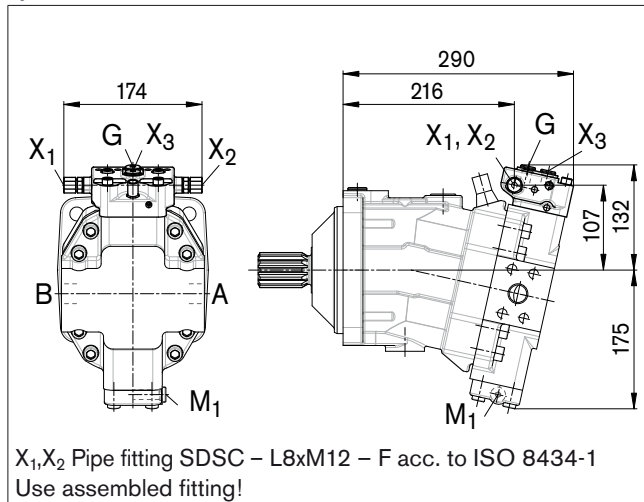

DA1, DA2

Automatic control speed related, negative control, electric travel direction valve and electric V_{Gmax} circuit

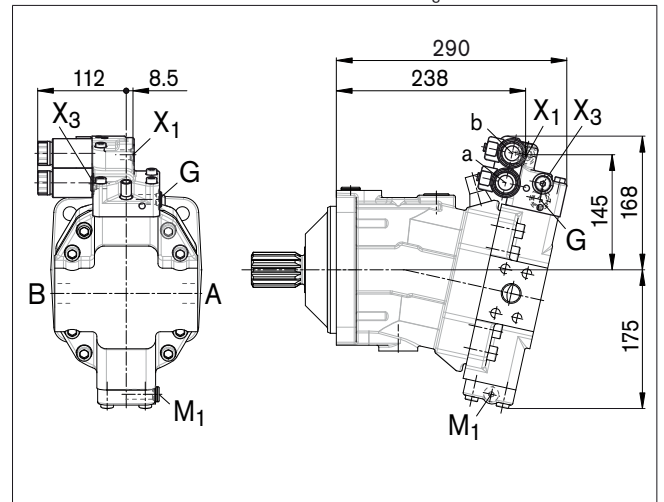

Dimensions size 150

Before finalizing your design, request a binding installation drawing. Dimensions in mm.

EP5, EP6 - Proportional control electric, negative control
SAE flange ports A and B: at side, opposite (port plate 2)

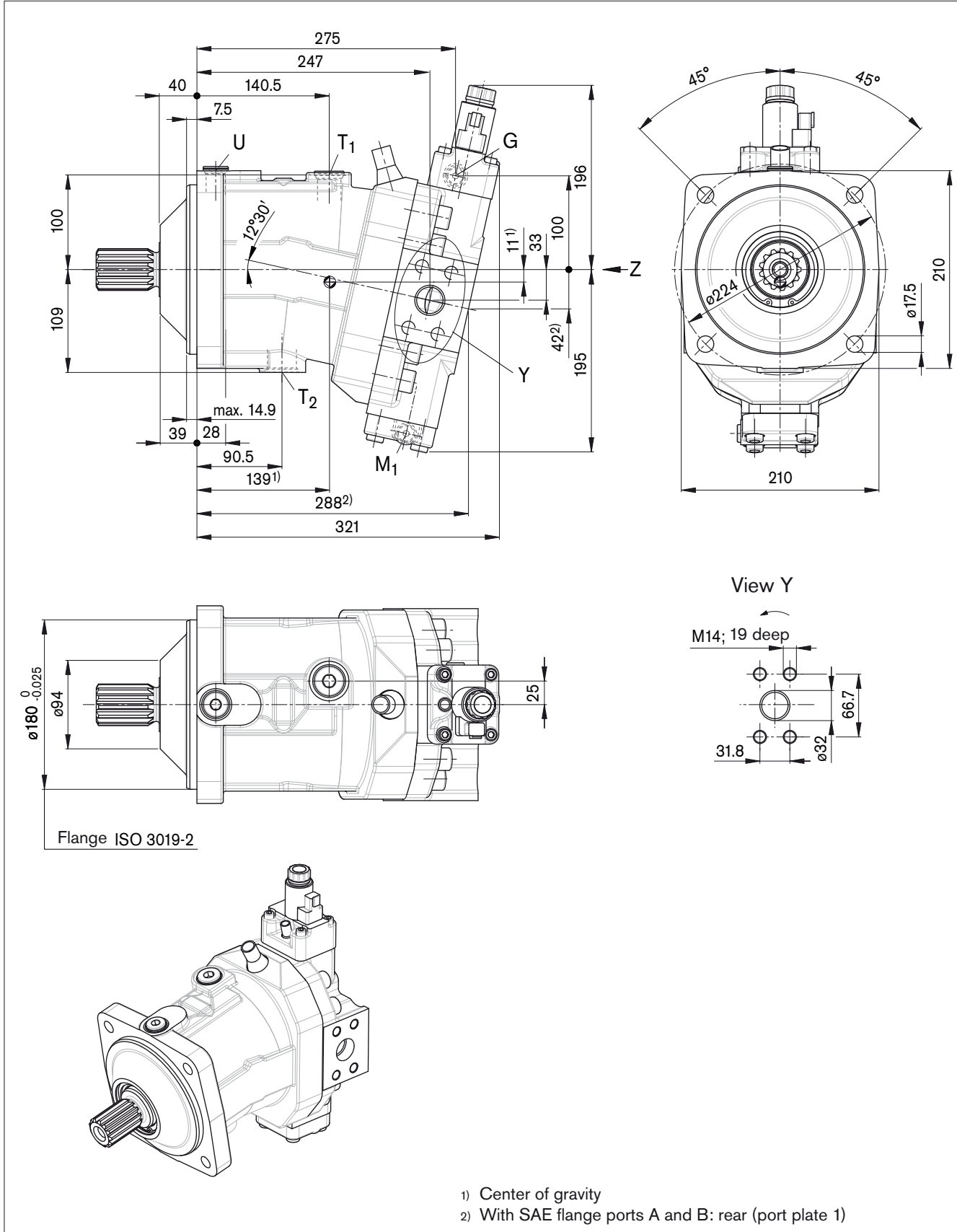

Dimensions size 150

Before finalizing your design, request a binding installation drawing. Dimensions in mm.

View Z

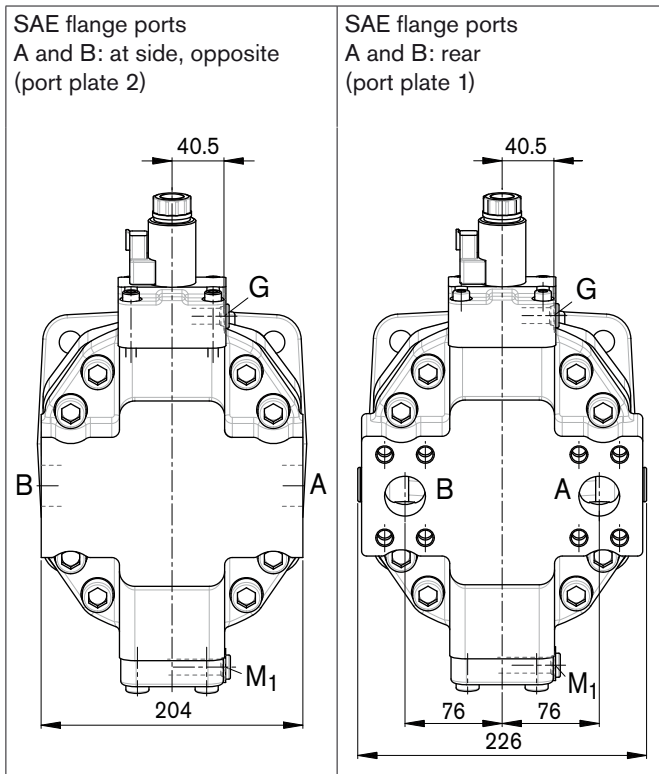

Drive shaft

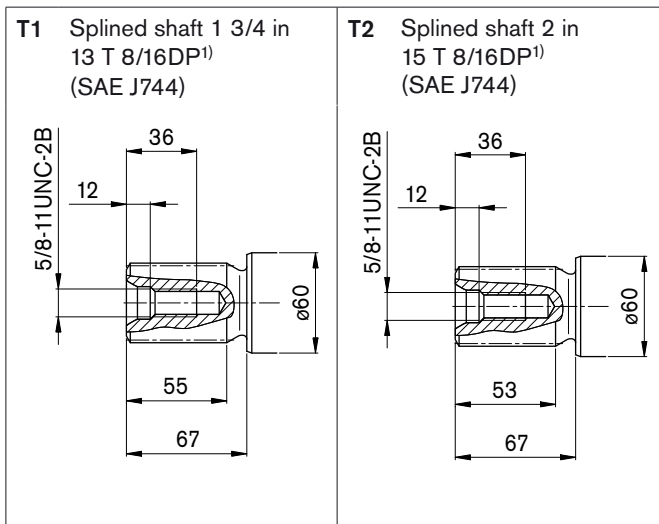

1) ANSI B92.1a-1976, 30° pressure angle, flat root, side fit, tolerance class 5

Dimensions size 150

Before finalizing your design, request a binding installation drawing. Dimensions in mm.

Ports

Designation	Port for	Standard	Size ¹⁾	Maximum pressure [bar] ²⁾	State
A, B	Service line, Fixing thread A/B	SAE J518 ³⁾ DIN 13	1 1/4 in M14 x 2; 19 deep	500	O
T ₁	Tank	ISO 6149	M27 x 2; 19 deep	3	X ⁴⁾
T ₂	Tank	ISO 6149	M33 x 2; 19 deep	3	O ⁴⁾
G	Synchronous control	ISO 6149	M14 x 1.5; 11.5 deep	500	X
U	Bearing flushing	ISO 6149	M22 x 1.5; 15.5 deep	3	X
X	Pilot signal (HP, HZ, HA1T/HA2T)	ISO 6149	M14 x 1.5; 11.5 deep	100	O
X	Pilot signal (HA1 and HA2)	ISO 6149	M14 x 1.5; 11.5 deep	3	X
X ₁ , X ₂	Pilot signal (DA0)	ISO 8434-1	SDSC-L8xM12-F	40	O
X ₁	Pilot signal (DA1, DA2)	ISO 6149	M14 x 1.5; 11.5 deep	40	O
X ₃	Pilot signal (DA1, DA2)	ISO 6149	M14 x 1.5; 11.5 deep	40	X
M ₁	Measuring, stroking chamber	ISO 6149	M14 x 1.5; 11.5 deep	500	X

1) Observe the general instructions on page 80 for the maximum tightening torques.

2) Short-term pressure spikes may occur depending on the application. Keep this in mind when selecting measuring devices and fittings.

3) Only dimensions according to SAE J518

4) Depending on installation position, T₁ or T₂ must be connected (see also page 76).

O = Must be connected (plugged on delivery)

X = Plugged (in normal operation)

Note

The ports and fixing threads are designed for the specified maximum pressure. The machine or system manufacturer must ensure that the connecting elements and lines correspond to the specified operating conditions (pressure, flow, hydraulic fluid, temperature) with the necessary safety factors.

Dimensions size 150

Before finalizing your design, request a binding installation drawing. Dimensions in mm.

EP1, EP2

Proportional control electric, positive control

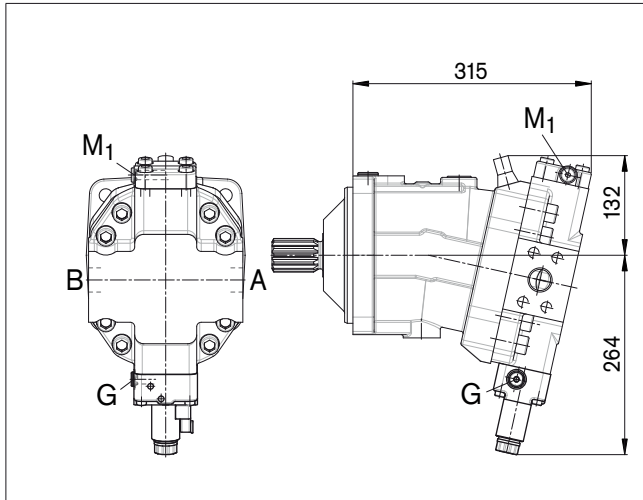

EP5D1, EP6D1

Proportional control electric, negative control, with pressure control, fixed setting

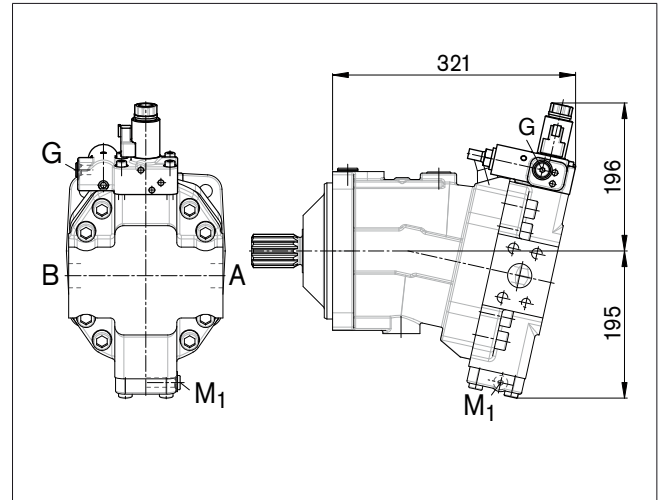

HP1, HP2

Proportional control hydraulic, positive control

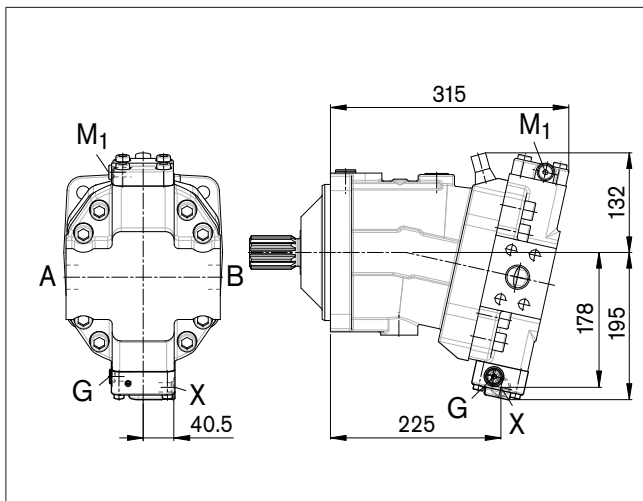

HP5, HP6

Proportional control hydraulic, negative control

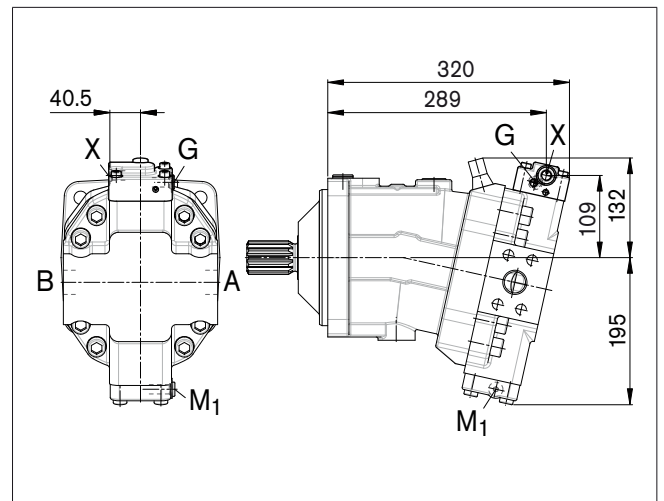

HP5D1, HP6D1

Proportional control hydraulic, negative control, with pressure control, fixed setting

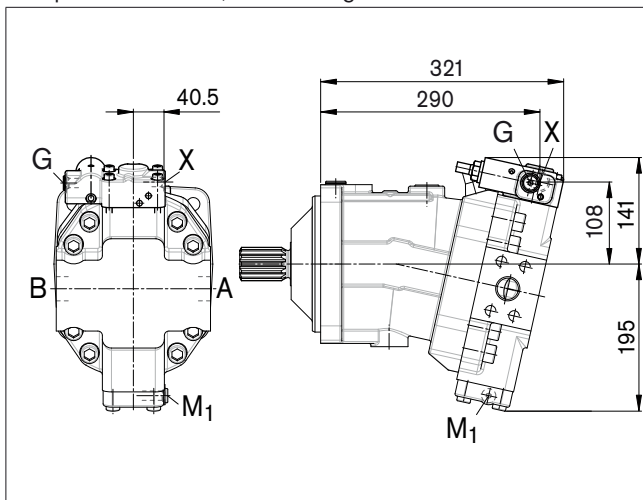

Dimensions size 150

Before finalizing your design, request a binding installation drawing. Dimensions in mm.

HZ5

Two-point control hydraulic, negative control

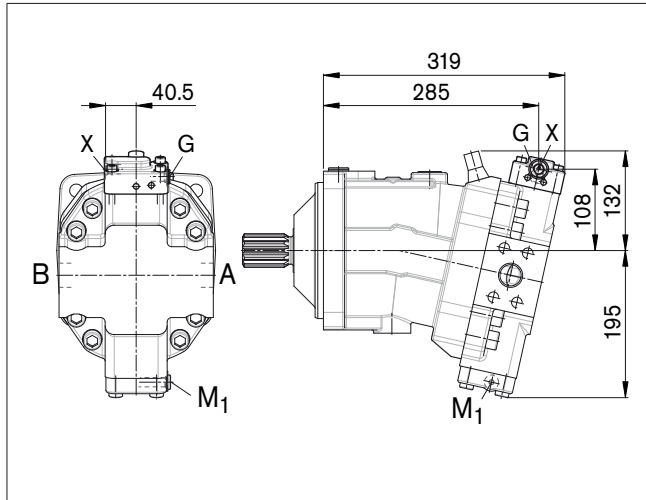

EZ5, EZ6

Two-point control electric, negative control

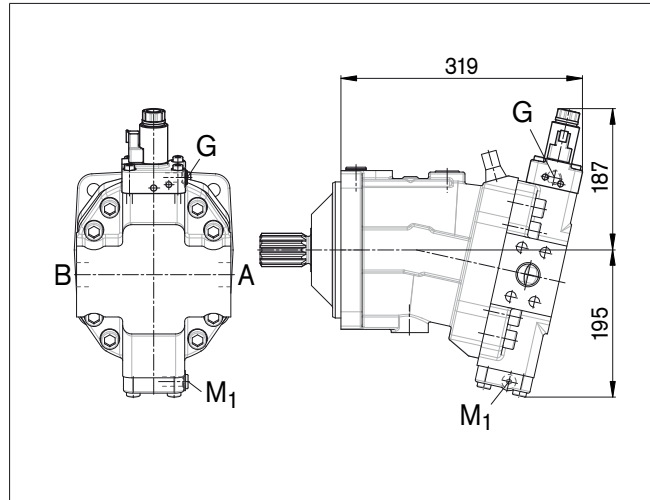

HA1, HA2 / HA1T3, HA2T3

Automatic control high-pressure related, positive control, with override, hydraulic remote control, proportional

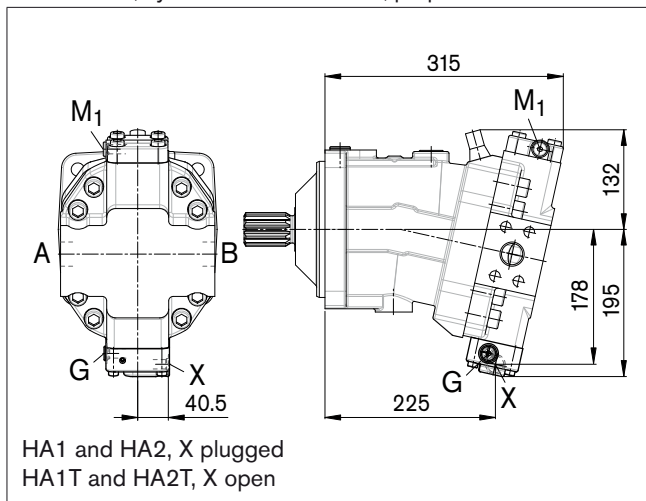

HA1U1, HA2U2

Automatic control high-pressure related, positive control, with override, electric, two-point

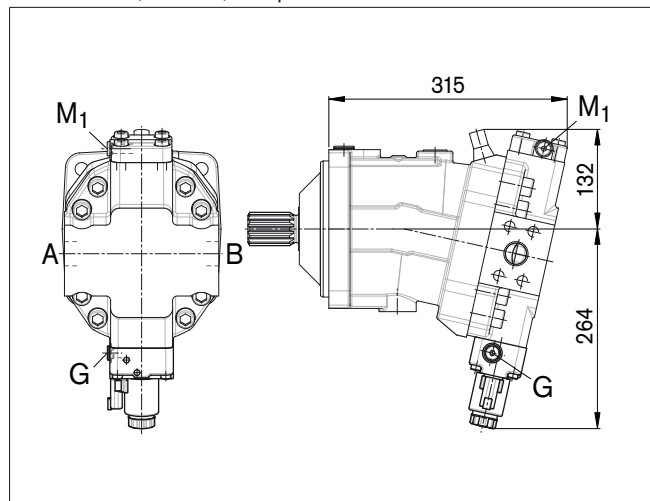

HA1R1, HA2R2

Automatic control high-pressure related, positive control, with override, electric and travel direction valve, electric

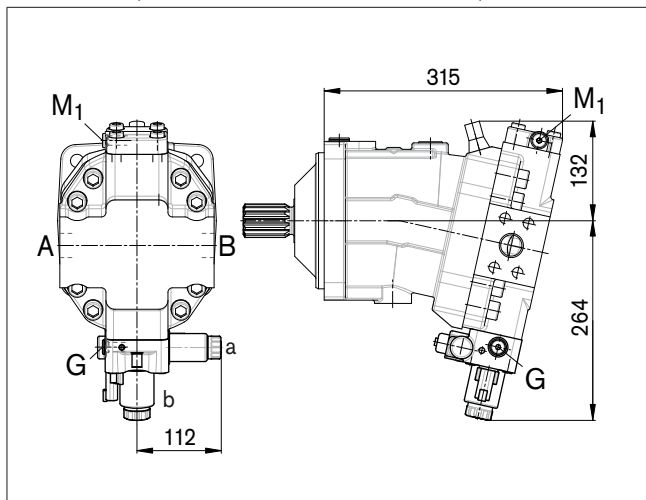

Dimensions size 150

Before finalizing your design, request a binding installation drawing. Dimensions in mm.

DA0

Automatic control speed related, negative control, hydraulic travel direction valve

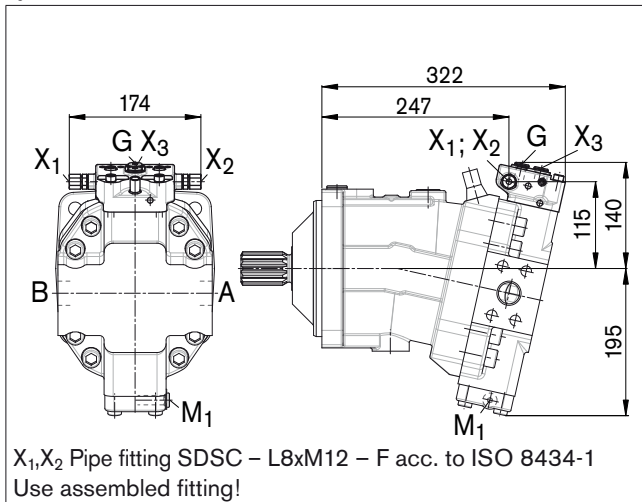

DA1, DA2

Automatic control speed related, negative control, electric travel direction valve and electric V_{G max} circuit

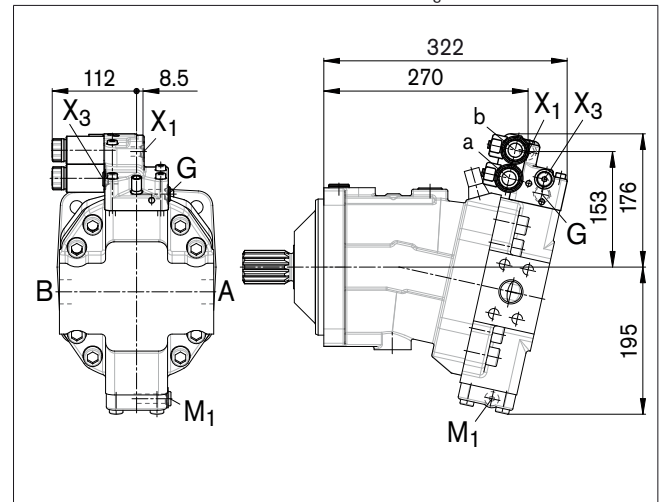

Dimensions size 170

Before finalizing your design, request a binding installation drawing. Dimensions in mm.

EP5, EP6 - Proportional control electric, negative control
 SAE flange ports A and B: at side, opposite (port plate 2)

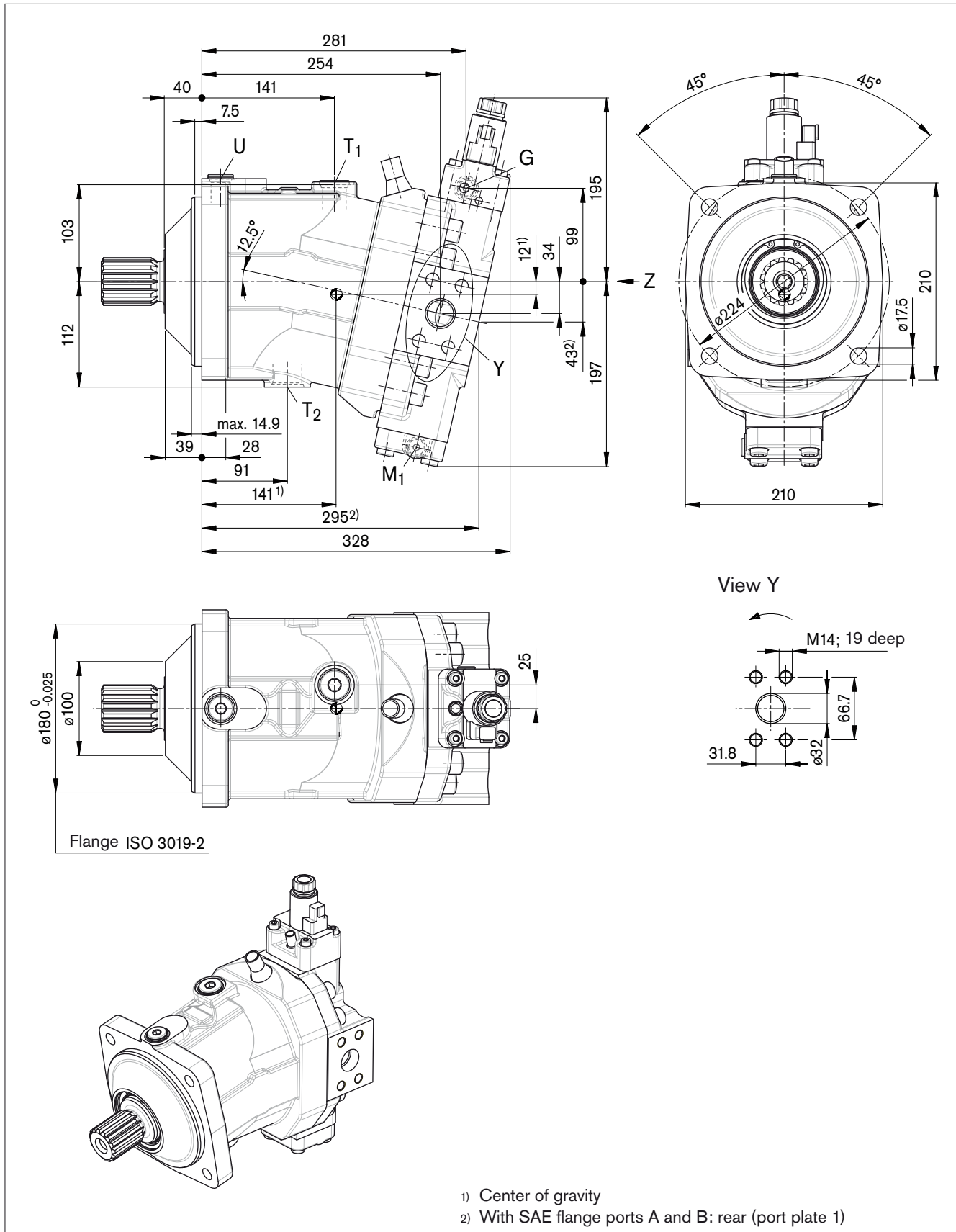

Dimensions size 170

Before finalizing your design, request a binding installation drawing. Dimensions in mm.

View Z

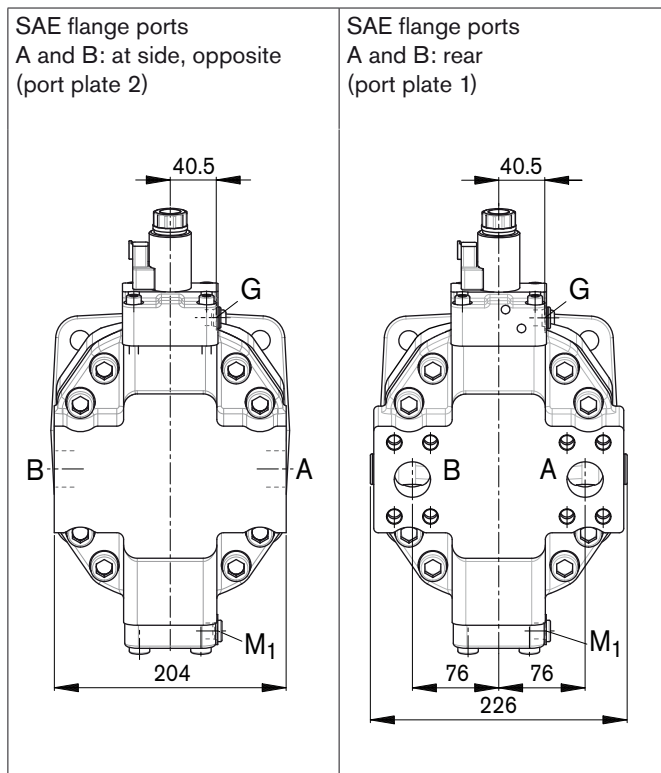

Drive shaft

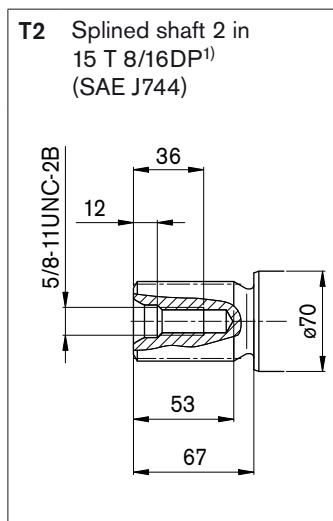

1) ANSI B92.1a-1976, 30° pressure angle, flat root, side fit, tolerance class 5

Dimensions size 170

Before finalizing your design, request a binding installation drawing. Dimensions in mm.

Ports

Designation	Port for	Standard	Size ¹⁾	Maximum pressure [bar] ²⁾	State
A, B	Service line, Fixing thread A/B	SAE J518 ³⁾ DIN 13	1 1/4 in M14 x 2; 19 deep	500	O
T ₁	Tank	ISO 6149	M27 x 2; 19 deep	3	X ⁴⁾
T ₂	Tank	ISO 6149	M33 x 2; 19 deep	3	O ⁴⁾
G	Synchronous control	ISO 6149	M14 x 1.5; 11.5 deep	500	X
U	Bearing flushing	ISO 6149	M22 x 1.5; 15.5 deep	3	X
X	Pilot signal (HP, HZ, HA1T/HA2T)	ISO 6149	M14 x 1.5; 11.5 deep	100	O
X	Pilot signal (HA1 and HA2)	ISO 6149	M14 x 1.5; 11.5 deep	3	X
X ₁ , X ₂	Pilot signal (DA0)	ISO 8434-1	SDSC-L8xM12-F	40	O
X ₁	Pilot signal (DA1, DA2)	ISO 6149	M14 x 1.5; 11.5 deep	40	O
X ₃	Pilot signal (DA1, DA2)	ISO 6149	M14 x 1.5; 11.5 deep	40	X
M ₁	Measuring, stroking chamber	ISO 6149	M14 x 1.5; 11.5 deep	500	X

1) Observe the general instructions on page 80 for the maximum tightening torques.

2) Short-term pressure spikes may occur depending on the application. Keep this in mind when selecting measuring devices and fittings.

3) Only dimensions according to SAE J518

4) Depending on installation position, T₁ or T₂ must be connected (see also page 76).

O = Must be connected (plugged on delivery)

X = Plugged (in normal operation)

Note

The ports and fixing threads are designed for the specified maximum pressure. The machine or system manufacturer must ensure that the connecting elements and lines correspond to the specified operating conditions (pressure, flow, hydraulic fluid, temperature) with the necessary safety factors.

Dimensions size 170

Before finalizing your design, request a binding installation drawing. Dimensions in mm.

EP1, EP2

Proportional control electric, positive control

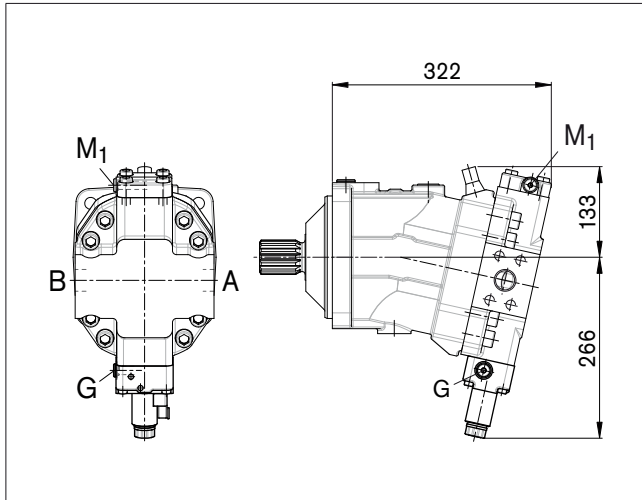

EP5D1, EP6D1

Proportional control electric, negative control, with pressure control, fixed setting

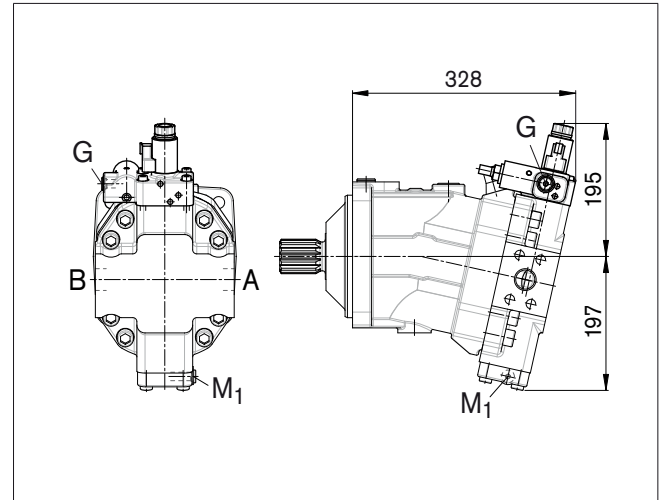

HP1, HP2

Proportional control hydraulic, positive control

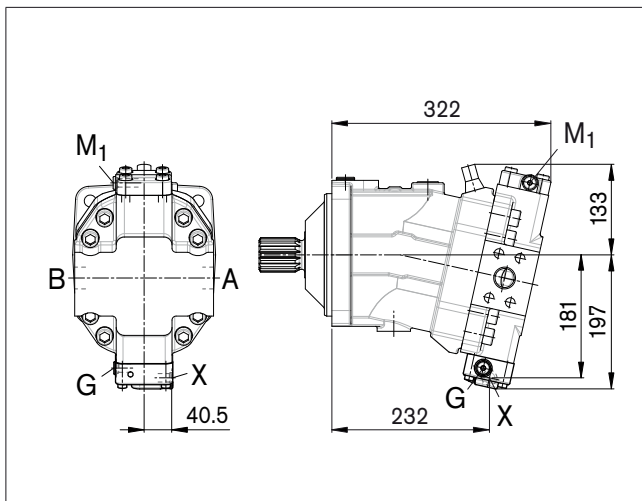

HP5, HP6

Proportional control hydraulic, negative control

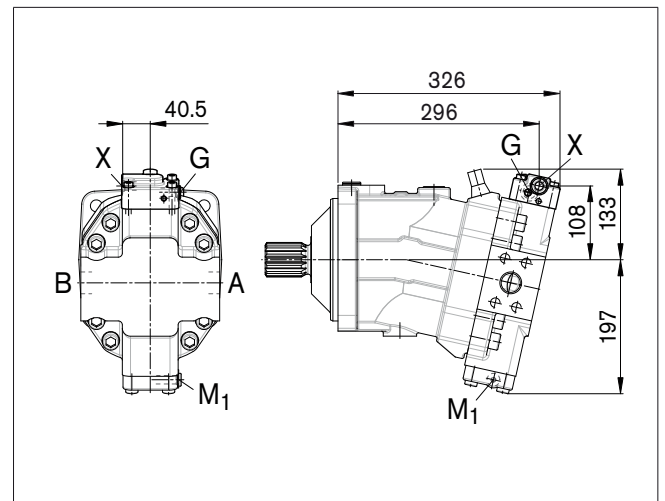

HP5D1, HP6D1

Proportional control hydraulic, negative control, with pressure control, fixed setting

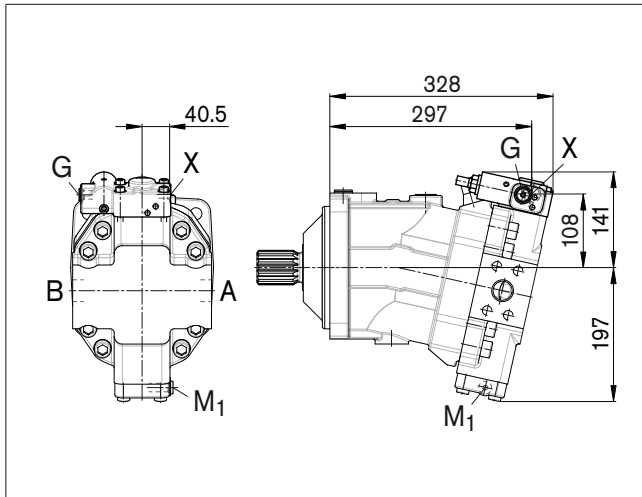

Dimensions size 170

Before finalizing your design, request a binding installation drawing. Dimensions in mm.

HZ5

Two-point control hydraulic, negative control

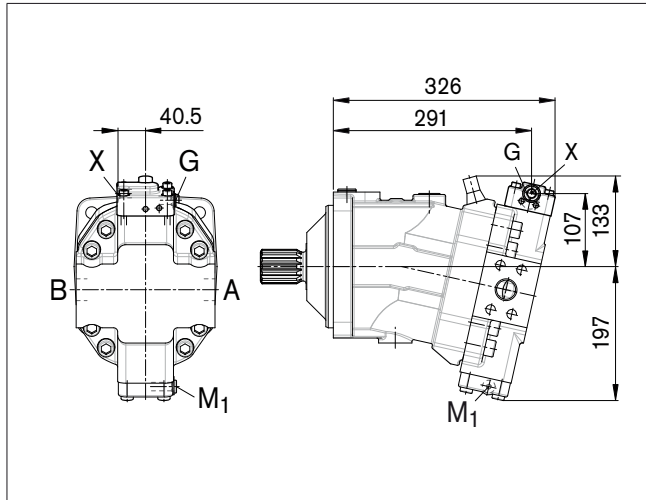

EZ5, EZ6

Two-point control electric, negative control

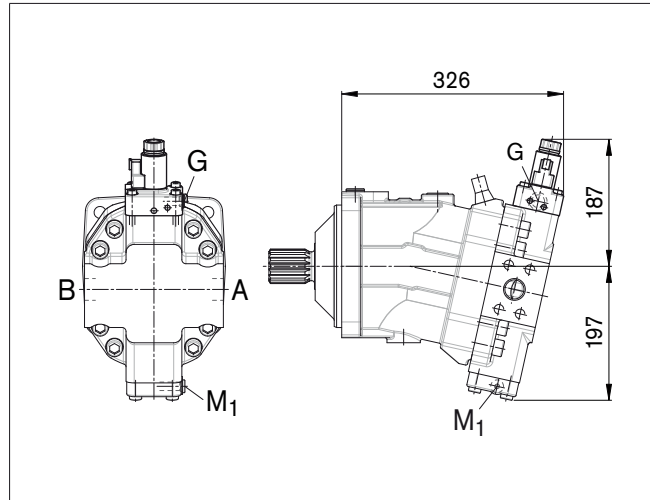

HA1, HA2 / HA1T3, HA2T3

Automatic control high-pressure related, positive control, with override, hydraulic remote control, proportional

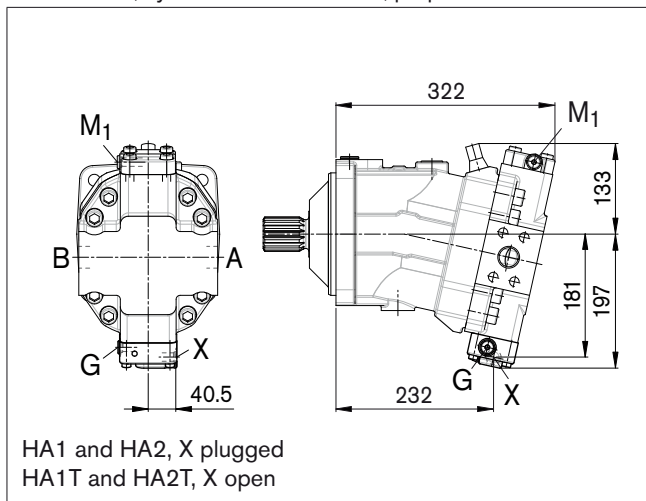

HA1 and HA2, X plugged
HA1T and HA2T, X open

HA1U1, HA2U2

Automatic control high-pressure related, positive control, with override, electric, two-point

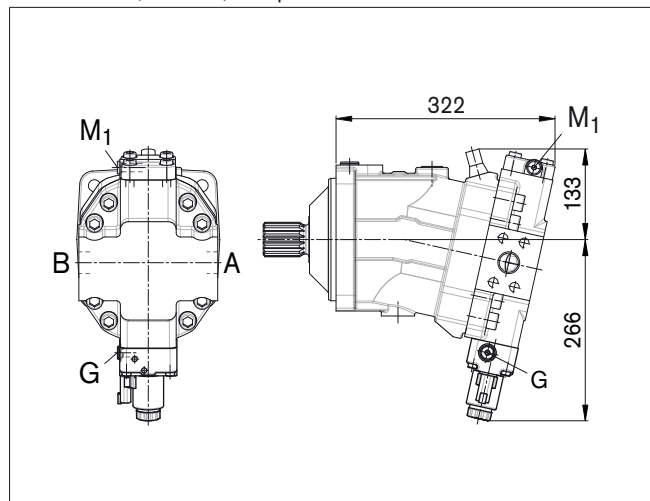

HA1R1, HA2R2

Automatic control high-pressure related, positive control, with override, electric and travel direction valve, electric

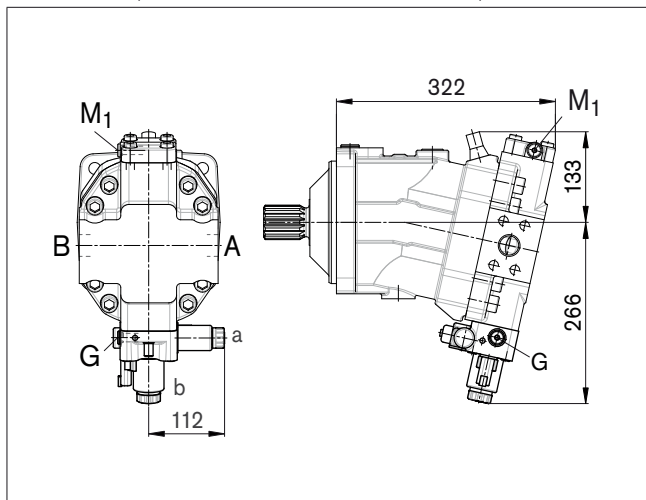

Dimensions size 170

Before finalizing your design, request a binding installation drawing. Dimensions in mm.

DA0

Automatic control speed related, negative control, hydraulic travel direction valve

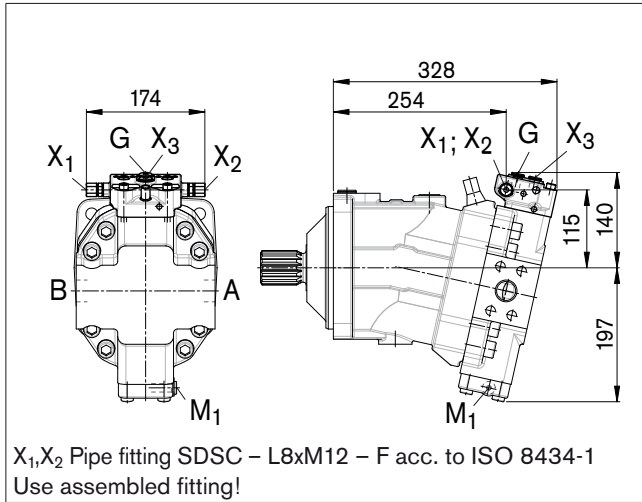

DA1, DA2

Automatic control speed related, negative control, electric travel direction valve and electric V_{G max} circuit

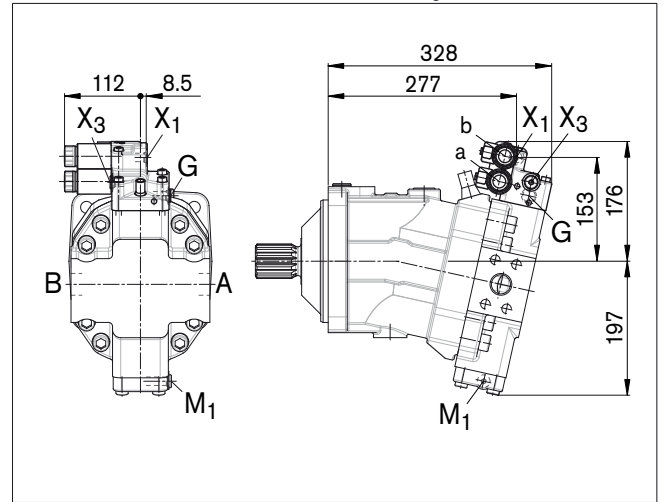

Dimensions size 215

Before finalizing your design, request a binding installation drawing. Dimensions in mm.

EP5, EP6 - Proportional control electric, negative control
 SAE flange ports A and B: at side, opposite (port plate 2)

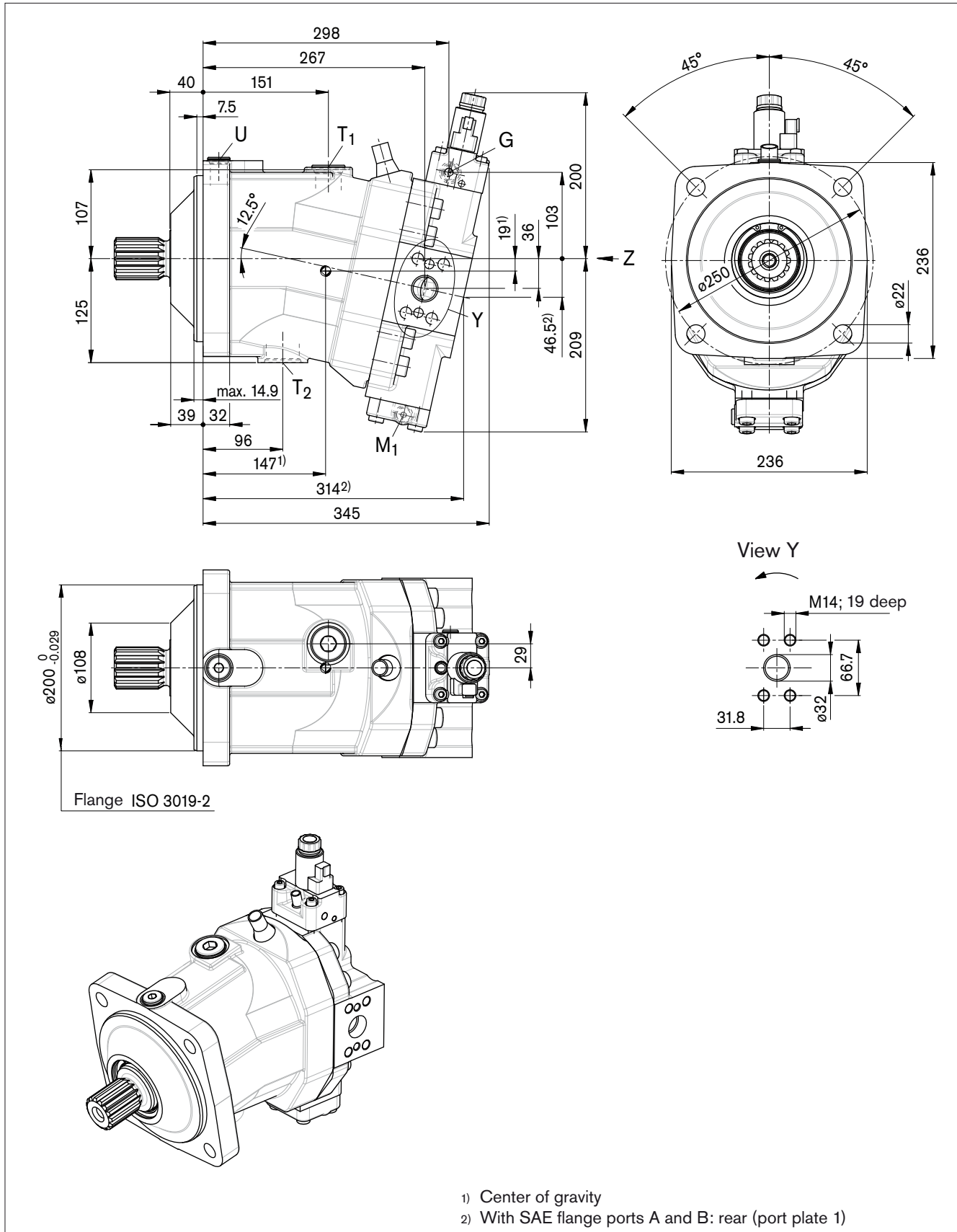

Dimensions size 215

Before finalizing your design, request a binding installation drawing. Dimensions in mm.

View Z

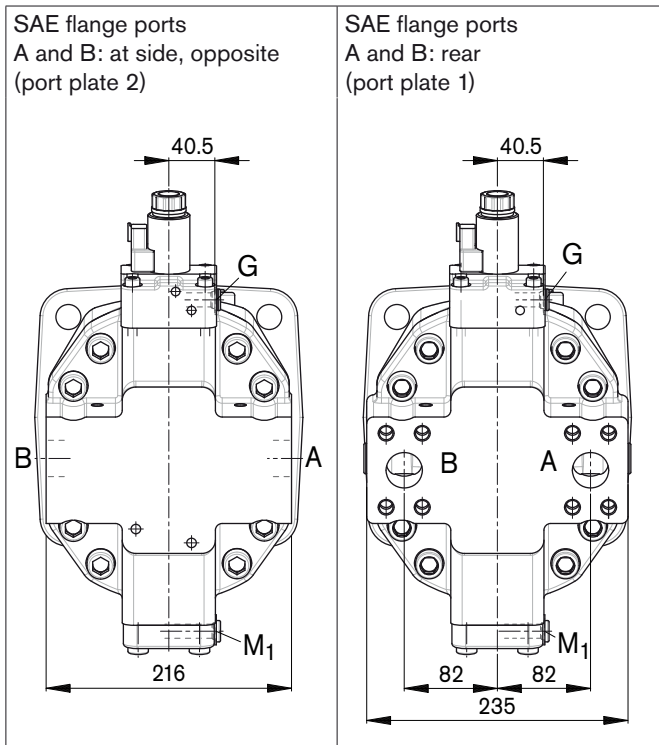

Drive shaft

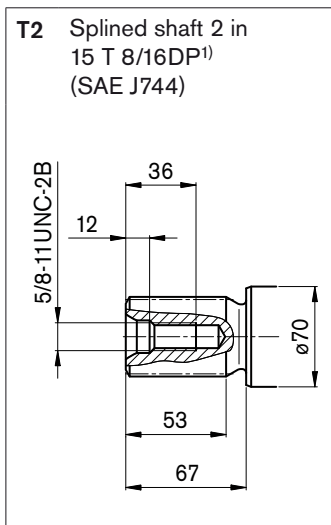

1) ANSI B92.1a-1976, 30° pressure angle, flat root, side fit, tolerance class 5

Dimensions size 215

Before finalizing your design, request a binding installation drawing. Dimensions in mm.

Ports

Designation	Port for	Standard	Size ¹⁾	Maximum pressure [bar] ²⁾	State
A, B	Service line, Fixing thread A/B	SAE J518 ³⁾ DIN 13	1 1/4 in M14 x 2; 19 deep	500	O
T ₁	Tank	ISO 6149	M33 x 2; 19 deep	3	X ⁴⁾
T ₂	Tank	ISO 6149	M42 x 2; 19.5 deep	3	O ⁴⁾
G	Synchronous control	ISO 6149	M14 x 1.5; 11.5 deep	500	X
U	Bearing flushing	ISO 6149	M22 x 1.5; 15.5 deep	3	X
X	Pilot signal (HP, HZ, HA1T/HA2T)	ISO 6149	M14 x 1.5; 11.5 deep	100	O
X	Pilot signal (HA1 and HA2)	ISO 6149	M14 x 1.5; 11.5 deep	3	X
X ₁ , X ₂	Pilot signal (DA0)	ISO 8434-1	SDSC-L8xM12-F	40	O
X ₁	Pilot signal (DA1, DA2)	ISO 6149	M14 x 1.5; 11.5 deep	40	O
X ₃	Pilot signal (DA1, DA2)	ISO 6149	M14 x 1.5; 11.5 deep	40	X
M ₁	Measuring, stroking chamber	ISO 6149	M14 x 1.5; 11.5 deep	500	X

1) Observe the general instructions on page 80 for the maximum tightening torques.

2) Short-term pressure spikes may occur depending on the application. Keep this in mind when selecting measuring devices and fittings.

3) Only dimensions according to SAE J518

4) Depending on installation position, T₁ or T₂ must be connected (see also page 76).

O = Must be connected (plugged on delivery)

X = Plugged (in normal operation)

Note

The ports and fixing threads are designed for the specified maximum pressure. The machine or system manufacturer must ensure that the connecting elements and lines correspond to the specified operating conditions (pressure, flow, hydraulic fluid, temperature) with the necessary safety factors.

Dimensions size 215

Before finalizing your design, request a binding installation drawing. Dimensions in mm.

EP1, EP2

Proportional control electric, positive control

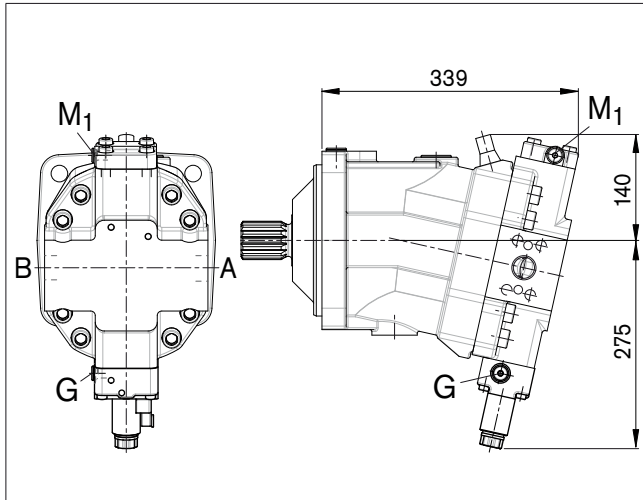

EP5D1, EP6D1

Proportional control electric, negative control, with pressure control, fixed setting

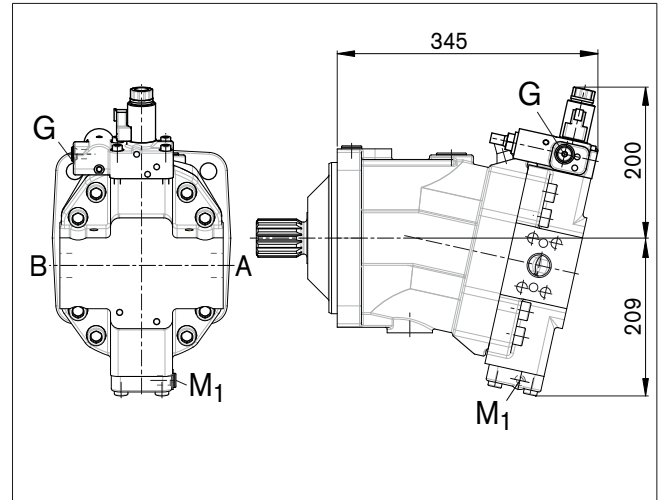

HP1, HP2

Proportional control hydraulic, positive control

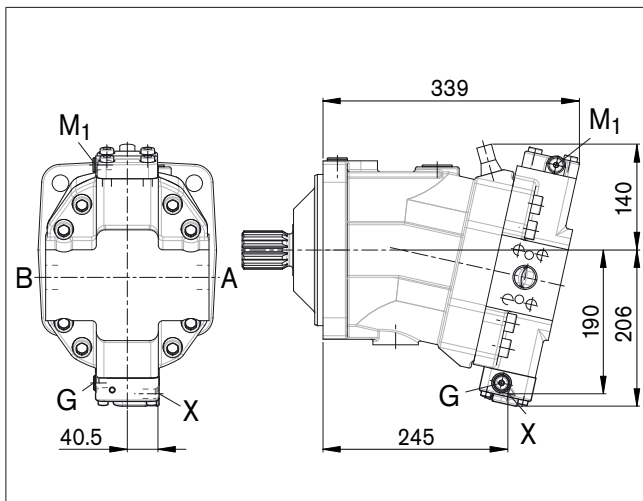

HP5, HP6

Proportional control hydraulic, negative control

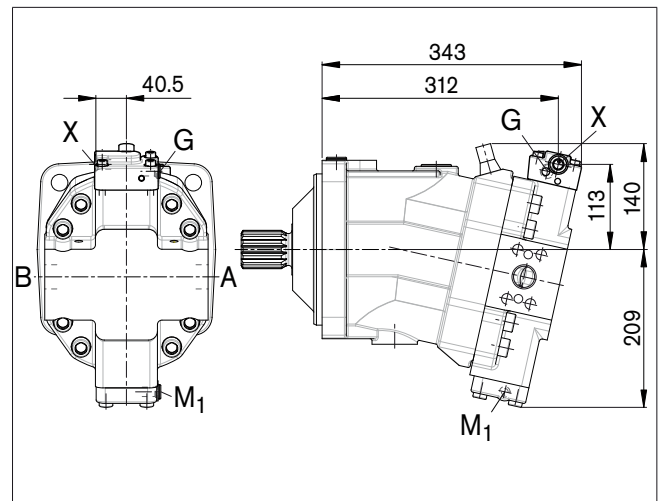

HP5D1, HP6D1

Proportional control hydraulic, negative control, with pressure control, fixed setting

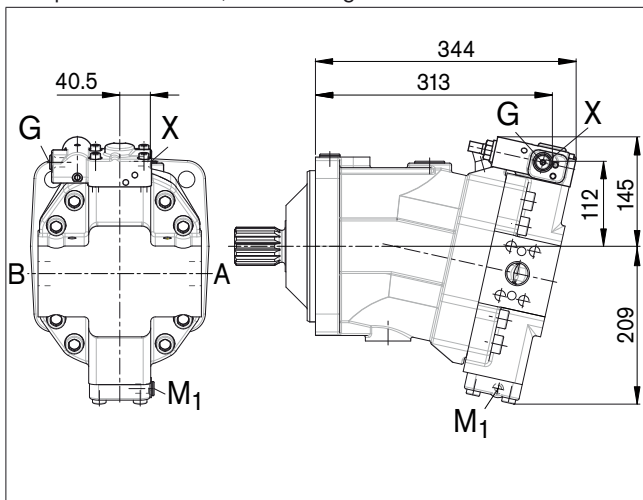

Dimensions size 215

Before finalizing your design, request a binding installation drawing. Dimensions in mm.

HZ5

Two-point control hydraulic, negative control

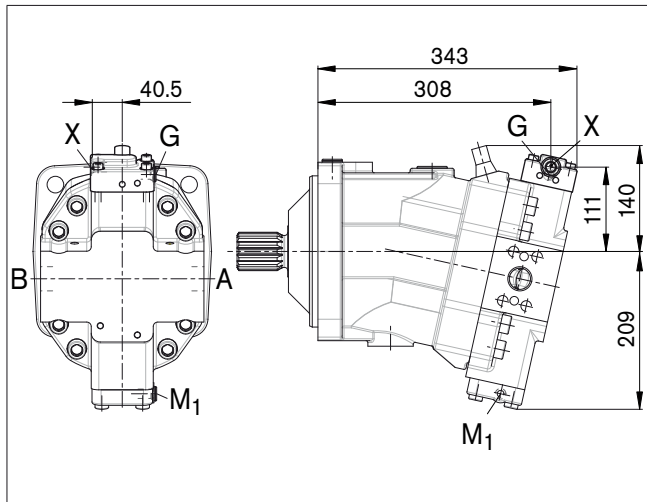

EZ5, EZ6

Two-point control electric, negative control

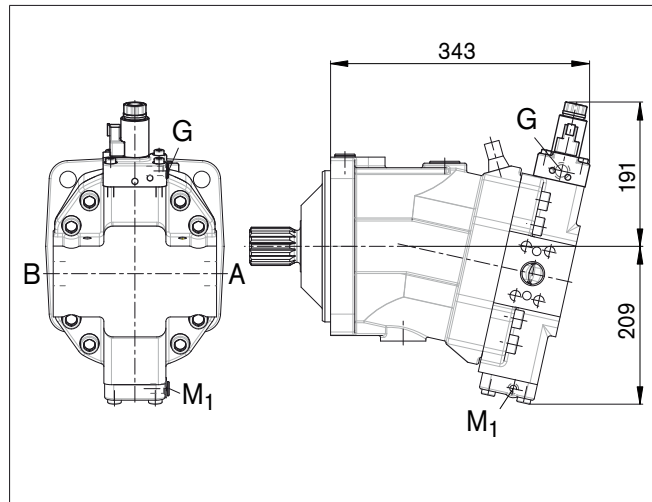

HA1, HA2 / HA1T3, HA2T3

Automatic control high-pressure related, positive control, with override, hydraulic remote control, proportional

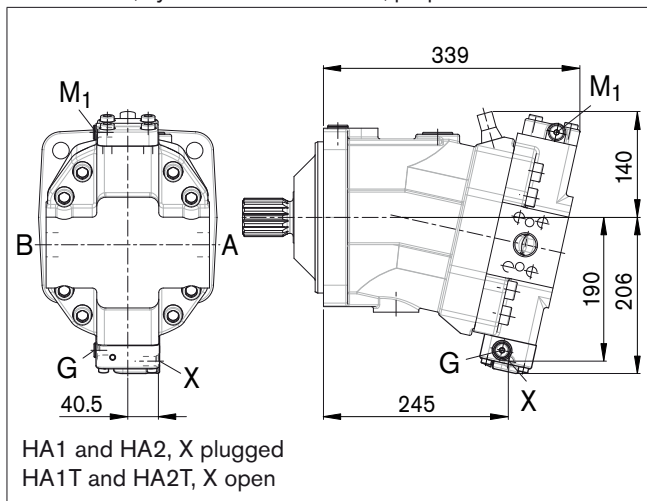

HA1U1, HA2U2

Automatic control high-pressure related, positive control, with override, electric, two-point

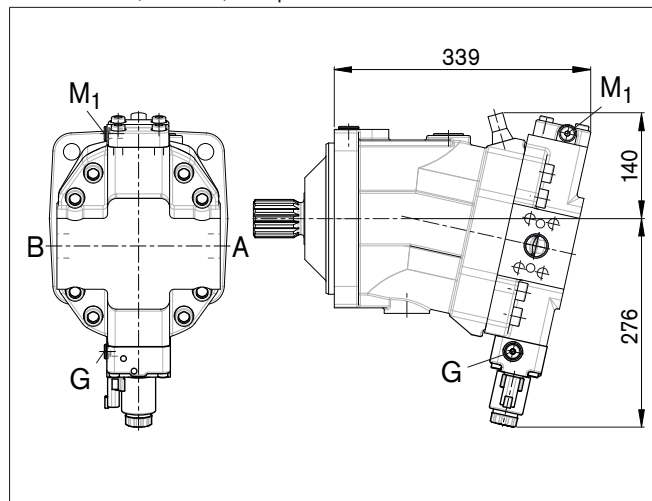

HA1R1, HA2R2

Automatic control high-pressure related, positive control, with override, electric and travel direction valve, electric

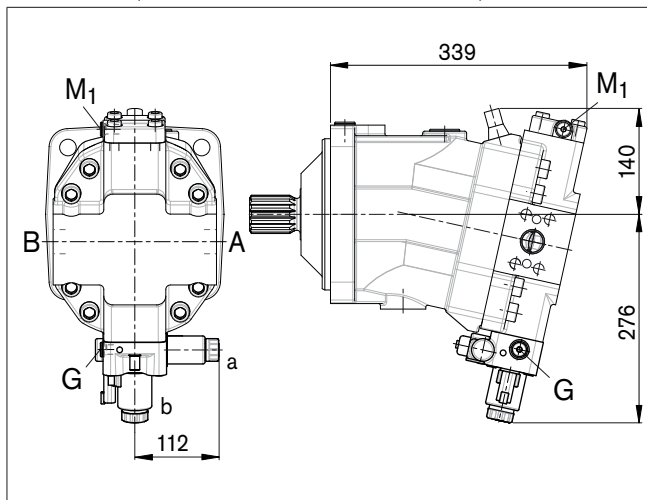

Dimensions size 215

Before finalizing your design, request a binding installation drawing. Dimensions in mm.

DA0

Automatic control speed related, negative control, hydraulic travel direction valve

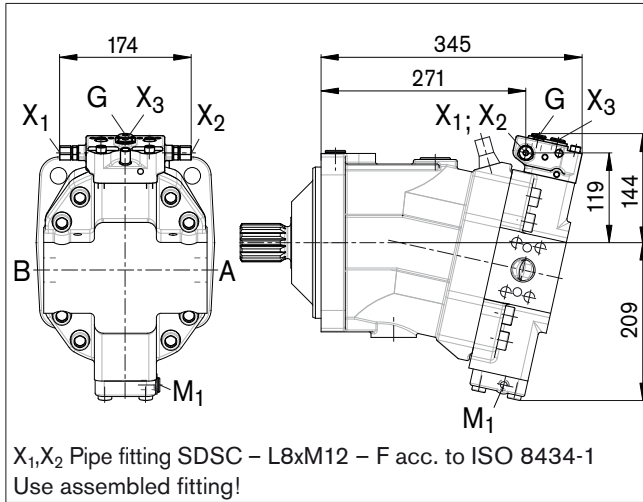

DA1, DA2

Automatic control speed related, negative control, electric travel direction valve and electric V_{G max}- circuit

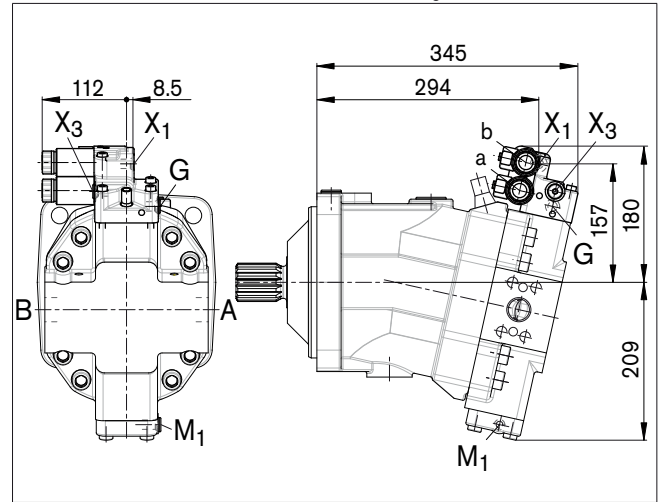

Dimensions size 280

Before finalizing your design, request a binding installation drawing. Dimensions in mm.

EP5, EP6 - Proportional control electric, negative control
 SAE flange ports A and B: at side, opposite (port plate 2)

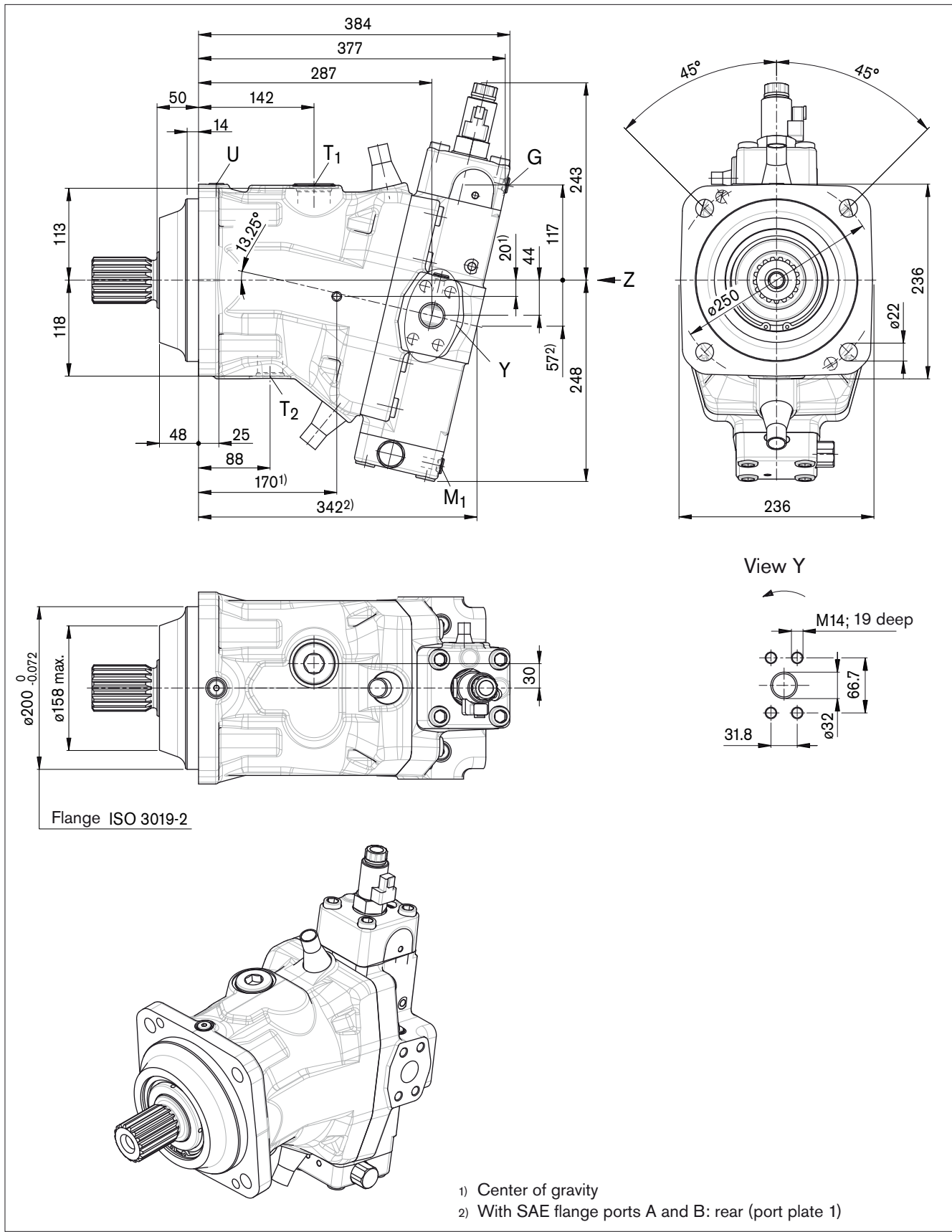

Dimensions size 280

Before finalizing your design, request a binding installation drawing. Dimensions in mm.

View Z

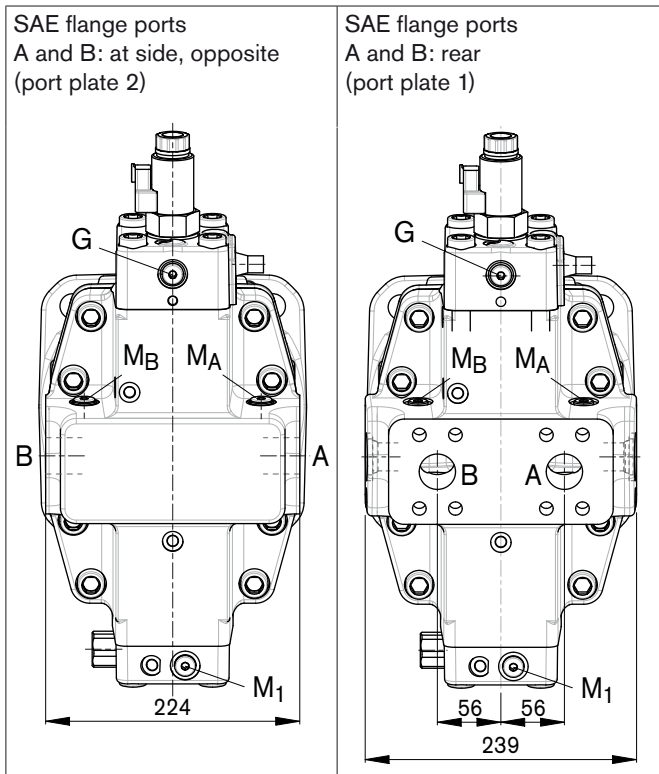

Drive shaft

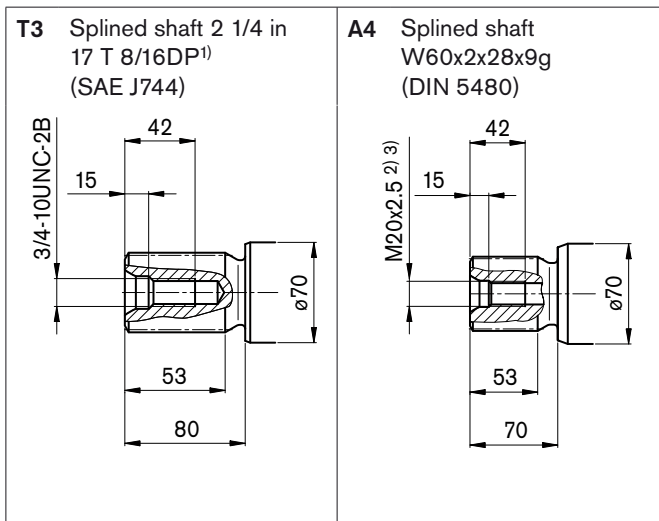

- 1) ANSI B92.1a-1976, 30° pressure angle, flat root, side fit, tolerance class 5
- 2) Center bore according to DIN 332 (thread according to DIN 13)
- 3) Observe the general instructions on page 80 for the maximum tightening torques.

Dimensions size 280

Before finalizing your design, request a binding installation drawing. Dimensions in mm.

Ports

Designation	Port for	Standard	Size ¹⁾	Maximum pressure [bar] ²⁾	State
A, B	Service line, Fixing thread A/B	SAE J518 ³⁾ DIN 13	1 1/4 in M14 x 2; 19 deep	500	O
T ₁	Tank	ISO 6149	M42 x 2; 19.5 deep	3	O ⁴⁾
T ₂	Tank	ISO 6149	M33 x 2; 19 deep	3	X ⁴⁾
G	Synchronous control	ISO 6149	M14 x 1.5; 11.5 deep	500	X
U	Bearing flushing	ISO 6149	M14 x 1.5; 11.5 deep	3	X
M ₁	Measuring, stroking chamber	ISO 6149	M14 x 1.5; 11.5 deep	500	X
M _A	Measuring, pressure A	ISO 6149	M14 x 1.5; 11.5 deep	500	X
M _B	Measuring, pressure B	ISO 6149	M14 x 1.5; 11.5 deep	500	X

1) Observe the general instructions on page 80 for the maximum tightening torques.

2) Short-term pressure spikes may occur depending on the application. Keep this in mind when selecting measuring devices and fittings.

3) Only dimensions according to SAE J518

4) Depending on installation position, T₁ or T₂ must be connected (see also page 76).

O = Must be connected (plugged on delivery)

X = Plugged (in normal operation)

Note

The ports and fixing threads are designed for the specified maximum pressure. The machine or system manufacturer must ensure that the connecting elements and lines correspond to the specified operating conditions (pressure, flow, hydraulic fluid, temperature) with the necessary safety factors.

Dimensions size 280

Before finalizing your design, request a binding installation drawing. Dimensions in mm.

EP1, EP2

Proportional control electric, positive control

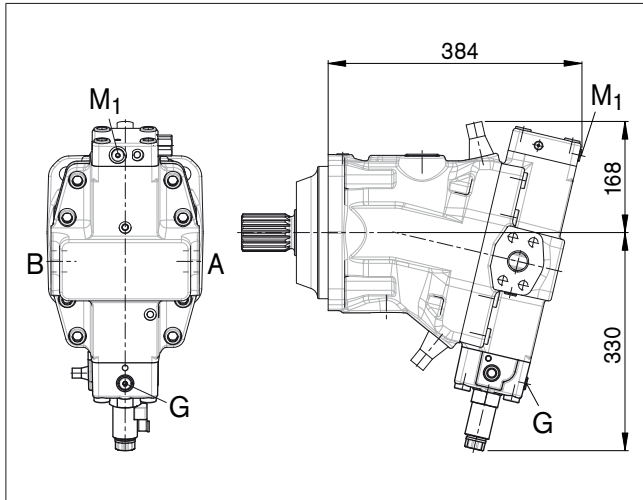

EP5D1, EP6D1

Proportional control electric, negative control, with pressure control, fixed setting

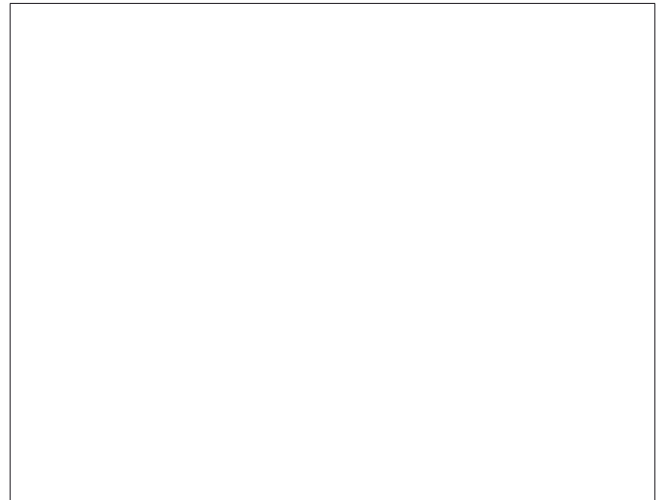

HP1, HP2

Proportional control hydraulic, positive control

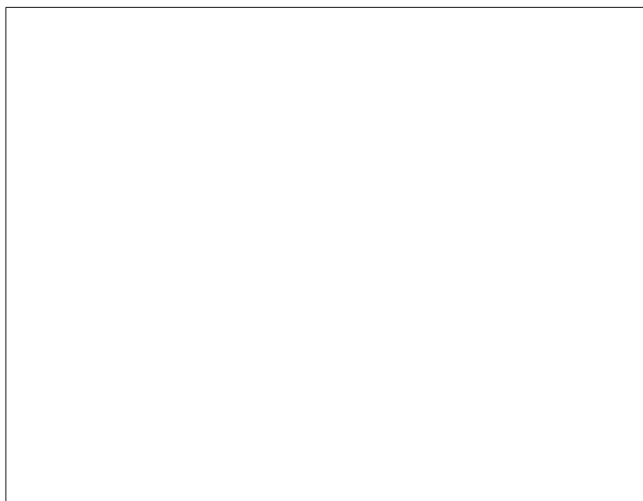

HP5, HP6

Proportional control hydraulic, negative control

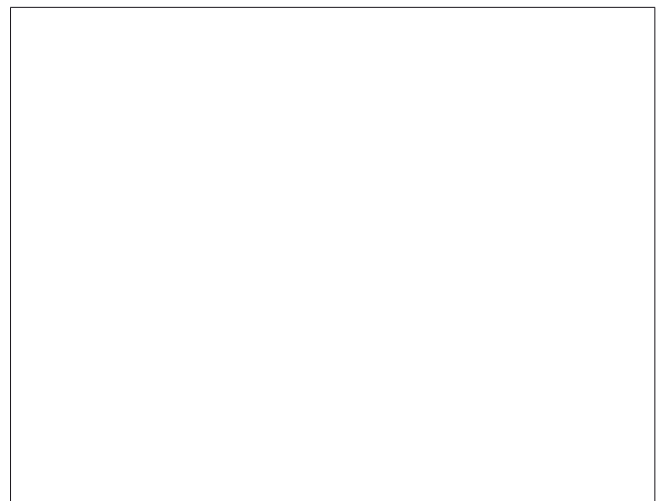

HP5D1, HP6D1

Proportional control hydraulic, negative control, with pressure control, fixed setting

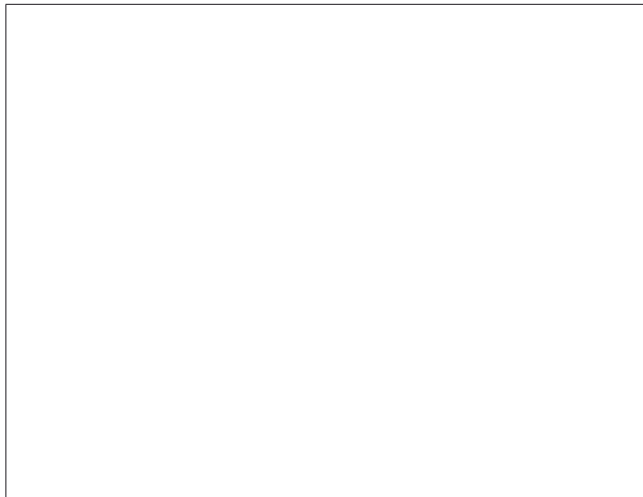

Dimensions size 280

Before finalizing your design, request a binding installation drawing. Dimensions in mm.

HZ5

Two-point control hydraulic, negative control

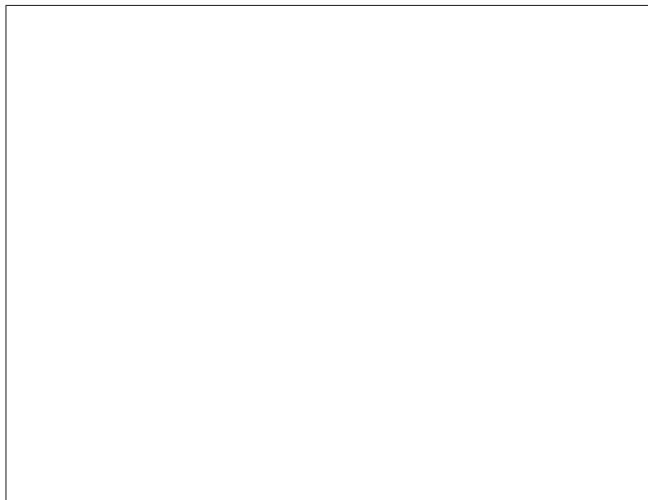

EZ5, EZ6

Two-point control electric, negative control

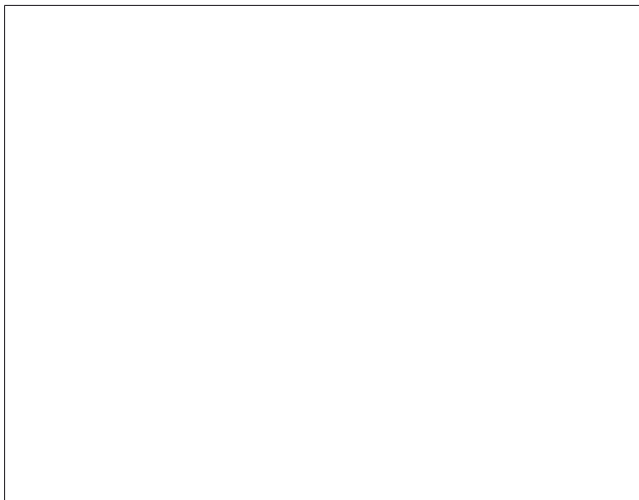

HA1, HA2 / HA1T3, HA2T3

Automatic control high-pressure related, positive control, with override, hydraulic remote control, proportional

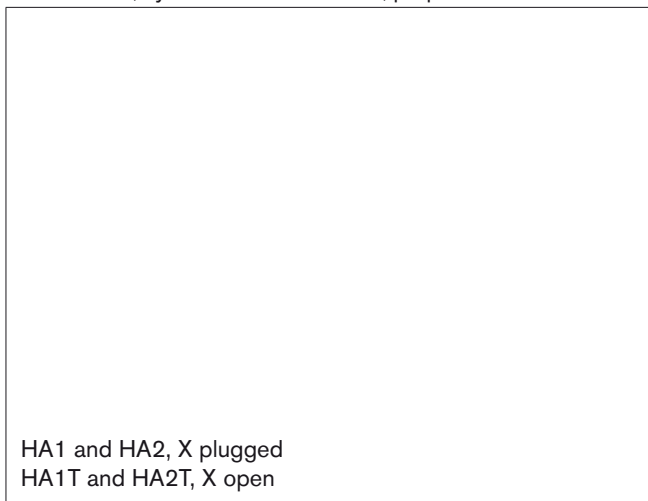

Connector for solenoids

Before finalizing your design, request a binding installation drawing. Dimensions in mm.

DEUTSCH DT04-2P-EP04, 2-pin

Molded, without bidirectional suppressor diode _____ P

Type of protection according to DIN/EN 60529:
IP67 and IP69K

Circuit symbol

Without bidirectional suppressor diode

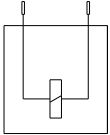

Mating connector

DEUTSCH DT06-2S-EP04
Rexroth Mat. No. R902601804

Consisting of: _____ DT designation

– 1 case _____ DT06-2S-EP04

– 1 wedge _____ W2S

– 2 female connectors _____ 0462-201-16141

The mating connector is not included in the delivery contents.
This can be supplied by Rexroth on request.

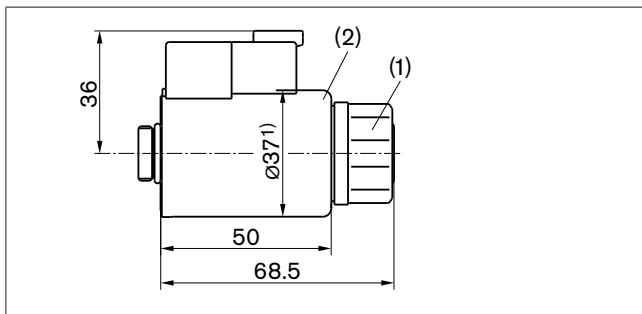

1) Solenoid with $\varnothing 45$ for following controls: HA.U, HA.R (for electric override), EZ7 and EZ8.

Changing connector position

If necessary, you can change the position of the connector by turning the solenoid.

To do this, proceed as follows:

1. Loosen the fixing nut (1) of the solenoid. To do this, turn the fixing nut (1) one turn counter-clockwise.
2. Turn the solenoid body (2) to the desired position.
3. Retighten the fixing nut. Tightening torque of the fixing nut:
 5 ± 1 Nm (WAF26, 12-sided DIN 3124)

On delivery, the position of the connector may differ from that shown in the brochure or drawing.

Setting range for displacement

		60				85				115				150			
	$V_{g \max}$ [cm ³ /rev]		$V_{g \min}$ [cm ³ /rev]		$V_{g \max}$ [cm ³ /rev]		$V_{g \min}$ [cm ³ /rev]		$V_{g \max}$ [cm ³ /rev]		$V_{g \min}$ [cm ³ /rev]		$V_{g \max}$ [cm ³ /rev]		$V_{g \min}$ [cm ³ /rev]		
	from	to	from	to	from	to	from	to	from	to	from	to	from	to	from	to	
A	62.0	62.0	0.0	15.0	85.2	85.2	0.0	31.5	115.6	115.6	0.0	24.0	152.0	152.0	0.0	44.0	
	without screw		M10x60 R909154690		without screw		M12x70 R909085976		without screw		M12x70 R909085976		without screw		M12x80 R909153075		
B	62.0	62.0	> 15.0	30.5	85.2	85.2	> 31.5	52.0	115.6	115.6	> 24.0	47.5	152.0	152.0	> 44.0	69.0	
	without screw		M10x70 R909153779		without screw		M12x80 R909153075		without screw		M12x80 R909153075		without screw		M12x90 R909154041		
E	< 62.0	47.5	0.0	15.0	< 85.2	55.5	0.0	31.5	< 115.6	93.5	0.0	24.0	< 152.0	111.0	0.0	44.0	
	M10x60 R909154690		M10x60 R909154690		M12x70 R909085976		M12x70 R909085976		M12x70 R909085976		M12x70 R909085976		M12x80 R909153075		M12x80 R909153075		
F	< 62.0	47.5	> 15.0	30.5	< 85.2	55.5	> 31.5	52.0	< 115.6	93.5	> 24.0	47.5	< 152.0	111.0	> 44.0	69.0	
	M10x60 R909154690		M10x70 R909153779		M12x70 R909085976		M12x80 R909153075		M12x70 R909085976		M12x80 R909153075		M12x80 R909153075		M12x90 R909154041		

		170				215				280			
	$V_{g \max}$ [cm ³ /rev]		$V_{g \min}$ [cm ³ /rev]		$V_{g \max}$ [cm ³ /rev]		$V_{g \min}$ [cm ³ /rev]		$V_{g \max}$ [cm ³ /rev]		$V_{g \min}$ [cm ³ /rev]		
	from	to	from	to	from	to	from	to	from	to	from	to	
A	172.0	172.0	0.0	35.0	216.5	216.5	0.0	44.5					
	without screw		M12x80 R909153075		without screw		M12x80 R909153075		x		x		
B	172.0	172.0	> 35.0	63.5	216.5	216.5	> 44.5	80.0					
	without screw		M12x90 R909154041		without screw		M12x90 R909154041		x		x		
E	< 172.0	139.0	0.0	35.0	< 216.5	175.0	0.0	44.5	280.1	230.0	0.0	55.0	
	M12x80 R909153075		M12x80 R909153075		M12x80 R909153075		M12x80 R909153075		M16x100 R910909811		M16x100 R910909811		
F	< 172.0	139.0	> 35.0	63.5	< 216.5	175.0	> 44.5	80.0	280.1	230.0	> 55.0	98.0	
	M12x80 R909153075		M12x90 R909154041		M12x80 R909153075		M12x90 R909154041		M16x100 R910909811		M16x110 R910909719		

Specify exact setting for $V_{g \min}$ and $V_{g \max}$ in plain text when ordering:

$V_{g \min} = \dots \text{ cm}^3$, $V_{g \max} = \dots \text{ cm}^3$

Maximum setting $V_{g \min} = 0.7 \times V_{g \max}$

Maximum setting $V_{g \max} = 0.3 \times V_{g \max}$

These settings must not be exceeded, as damage may otherwise result.

Flush and boost pressure valve

The flush and boost pressure valve is used to remove heat from the hydraulic circuit.

In an open circuit, it is used exclusively for flushing the case.

In a closed circuit, the minimum boost pressure is also limited in addition to the case flushing.

Hydraulic fluid is directed from the respective low pressure side into the motor case. This is then fed into the tank, together with the case drain fluid. The hydraulic fluid drawn out of the closed circuit must be replaced by cooled hydraulic fluid that is supplied by the boost pump.

The valve is mounted on the port plate or integrated (depending on the control type and size).

Opening pressure (observe when adjusting the primary valve):

- Sizes 60 to 215: 16 bar, fixed setting
- Size 280: 15 to 35 bar, adjustable (flushing flow up to 60 l/min possible, please contact us)

Orifices can be used to adjust the flushing flows as required.

Flushing flow, sizes 60 to 115

Small flushing valve

Material number $\Delta p_{ND} = p_{ND} - p_G = 25 \text{ bar}$ and
 $v = 10 \text{ mm}^2/\text{s}$ ($p_G = \text{case pressure}$)

R909651766	3.5
R909419695	5
R909419696	8
R909419697	10
R909444361	14

Flushing flow, size 115

Medium flushing valve

Material number $\Delta p_{ND} = p_{ND} - p_G = 25 \text{ bar}$ and
 $v = 10 \text{ mm}^2/\text{s}$ ($p_G = \text{case pressure}$)

R909431310	20
R909435172	25
R909449967	30

Flushing flow, sizes 150 to 215

Large flushing valve

Material number $\Delta p_{ND} = p_{ND} - p_G = 25 \text{ bar}$ and
 $v = 10 \text{ mm}^2/\text{s}$ ($p_G = \text{case pressure}$)

R909449998	8
R909431308	10
R909431309	17
R909431310	20
R902138235	25
R909435172	30
R909436622	35
R909449967	40

For a flushing flow greater than 35 l/min, it is recommended that port S_a be connected in order to prevent an increase in the case internal pressure. An increased case internal pressure reduces the flushing flow.

Circuit diagram EP

Sizes 60 to 215

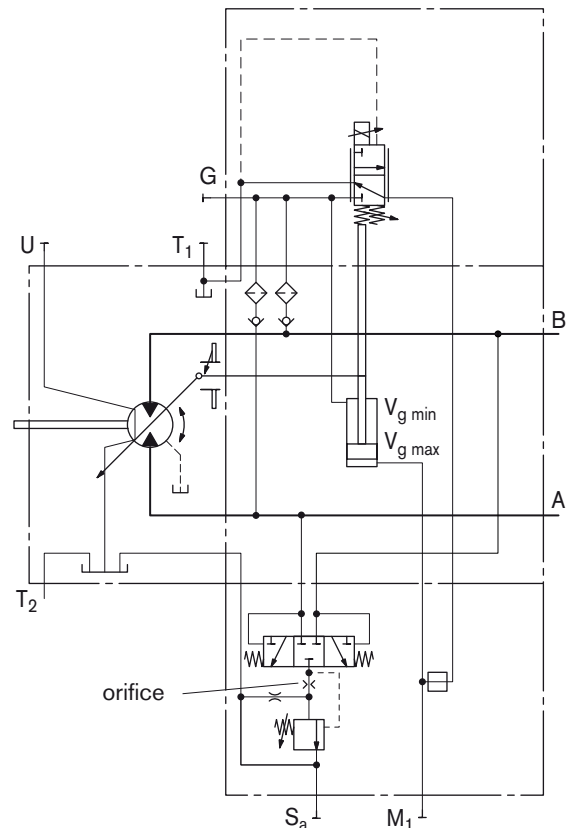

Port S_a only for sizes 150 to 215.

Circuit diagram EP

Size 280

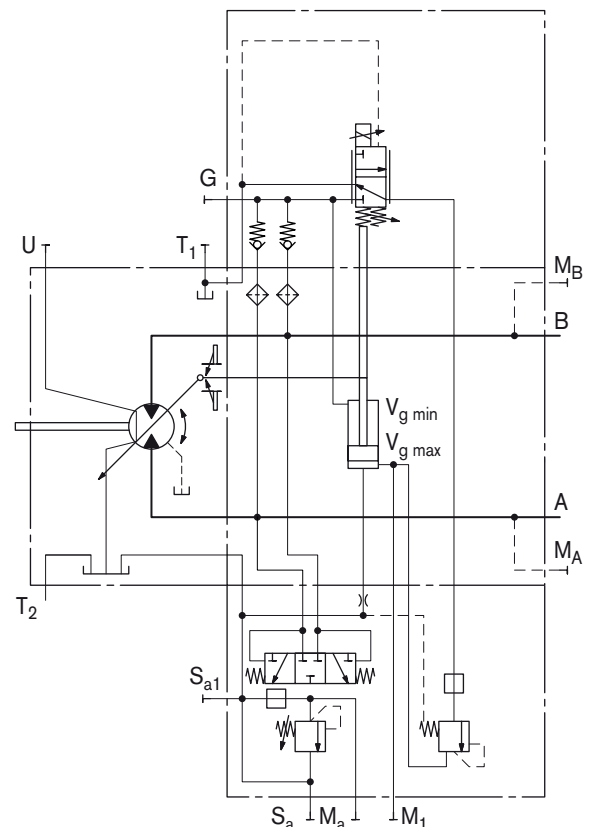

Flush and boost pressure valve

Before finalizing your design, request a binding installation drawing. Dimensions in mm.

Dimension, sizes 60 to 115

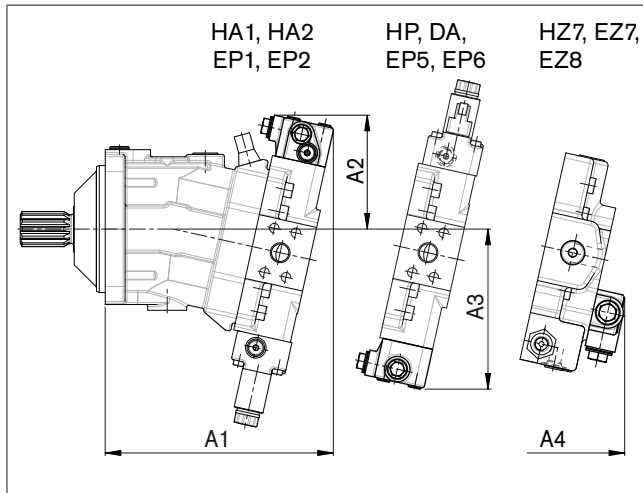

NG	A1	A2	A3	A4
060	243	133	176	236
085	273	142	194	254
115	287	143	202	269

Dimensions size 115 (large flushing valve)

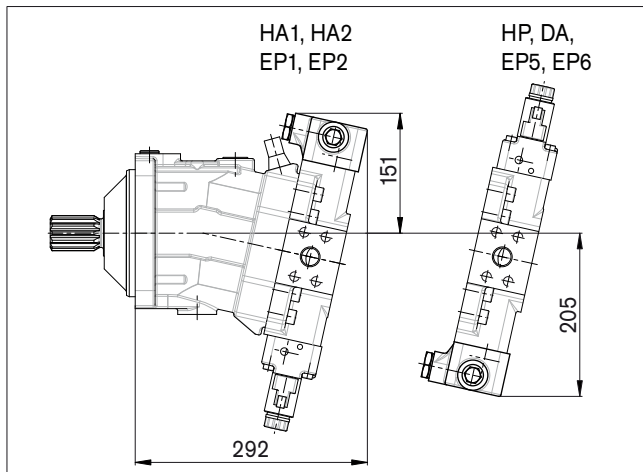

Dimensions sizes 150 to 215

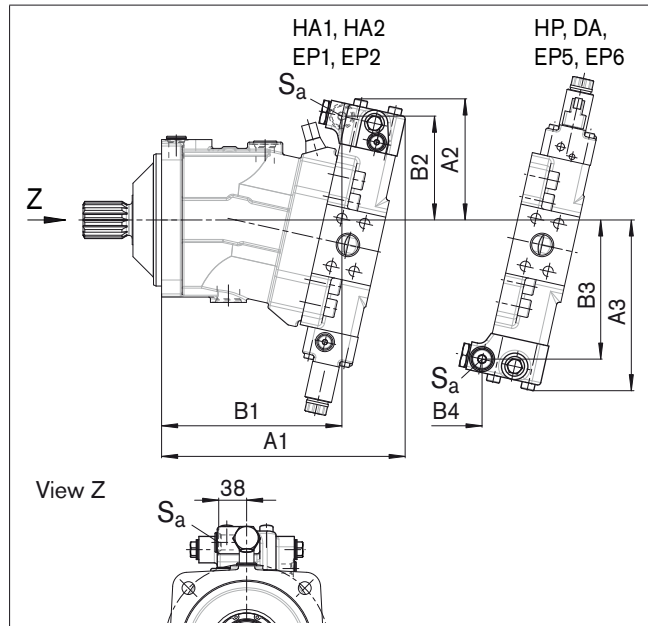

NG	A1	B1	A2	B2	A3	B3	B4
150	325	239	165	142	230	187	166
170	332	246	165	142	233	190	172
215	349	263	172	148	244	201	185

Dimensions size 280

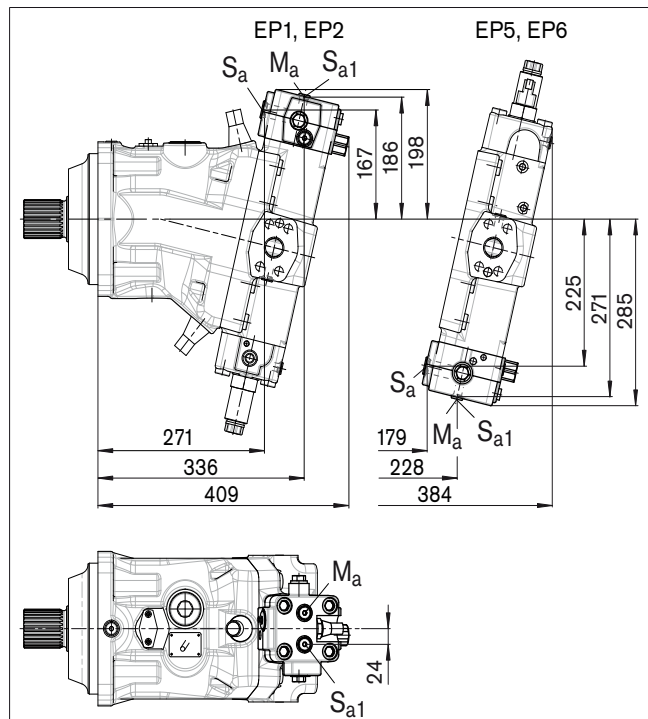

NG	S _a ¹⁾	S _{a1} ¹⁾	M _a ¹⁾
150	22 x 1.5; 15.5 deep	-	-
170	22 x 1.5; 15.5 deep	-	-
215	22 x 1.5; 15.5 deep	-	-
280	22 x 1.5; 15.5 deep	14 x 1.5; 11.5 deep	14 x 1.5; 11.5 deep

1) ISO 6149, ports plugged (in normal operation)

Sensors

Speed sensor

Version A6VM...U ("prepared for speed measuring", i.e. without sensor) has teeth on the rotary group.

With a speed sensor installed, a signal proportional to motor speed can be generated.

The DSM sensor measures the speed and direction of rotation and offers additional diagnostic functions. Ordering code, technical data, dimensions and details on the connector of the DSM sensor can be found in data sheet RE 95132.

The DSM sensor is mounted on the port provided for this purpose with a fixing screw. On delivery without sensor, the port is plugged with a pressure-resistant cover.

We recommend ordering the A6VM variable motor complete with mounted sensor.

Circuit diagram EP

Sizes 60 to 215

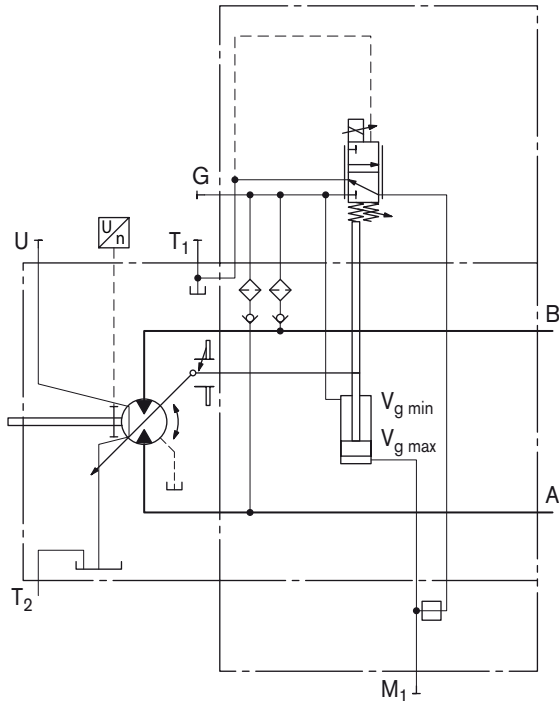

Before finalizing your design, request a binding installation drawing. Dimensions in mm.

Dimensions

Version "U" (sizes 60 to 215): with DSM sensor

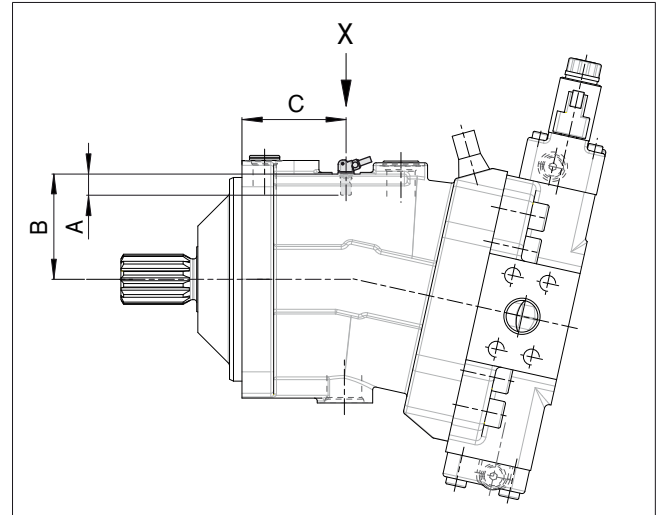

View X

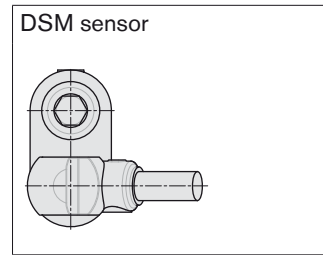

Size		60	85	115	150	170	215
Number of teeth		54	58	67	72	75	80
A	Insertion depth (tolerance - 0.25)	18.4	18.4	18.4	18.4	18.4	18.4
B	Contact surface	75	79	88	93	96	101
C		67	76	78	92	92.5	96

Installation instructions

General

During commissioning and operation, the axial piston unit must be filled with hydraulic fluid and air bled. This is also to be observed following a relatively long standstill as the system may empty via the hydraulic lines.

The case drain fluid in the case interior must be directed to the tank via the highest tank port (T_1 , T_2).

In all operational states, the tank line must flow into the tank below the minimum fluid level.

Installation position

See examples below. Additional installation positions are available upon request.

Recommended installation positions: 1 and 2.

Below-tank installation (standard)

Motor below minimum fluid level of the tank.

Above-tank installation

Motor above minimum fluid level of the tank.

Note on installation position 8 (shaft up):

Even partial draining of the case interior results in insufficient lubrication of the bearings.

A check valve in the tank line (opening pressure 0.5 bar) can prevent draining of the case interior.

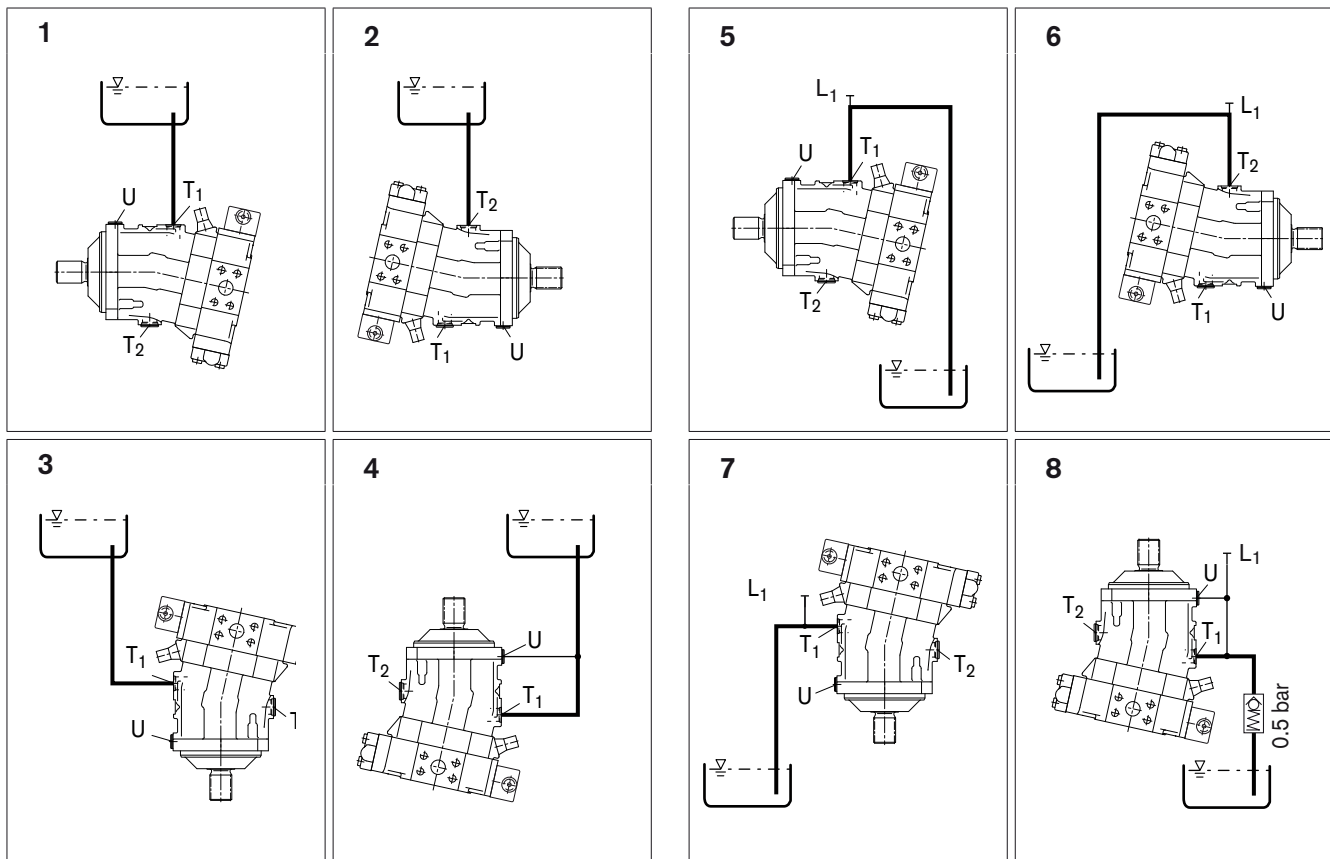

Installation position	Air bleed	Filling
1	–	T_1
2	–	T_2
3	–	T_1
4	U	T_1

Installation position	Air bleed	Filling
5	–	T_1 (L_1)
6	–	T_2 (L_1)
7	–	T_1 (L_1)
8	U	T_1 (L_1)

Notes

Notes

Notes

General instructions

- The A6VM motor is designed to be used in open and closed circuits.
- Project planning, assembly and commissioning of the axial piston unit require the involvement of qualified personnel.
- The service line ports and function ports are only designed to accommodate hydraulic lines.
- During and shortly after operation, there is a risk of burns on the axial piston unit and especially on the solenoids. Take appropriate safety measures (e.g. by wearing protective clothing).
- Depending on the operational state of the axial piston unit (operating pressure, fluid temperature), the characteristic may shift.
- Pressure ports:
The ports and fixing threads are designed for the specified maximum pressure. The machine or system manufacturer must ensure that the connecting elements and lines correspond to the specified operating conditions (pressure, flow, hydraulic fluid, temperature) with the necessary safety factors.
- The data and notes contained herein must be adhered to.
- The following tightening torques apply:
 - Threaded hole for axial piston unit:
The maximum permissible tightening torques $M_{G \max}$ are maximum values for the threaded holes and must not be exceeded. For values, see the following table.
 - Fittings:
Observe the manufacturer's instruction regarding the tightening torques of the used fittings.
 - Fixing screws:
For fixing screws according to DIN 13, we recommend checking the tightening torque individually according to VDI 2230.
 - Locking screws:
For the metal locking screws supplied with the axial piston unit, the required tightening torques of locking screws M_V apply. For values, see the following table.
- The product is not approved as a component for the safety concept of a general machine according to DIN EN ISO 13849.

Threaded port sizes		Maximum permissible tightening torque of the threaded holes $M_{G \max}$	Required tightening torque of the locking screws M_V	WAF hexagon socket of the locking screws
M10 x 1	ISO 6149	30 Nm	20 Nm	5 mm
M12 x 1.5	ISO 6149	50 Nm	35 Nm	6 mm
M14 x 1.5	ISO 6149	80 Nm	45 Nm	6 mm
M16 x 1.5	ISO 6149	100 Nm	55 Nm	8 mm
M18 x 1.5	ISO 6149	140 Nm	70 Nm	8 mm
M22 x 1.5	ISO 6149	210 Nm	100 Nm	10 mm
M27 x 2	ISO 6149	330 Nm	170 Nm	12 mm
M33 x 2	ISO 6149	540 Nm	310 Nm	17 mm ¹⁾
M42 x 2	ISO 6149	720 Nm	330 Nm	22 mm ¹⁾

1) Different from ISO 6149

Bosch Rexroth AG
Hydraulics
Axial Piston Units
Glockeraustraße 2
89275 Elchingen, Germany
Telephone +49 (0) 73 08 82-0
Fax +49 (0) 73 08 72 74
info.brm-ak@boschrexroth.de
www.boschrexroth.com/axial-piston-motors

An den Kelterwiesen 14
72160 Horb, Germany
Telephone +49 (0) 74 51 92-0
Fax +49 (0) 74 51 82 21

© This document, as well as the data, specifications and other information set forth in it, are the exclusive property of Bosch Rexroth AG. It may not be reproduced or given to third parties without its consent.

The data specified above only serve to describe the product. No statements concerning a certain condition or suitability for a certain application can be derived from our information. The information given does not release the user from the obligation of own judgment and verification. It must be remembered that our products are subject to a natural process of wear and aging.

Subject to change.