

Directional control valves, pilot-operated,  
with electrical position feedback and  
integrated electronics (OBE)

Type 4WRLE

**RE 29123**

Edition: 2017-05

Replaces: 2016-06

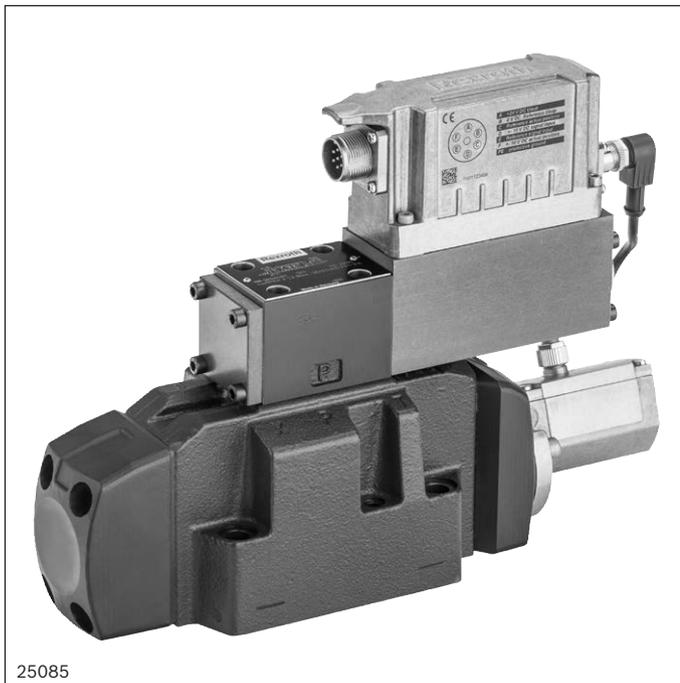

- ▶ Size 10 ... 35
- ▶ Component series 4X
- ▶ Maximum operating pressure 350 bar
- ▶ Rated flow 60 ... 1500 ml/min



## Features

- ▶ Reliable – proven and robust design
- ▶ Safe
  - The control spool of the pilot control valve is in the "fail safe" position when the unit is switched off
  - The control spool of the main valve is in the spring-centered central position and/or in the offset position
- ▶ High quality – control spool and sleeve of the pilot control valve in servo quality
- ▶ Flexible – suitable for position, velocity and pressure control
- ▶ Precise – high response sensitivity and little hysteresis

## Contents

Features	1
Ordering code	2, 3
Symbols	4
Function, section	5, 6
Pilot oil supply	7, 8
Technical data	8 ... 10
Block diagram/controller function block	11
Electrical connections and assignment	12
Characteristic curves	13 ... 30
Dimensions	31 ... 35
Accessories	36
Further information	36

## Ordering code

01	02	03	04	05	06	07	08	09	10	11	12	13	14	15	16
4	WRL	E					J	-	4X	/		/		24	*

01	4 main ports	4
02	Directional control valve, pilot-operated	WRL
03	With integrated electronics	E
04	Size 10	10
	Size 16	16
	Size 25	25
	Size 27	27
	Size 35	35
05	Symbols e. g. E, E1-, W6- etc.; possible version see page 4	

### Rated flow ( $\Delta p = 5$ bar/control edge)

06	<b>- Size 10</b>	
	60 l/min (only symbol E, E1-, W6-, W8-, V, V1-)	60
	100 l/min	100
	<b>- Size 16</b>	
	200 l/min (only symbol W6- and W8-) <sup>1)</sup>	200
	250 l/min (only symbol E, E1-, V, V1- and Q3-)	250
	<b>- Size 25</b>	
	350 l/min (only symbol W6- and W8-) <sup>1)</sup>	350
	400 l/min (only symbol E, E1-, V, V1- and Q3-)	400
	<b>- Size 27</b>	
	430 l/min (only symbol W6- and W8-) <sup>1)</sup>	430
	600 l/min (only symbol E, E1-, V, V1- and Q3-)	600
	<b>- Size 35</b>	
	1000 l/min (only symbol E, E1-, V, V1-)	1000
	1200 l/min (only symbol W6- and W8-) <sup>1)</sup>	1200
1500 l/min (only symbol E, E1-, V, V1- and Q3-)	1500	

### Flow characteristic

07	Linear	L
	Linear with fine control range (available for NG10, other sizes on request)	P
	Progressive with linear fine control (only symbol Q3-)	M
08	Overlap jump (opening point 5% with covered valve; only symbols E, E1-, W6-, W8-)	J
09	Component series 40 ... 49 (40 ... 49: unchanged installation and mounting dimensions)	4X

### Seal material

10	NBR seals	M
	FKM seals	V
	Observe compatibility of seals with hydraulic fluid used	

### Pilot oil flow

11	External pilot oil supply, external pilot oil return	XY
	Internal pilot oil supply, external pilot oil return	PY
	Internal pilot oil supply; internal pilot oil return	PT
	External pilot oil supply, internal pilot oil return	XT

**Ordering code**

01	02	03	04	05	06	07	08	09	10	11	12	13	14	15	16	
<b>4</b>	<b>WRL</b>	<b>E</b>					<b>J</b>	<b>-</b>	<b>4X</b>	<b>/</b>			<b>/</b>		<b>24</b>	<b>*</b>

12	<b>Without</b> damping plate	<b>no code</b>
	<b>With</b> damping plate	<b>D</b>

13	Supply voltage 24 V	<b>24</b>
----	---------------------	-----------

**Interfaces of the control electronics**

14	Command value input $\pm 10$ V	<b>A1</b>
	Command value input 4 ... (12) ... 20 mA	<b>F1</b>

15	<b>Without</b> electronics protection membrane	<b>no code</b>
	<b>With</b> electronics protection membrane	<b>-967</b>

16	Further details in the plain text	<b>*</b>
----	-----------------------------------	----------

<sup>1)</sup> Higher rated flow upon request

### Symbols

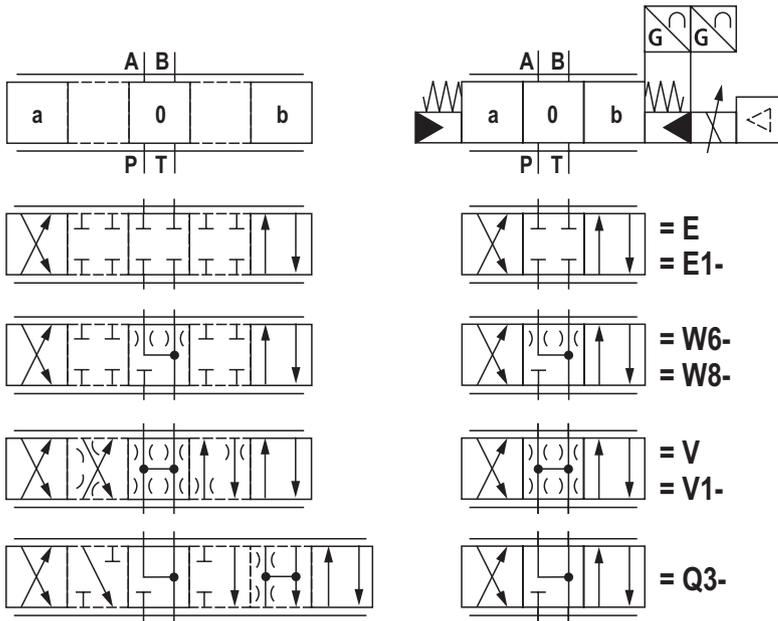

With symbol E1-, V1- and W8-:

$P \rightarrow A: q_{V \max}$      $B \rightarrow T: q_{V/2}$   
 $P \rightarrow B: q_{V/2}$      $A \rightarrow T: q_{V \max}$

Version	simple	detailed
"XY"		
"PY"		
"PT"		
"XT"		

**Notice:**

- ▶ Representation according to DIN ISO 1219-1. Hydraulic interim positions are shown by dashes.
- ▶ For information on the "switch-off behavior", refer to "Technical data" on page 10.

## Function, section: Symbol E. and W.

The valve type 4WRLE is a pilot-operated directional control valve with electrical position feedback and integrated electronics (OBE).

### Set-up

The valve basically consists of 3 main assemblies:

- ▶ Pilot control valve (1) with control spool and sleeve, return spring, control solenoid and inductive position transducer (optional with electronics protection membrane (5) and damping plate (4))
- ▶ Main valve (2) with centering spring and position feedback
- ▶ Integrated control electronics (OBE) (3)

### Function

When the integrated control electronics (OBE) is switched off or inactive, the control spool of the pilot control valve is spring-operated in the "fail-safe" position. The control spool of the main valve is in its spring-centered central position.

The integrated control electronics (OBE) compares the specified command value to the position actual value of the main valve control spool. In case of control deviations, the control solenoid will be activated. Due to the changed magnetic force, the pilot control spool is adjusted against the spring.

The flow which is activated via the control cross-sections leads to an adjustment of the main control spool. The stroke/control cross-section of the main control spool is regulated proportionally to the command value.

The pilot oil supply in the pilot control valve is either internal via port P or external via port X. The feedback can be internal via port T or external via port Y to the tank.

### Control solenoid shut-off

In case of the following errors, the control solenoids are de-energized by the integrated electronics (OBE), the pilot control spool is set to "fail-safe" position and unloads the pilot oil chambers of the main valve. Operated by the spring, the main valve control spool will move to the central position.

- ▶ Falling below the minimum supply voltage
- ▶ Only at interface "F1": falling below the minimum current command value of 2 mA (includes cable break of the command value line (current loop)).

### Damping plate "D"

The damping plate (4) reduces the acceleration amplitudes on the on-board electronics (frequencies >300 Hz).

#### Notice:

Use of the damping plate is not recommended for applications with mainly low-frequency excitation <300 Hz.

### Electronics protection membrane "-967"

To prevent condensate formation in the housing of the integrated electronics (OBE), an electronics protection membrane (5) can be used.

Recommended for use outside industry-standard conditions with high ambient air humidity and significant cyclic temperature changes (e.g. outdoors).

#### Notice:

Pilot-operated 4/3-directional control valves with positive overlap are functional in controlled or regulated axes. The overlap in the de-energized state is approx. 20% of the control spool stroke. While the electrical supply voltage is switched off, the drive may be accelerated for a short time in functional direction P to B.

For sectional drawing see page 6.



**Pilot oil supply** (schematic illustration)

**NG10**

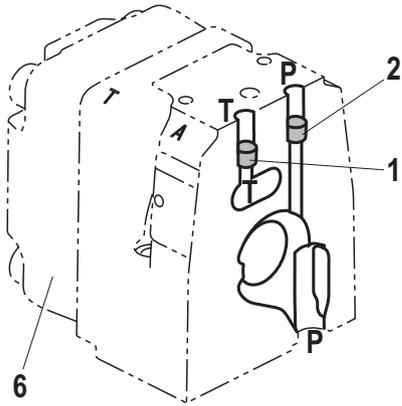

**NG16**

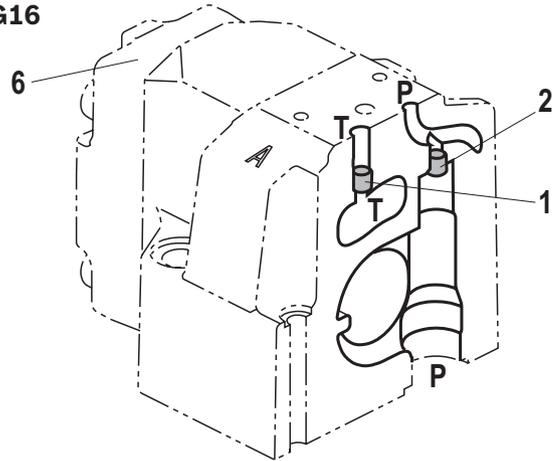

**NG25**

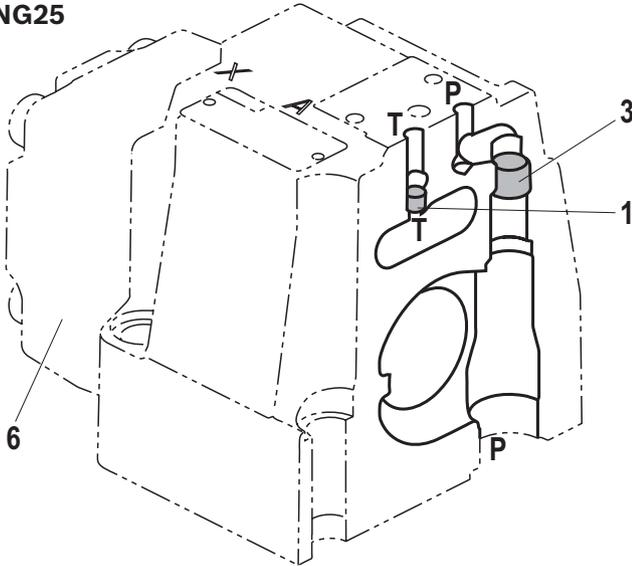

**NG27**

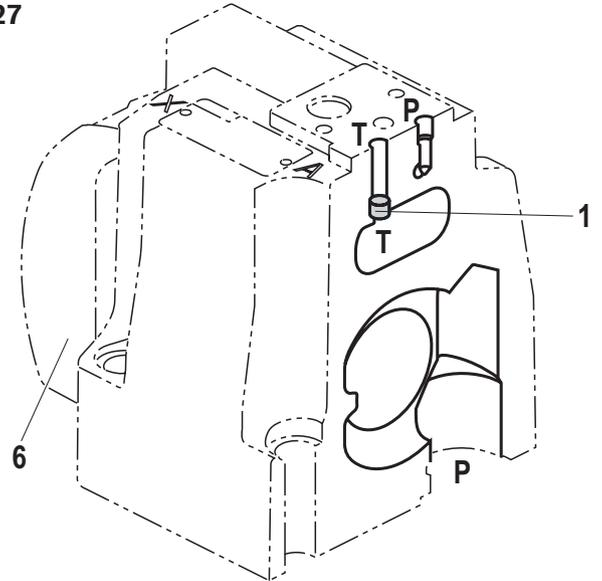

**NG35**

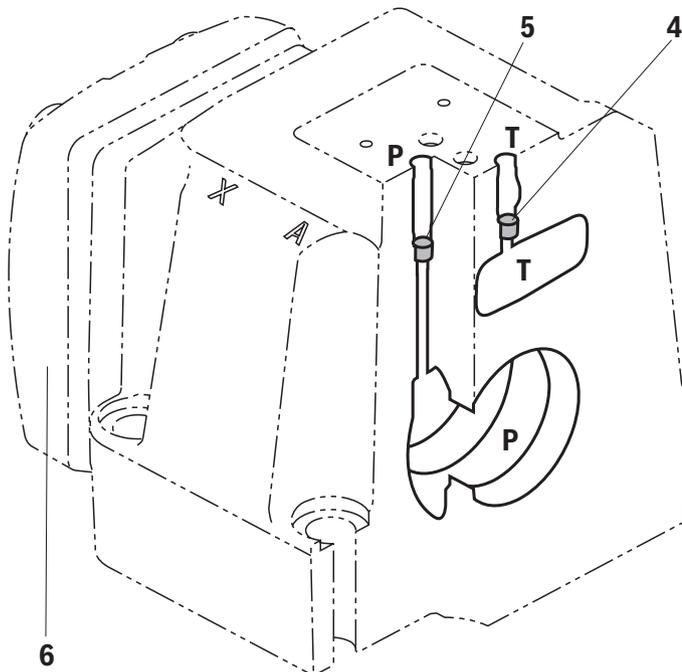

- 1 Plug screw M6 according to DIN 906, wrench size 3 – pilot oil return
- 2 Plug screw M6 according to DIN 906, wrench size 3 – pilot oil supply
- 3 Plug screw M12 x 1.5 according DIN 906, wrench size 6 – pilot oil supply
- 4 Plug screw 1/16-27 NPTF, wrench size 4 – pilot oil return
- 5 Plug screw 1/16-27 NPTF, wrench size 4 – pilot oil supply
- 6 Housing cover main stage (position transducer side)

**Pilot oil supply**

external: **2, 3, 5** closed  
 internal: **2, 3, 5** open

**Pilot oil return**

external: **1, 4** closed  
 internal: **1, 4** open

**Further explanations on page 8.**

## Pilot oil supply

### Version "XY"

#### External pilot oil supply

#### External pilot oil return

In this version, the pilot oil is supplied from a separate control circuit (external).

The pilot oil return is not directed into channel T of the main valve, but is separately directed to the tank via port Y (external).

### Version "PY"

#### Internal pilot oil supply

#### External pilot oil return

With this version, the pilot oil is supplied from channel P of the main valve (internal).

The pilot oil return is not directed into channel T of the main valve, but is separately directed to the tank via port Y (external).

In the subplate, port X is to be closed.

### Version "PT"

#### Internal pilot oil supply

#### Internal pilot oil return

With this version, the pilot oil is supplied from channel P of the main valve (internal).

The pilot oil is directly returned to channel T of the main valve (internal).

In the subplate, ports X and Y are to be closed.

### Version "XT"

#### External pilot oil supply

#### Internal pilot oil return

In this version, the pilot oil is supplied from a separate control circuit (external).

The pilot oil is directly returned to channel T of the main valve (internal).

In the subplate, port Y is to be closed.

## Technical data

(For applications outside these parameters, please consult us!)

general		NG	10	16	25	27	35
Size		NG	10	16	25	27	35
Installation position			Any				
Ambient temperature range		°C	-20 ... +60				
Maximum storage time		Years	1 (if the storage conditions are observed; refer to the operating instructions 07600-B)				
Sine test according to DIN EN 60068-2-6	▶ Without damping plate		10 ... 2000 Hz / maximum of 10 g / 10 cycles / 3 axes				
	▶ With damping plate <sup>1)</sup>		10 ... 2000 Hz / maximum of 10 g / 10 cycles / 3 axes				
Noise test according to DIN EN 60068-2-64	▶ Without damping plate		20 ... 2000 Hz / 10 g <sub>RMS</sub> / 30 g peak / 30 min. / 3 axes				
	▶ With damping plate <sup>1)</sup>		20 ... 2000 Hz / 10 g <sub>RMS</sub> / 30 g peak / 24 h / 3 axes				
Transport shock according to DIN EN 60068-2-27	▶ Without damping plate		15 g / 11 ms / 3 shocks / 3 axes				
	▶ With damping plate <sup>1)</sup>		15 g / 11 ms / 3 shocks / 3 axes				
Shock according to DIN EN 60068-2-27	▶ With damping plate <sup>1)</sup>		35 g / 6 ms / 1000 shocks / 3 axes				
Weight		kg	9	12	19	21	80
Maximum relative humidity (no condensation)		%	95				
Maximum solenoid surface temperature		°C	120 (individual operation)				
MTTF <sub>d</sub> value according to EN ISO 13849		Years	75 (for further details see data sheet 08012)				

<sup>1)</sup> Not recommended for applications with mainly low-frequency excitation < 300 Hz

**Technical data**

(For applications outside these parameters, please consult us!)

hydraulic												
Size	NG	10	16	25	27	35						
Maximum operating pressure	▶ Port A, B, P											
	– External pilot oil supply	bar	350			270	350					
	– Pilot oil supply internal	bar	280			270	280					
	▶ Port X	bar	280			270	280					
	▶ Ports T, Y	bar	250			210	250					
Minimum pilot pressure (pilot control valve)	bar	10										
Maximum flow	l/min	300	800	1250	1850	4700						
Rated flow ( $\Delta p = 5$ bar/control edge) <sup>2)</sup>	l/min	60/100	200/250	350/400	430/600	1000/1200/1500						
Pilot oil flow <sup>3)</sup>	▶ Symbol E, W	l/min	2.4	3.5	7.5	23						
	▶ Symbol V, Q3-	l/min	4.5	11.5	22	29						
Maximum leakage flow (inlet pressure 100 bar)	▶ Symbol E, E1-											
	– Main valve	l/min	0.06	0.13	0.17	0.61						
	– Main valve + pilot control valve	l/min	0.14	0.28	0.42	1.01						
	▶ Symbol W6-, W8-											
	– Main valve	l/min	0.12	0.26	0.35	1.23						
	– Main valve + pilot control valve	l/min	0.2	0.41	0.6	1.63						
Maximum zero flow (inlet pressure 100 bar)	▶ Symbol V, V1-											
	– Main valve	l/min	1.7	2.3	2.8	3.3	7.2					
	– Main valve + pilot control valve	l/min	1.85	2.6	3.2	3.7	7.65					
	▶ Symbol Q3-											
	– Main valve	l/min	0.4	1.6	1.8	2.2	1.6					
	– Main valve + pilot control valve	l/min	0.55	1.9	2.2	2.6	2.05					
Flow unloading central position $\Delta p = 5$ bar/control edge			A→T	B→T	A→T	B→T	A→T	B→T	A→T	B→T	A→T	B→T
	▶ Symbol W6-	l/min	2.8	2.8	4	4	6	6	6	6	25	25
	▶ Symbol W8-	l/min	2.8	1.4	4	2	6	3	6	3	25	12.5
Pilot oil volume	0 ... 100%	cm <sup>3</sup>	1.3	2.9	6.8	6.8	33.2					
Hydraulic fluid			See table below									
Viscosity range	▶ recommended	mm <sup>2</sup> /s	30 ... 45									
	▶ maximum admissible	mm <sup>2</sup> /s	20 ... 380									
Hydraulic fluid temperature range (flown-through)		°C	–20 ... +70									
Maximum admissible degree of contamination of the hydraulic fluid cleanliness class according to ISO 4406 (c)			Class 18/16/13 <sup>4)</sup>									

Hydraulic fluid	Classification	Suitable sealing materials	Standards	Data sheet
Mineral oils	HL, HLP, HLPD, HVLP, HVLDP	NBR, FKM	DIN 51524	90220
Bio-degradable	▶ Insoluble in water	HETG	ISO 15380	90221
		HEES		
	▶ Soluble in water	HEPG	ISO 15380	
Flame-resistant	▶ Water-free	HFDU, HFDR	ISO 12922	90222
	▶ Containing water	HFC (Fuchs Hydrotherm 46M, Petrofer Ultra Safe 620)	ISO 12922	90223

**Important information on hydraulic fluids:**

- ▶ For further information and data on the use of other hydraulic fluids, please refer to the data sheets above or contact us!
- ▶ There may be limitations regarding the technical valve data (temperature, pressure range, life cycle, maintenance intervals, etc.)!
- ▶ The ignition temperature of the hydraulic fluid used must be 40 K higher than the maximum solenoid surface temperature.

**▶ Flame-resistant – containing water:**

- Maximum operating pressure 210 bar
- Maximum pressure differential per control edge 175 bar
- Pressure pre-loading at the tank port >20% of the pressure differential, otherwise increased cavitation erosion
- Life cycle as compared to operation with mineral oil HL, HLP 50 ... 100%
- Maximum hydraulic fluid temperature 50 °C

Explanation of the footnotes see page 10.

**Technical data**

(For applications outside these parameters, please consult us!)

- 2) Flow for deviating
- $\Delta p$
- (control edge):

$$q_x = q_{Vnom} \times \sqrt{\frac{\Delta p_x}{5}}$$

- 3) At port X and Y with stepped input signal from 0 ... 100% (pilot pressure 100 bar)

- 4) The cleanliness classes specified for the components must be adhered to in hydraulic systems. Effective filtration prevents faults and simultaneously increases the life cycle of the components.

Available filters can be found at [www.boschrexroth.com/filter](http://www.boschrexroth.com/filter).

static / dynamic						
Size	NG	10	16	25	27	35
Hysteresis	%	< 0.1				
Response sensitivity	%	< 0.05				
Range of inversion	%	< 0.08				
Manufacturing tolerance $q_{Vmax}$	%	≤ 10				
Actuating time for 0 ... 100% at X = 100 bar	ms	40	85	80	80	100
Switch-off behavior (after electrical shut-off)	▶ Symbol E, E1-, W6-, W8-	Pilot control valve in fail-safe position, main valve moves to overlapped spring-centered central position				
	▶ Symbol V, V1-	Pilot control valve in fail-safe position, main valve moves to spring-centered "offset position" (approx. 6%, P→B/A→T)				
	▶ Symbol Q3	Pilot control valve in fail-safe position, main valve moves to spring-centered "offset position" (P blocked, A/B to port T open)				
Temperature drift (temperature range 20 °C ... 80 °C)	%/10 °C	Zero shift < 0.25				
Zero compensation		Set in the plant to ±1%				

electrical, integrated electronics (OBE)	
Relative duty cycle	% 100 (continuous operation)
Protection class according to EN 60529	IP 65 with mounted and locked plug-in connectors
Supply voltage	VDC 24
▶ Terminal A	VDC min. 19 / max. 36
▶ Terminal B	VDC 0
Maximum admissible residual ripple	Vpp 2.5
Maximum power consumption	VA 40
Fuse protection, external	A <sub>T</sub> 2.5 (time-lag)
Input, version "A1"	Differential amplifier, $R_i = 100 \text{ k}\Omega$
▶ Terminal D ( $U_E$ )	VDC 0 ... ±10
▶ Terminal E	VDC 0
Input, version "F1"	Load, $R_{sh} = 200 \Omega$
▶ Terminal D ( $I_{D-E}$ )	mA 4 ... 20
▶ Terminal E ( $I_{D-E}$ )	Current loop $I_{D-E}$ feedback
Maximum voltage of the differential inputs against 0 V	D → B; E → B (max. 18 V)
Test signal, version "A1"	LVDT
▶ Terminal F ( $U_{Test}$ )	V 0 ... ±10
▶ Terminal C	Reference 0 V
Test signal, version "F1"	LVDT signal 4 ... 20 mA on external load 200 ... 500 $\Omega$ maximum
▶ Terminal F ( $I_{F-C}$ )	mA 4 ... 20
▶ Terminal C ( $I_{F-C}$ )	Current loop $I_{F-C}$ feedback
Functional ground and screening	See page 12 (EMC-compliant installation)
Adjustment	Calibrated in the plant, see valve characteristic curves page 13 ... 30
Conformity	CE according to EMC Directive 2014/30/EU tested according to EN 61000-6-2 and EN 61000-6-3

Block diagram/controller function block

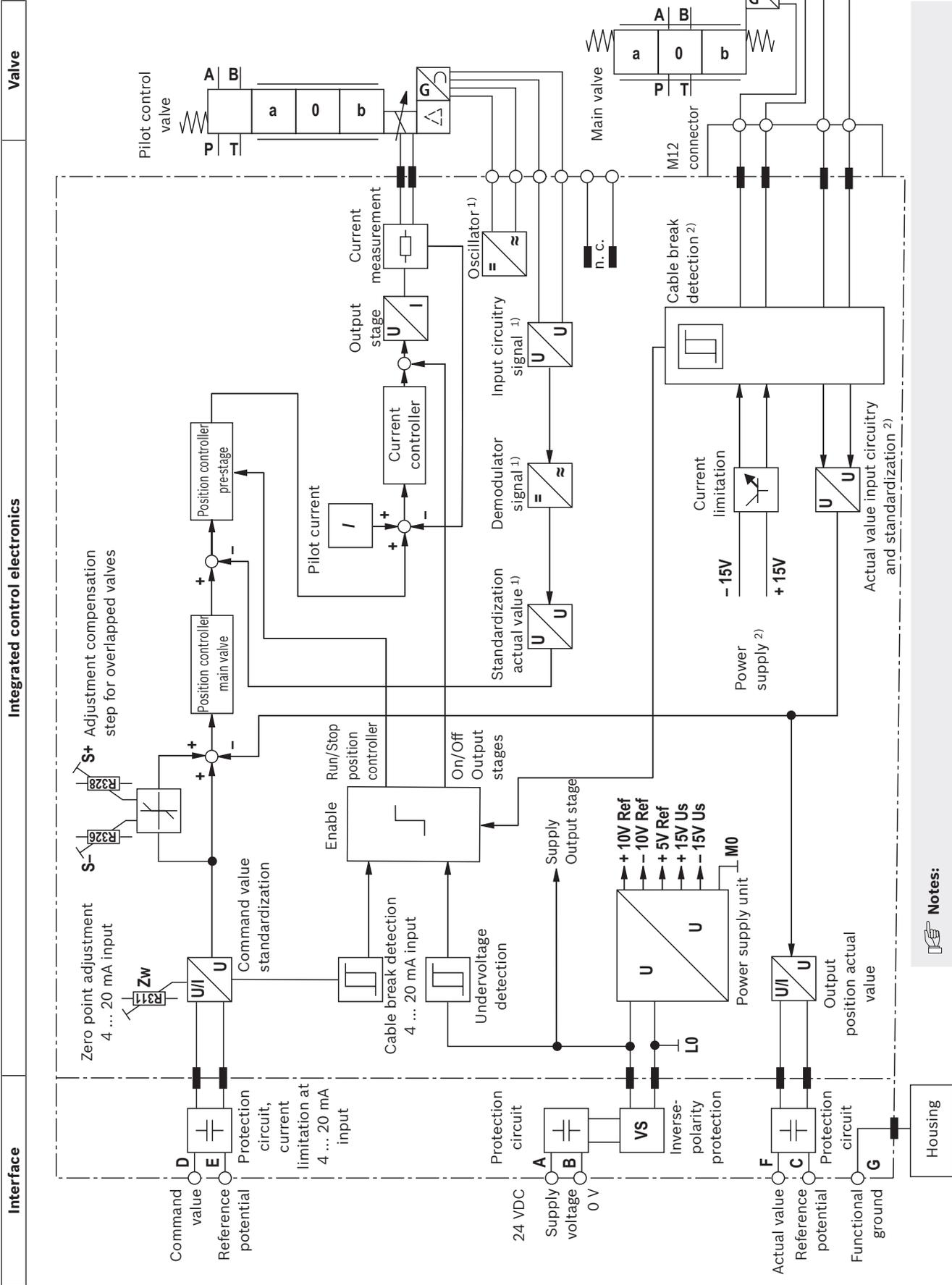

**Notes:**

- ▶ Electrical signals provided via control electronics (e. g. actual value) must not be used for switching off safety-relevant machine functions.
- ▶ The factory setting of the potentiometer must not be changed.

1) Position transducer pilot control valve  
 2) Position transducer main valve

## Electrical connections and assignment

### Connector pin assignment

Pin	Signal	Assignment interface A1	Assignment interface F1
A	Supply voltage	24 VDC	
B		0 V	
C	Reference potential actual value	Reference potential actual value - pin F	
D	Differential amplifier input	Command value $\pm 10$ V	Command value 4 ... 20 mA
E		Reference potential command value - pin D	
F	Measuring output (actual value)	Actual value $\pm 10$ V	Actual value 4 ... 20 mA
PE		Functional ground (directly connected to the valve housing)	

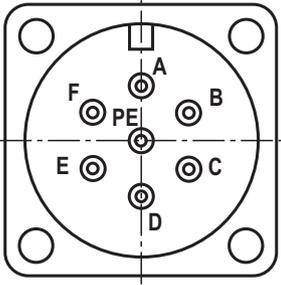

<b>Command value:</b>	<ul style="list-style-type: none"> <li>▶ Positive command value (0 ... 10 V or 12 ... 20 mA on D and reference potential on E cause flow from P → A and B → T.</li> <li>▶ Negative command value (0 ... -10 V or 12 ... 4 mA) at D and reference potential at E cause flow from P → B and A → T.</li> </ul>
<b>Connection cable (recommendation):</b>	<ul style="list-style-type: none"> <li>▶ Up to 20 m cable length type LiYCY 7 x 0.75 mm<sup>2</sup></li> <li>▶ Up to 40 m cable length type LiYCY 7 x 1.0 mm<sup>2</sup></li> <li>▶ EMC-compliant installation:               <ul style="list-style-type: none"> <li>- Apply screening to both line ends</li> <li>- Use metal mating connector (see page 36)</li> </ul> </li> <li>▶ Alternatively up to 30 m cable length admissible               <ul style="list-style-type: none"> <li>- Apply screening on supply side</li> <li>- Plastic mating connector (see page 36) can be used</li> </ul> </li> </ul>

**Notice:**

Mating connectors, separate order, see page 36 and data sheet 08006.

**Characteristic curves:** Flow characteristic "L"  
 (valid for HLP46,  $\vartheta_{oil} = 40 \pm 5 \text{ }^\circ\text{C}$ ;  $\Delta p = 5 \text{ bar/control edge}$ )

**Flow/signal function**

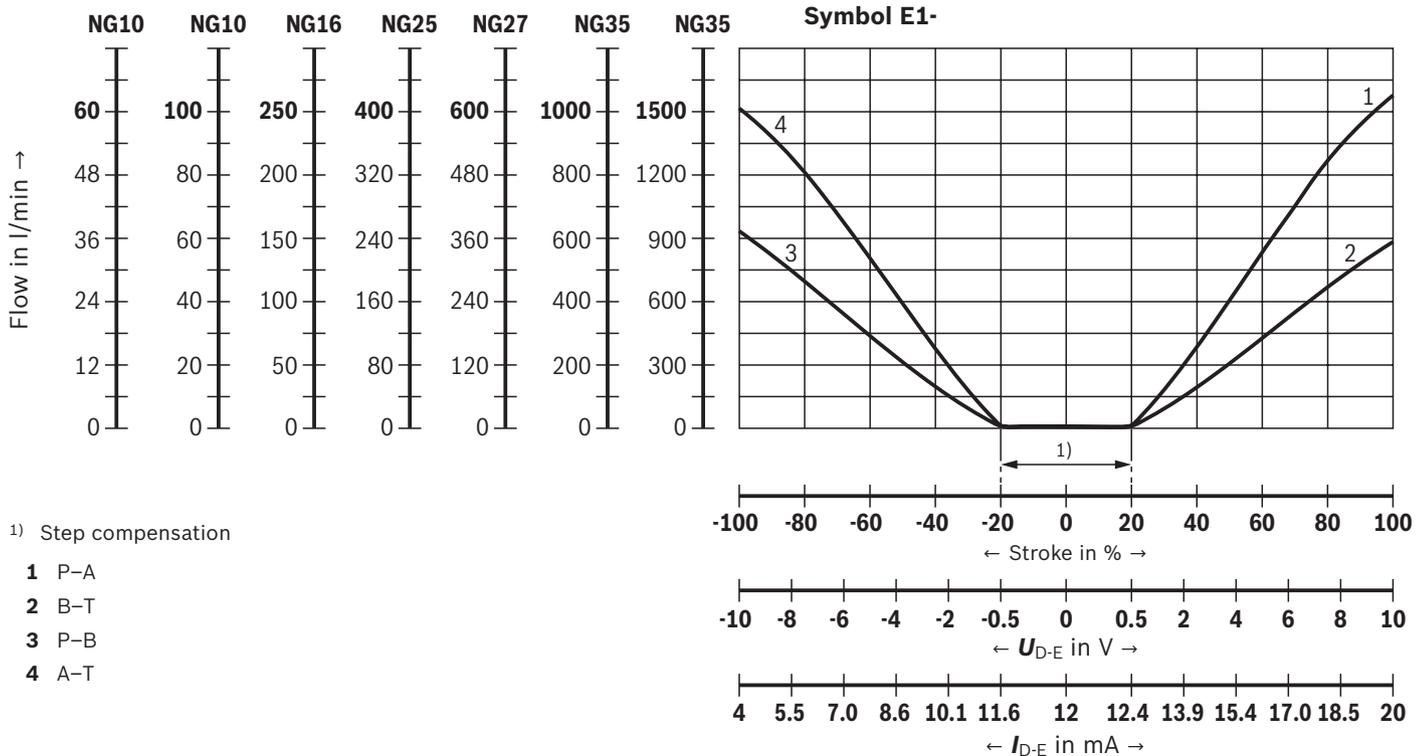
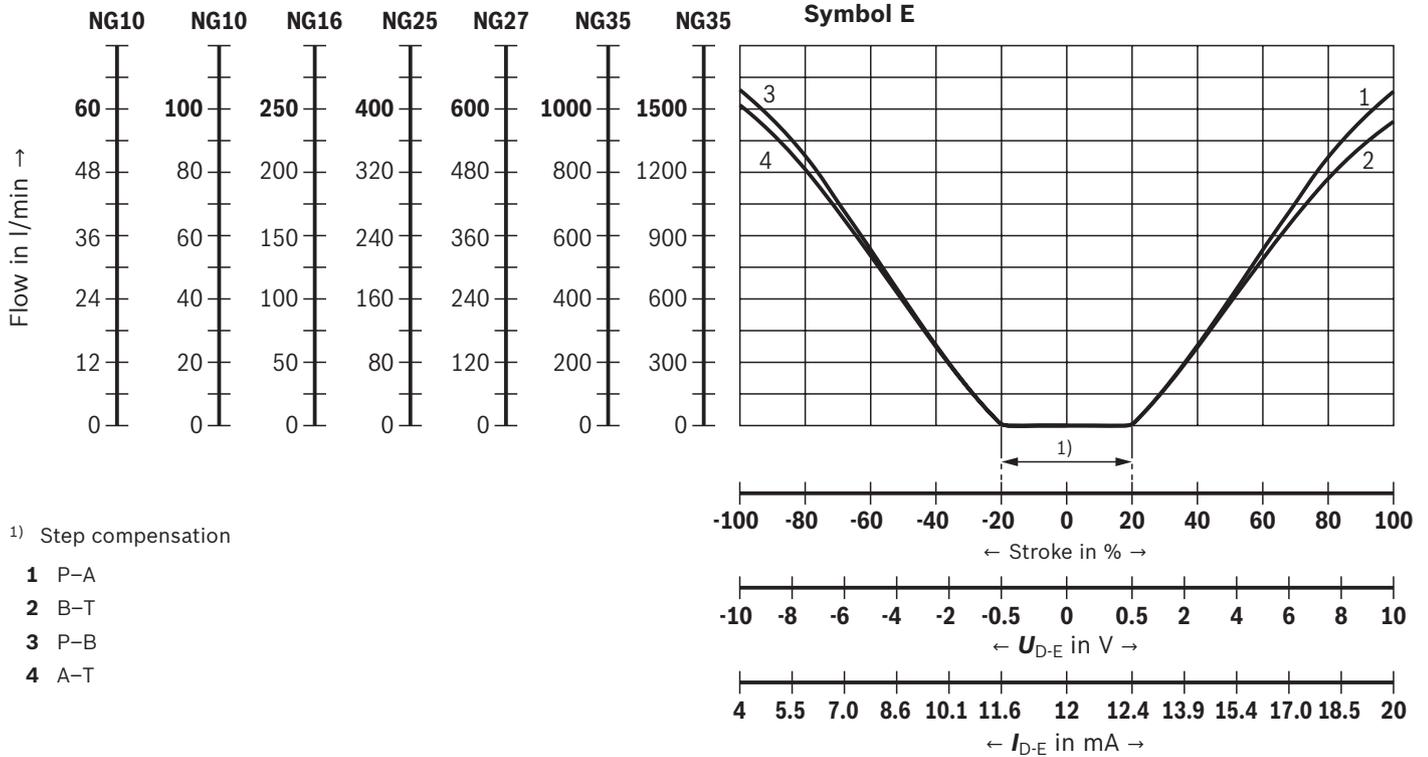

**Characteristic curves:** Flow characteristic "L"  
 (valid for HLP46,  $\vartheta_{oil} = 40 \pm 5 \text{ }^\circ\text{C}$ ;  $\Delta p = 5 \text{ bar/control edge}$ )

**Flow/signal function**

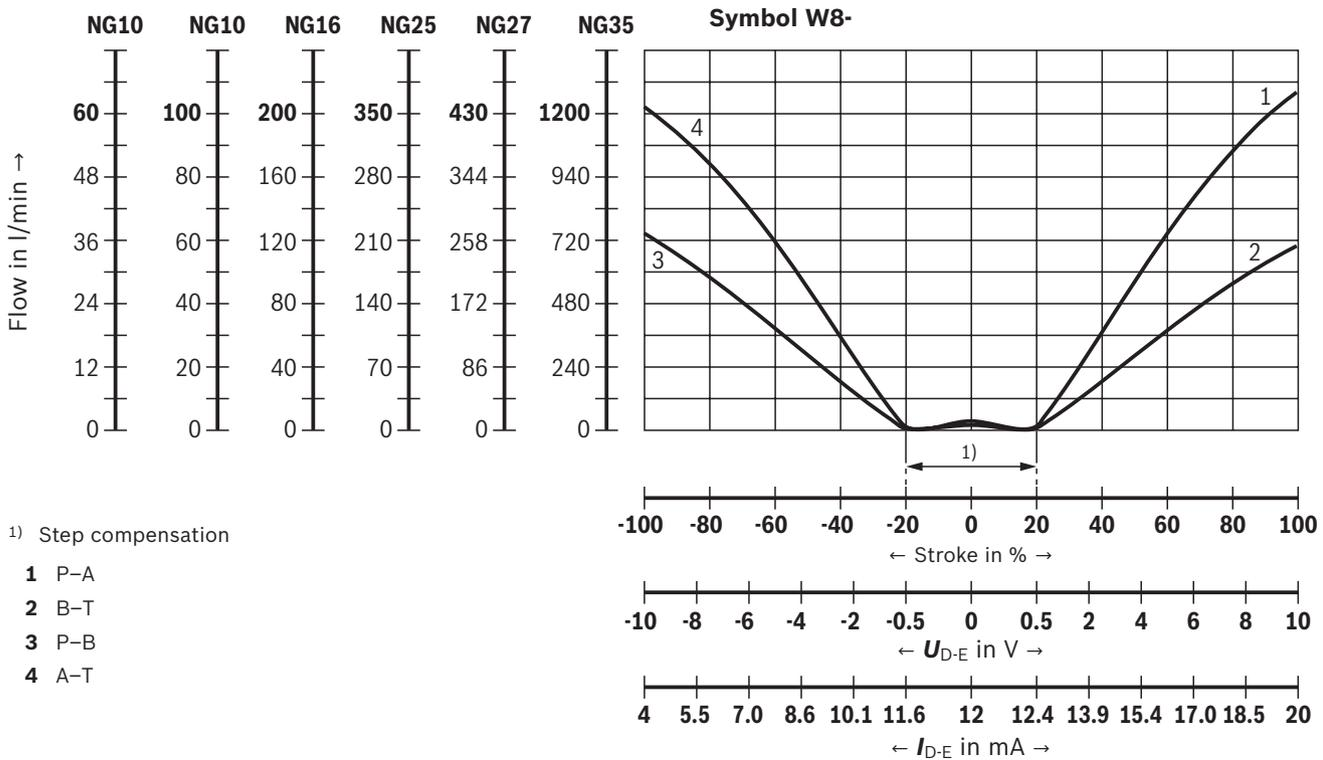
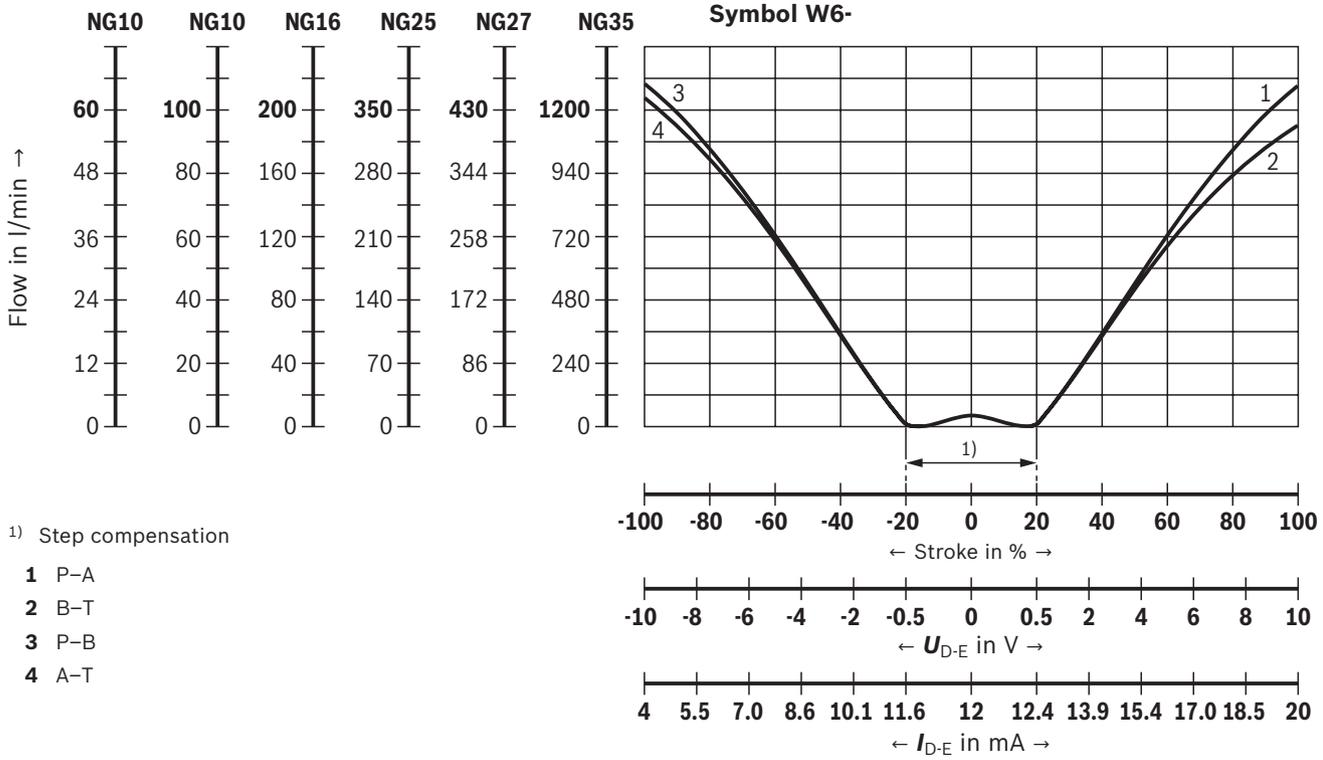

**Characteristic curves:** Flow characteristic "L"  
 (valid for HLP46,  $\vartheta_{oil} = 40 \pm 5 \text{ }^\circ\text{C}$ ;  $\Delta p = 5 \text{ bar/control edge}$ )

**Flow/signal function**

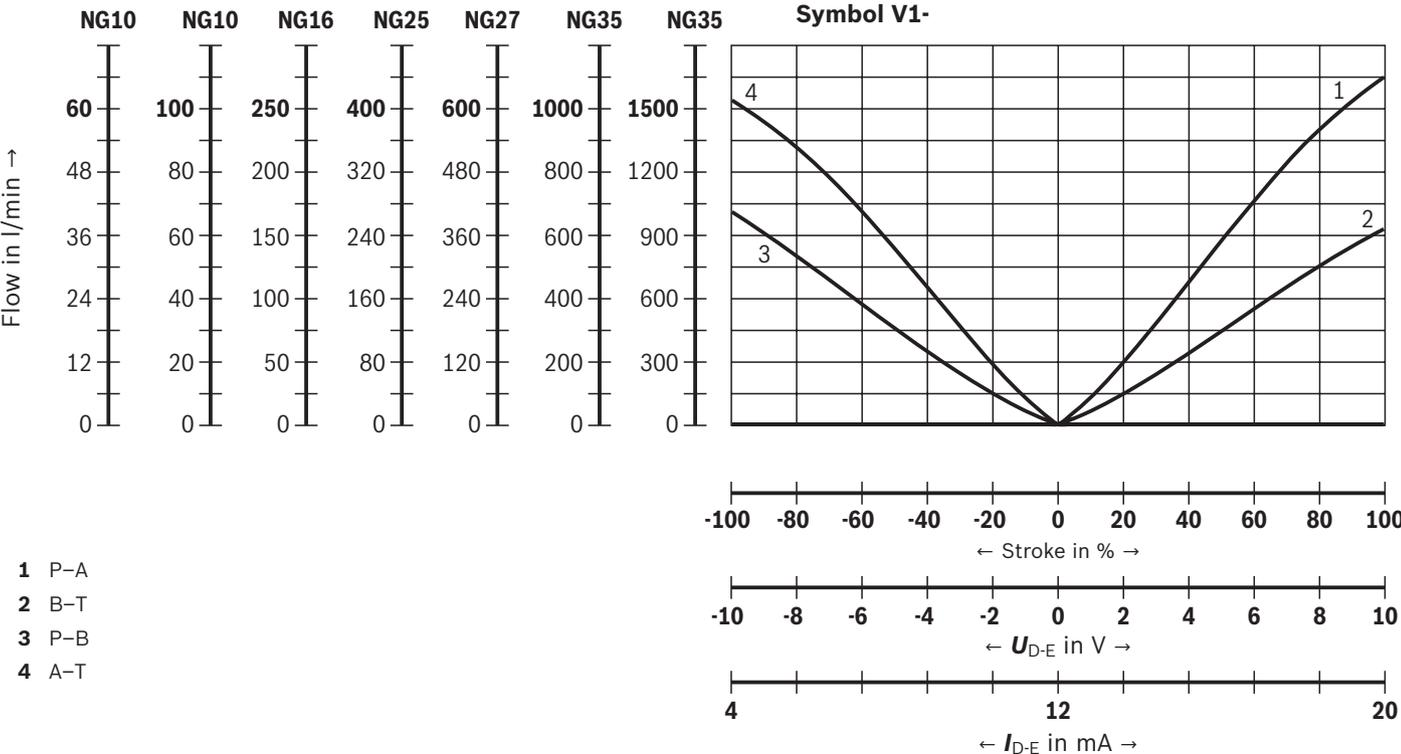
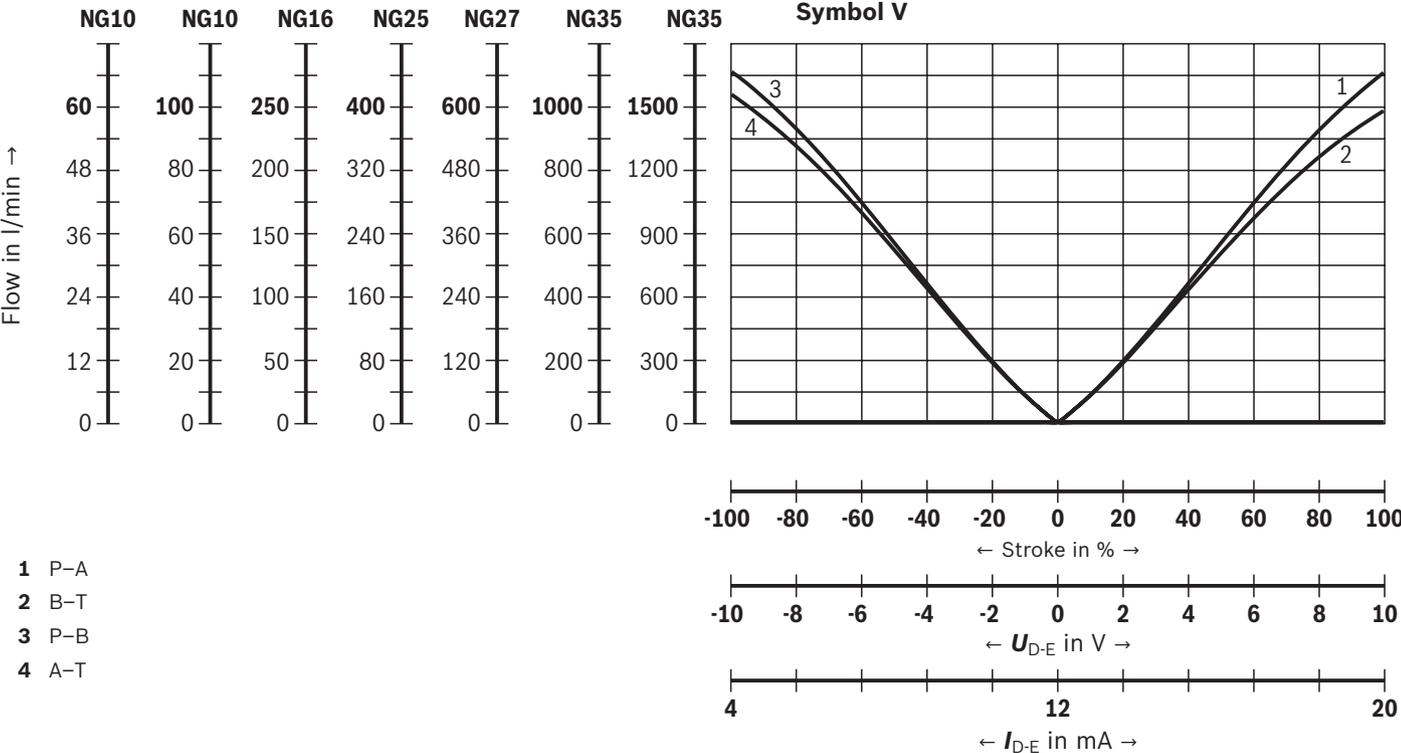

**Characteristic curves:** Flow characteristic "P"  
 (valid for HLP46,  $\vartheta_{oil} = 40 \pm 5 \text{ }^\circ\text{C}$ ;  $\Delta p = 5 \text{ bar/control edge}$ )

**Flow/signal function**

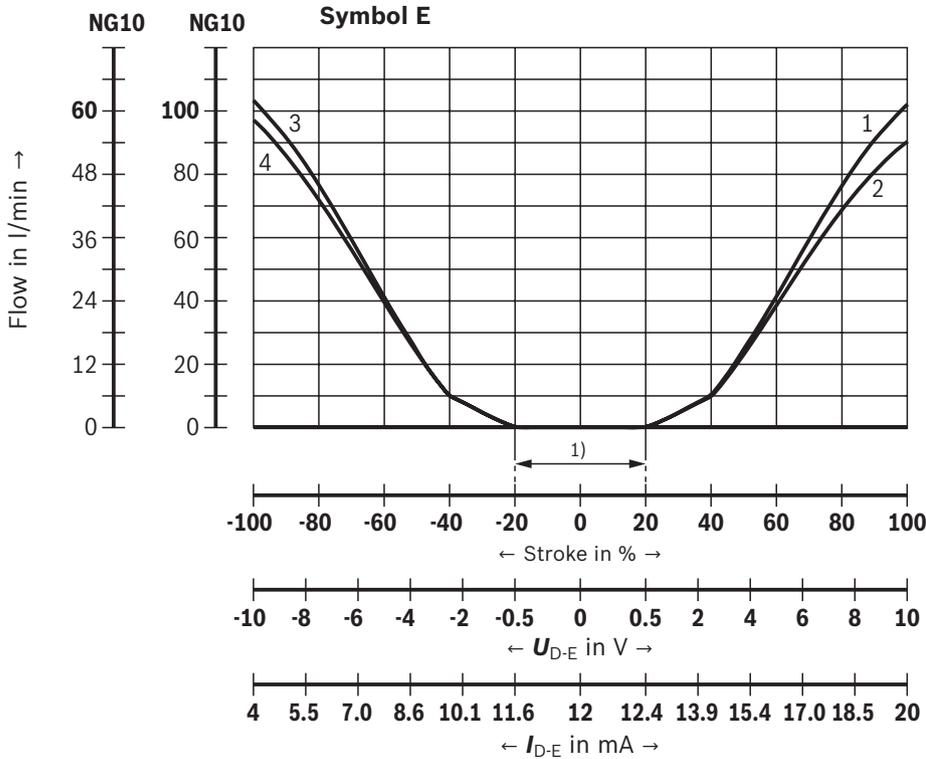

1) Step compensation

- 1 P-A
- 2 B-T
- 3 P-B
- 4 A-T

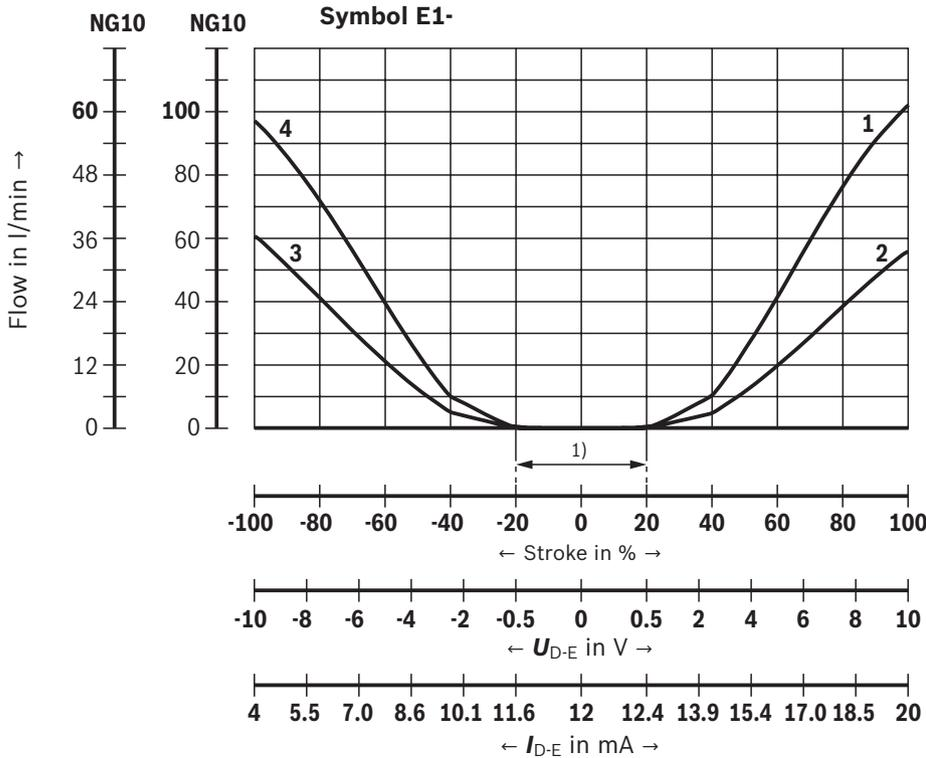

1) Step compensation

- 1 P-A
- 2 B-T
- 3 P-B
- 4 A-T

**Characteristic curves:** Flow characteristic "P"  
 (valid for HLP46,  $\vartheta_{oil} = 40 \pm 5 \text{ }^\circ\text{C}$ ;  $\Delta p = 5 \text{ bar/control edge}$ )

**Flow/signal function**

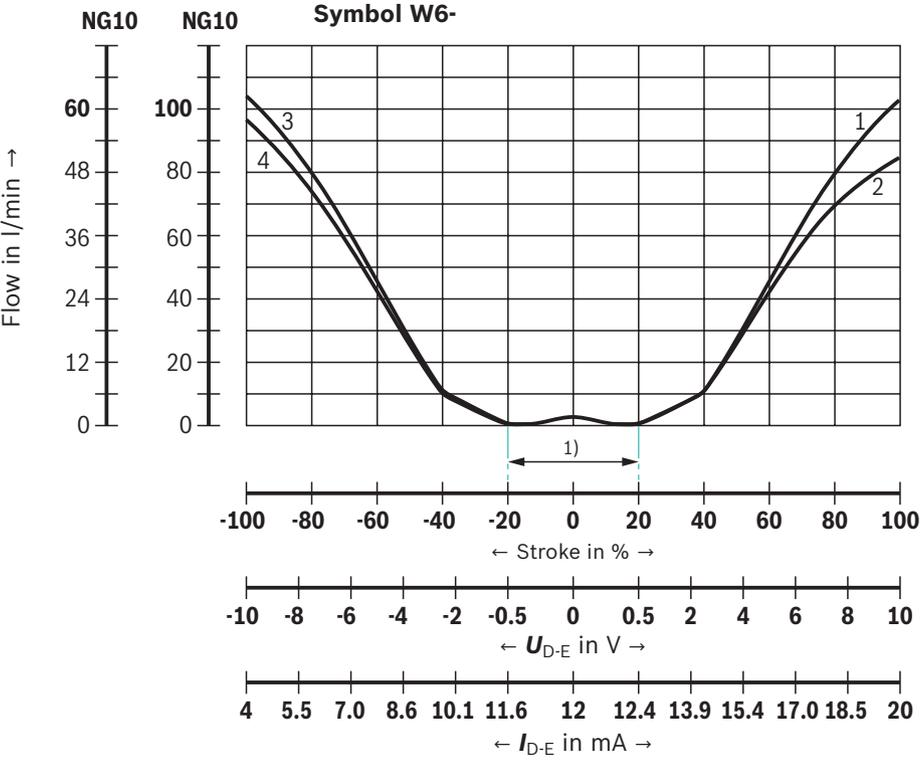

- 1) Step compensation
- 1 P-A
- 2 B-T
- 3 P-B
- 4 A-T

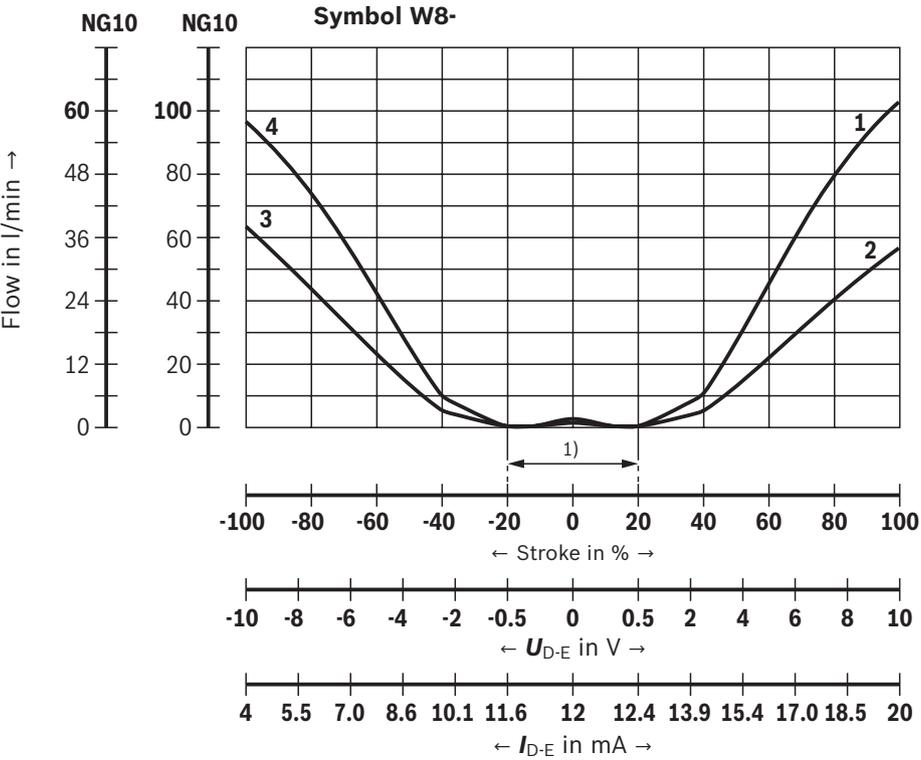

- 1) Step compensation
- 1 P-A
- 2 B-T
- 3 P-B
- 4 A-T

**Characteristic curves:** Flow characteristic "P"  
 (valid for HLP46,  $\vartheta_{oil} = 40 \pm 5 \text{ }^\circ\text{C}$ ;  $\Delta p = 5 \text{ bar/control edge}$ )

**Flow/signal function**

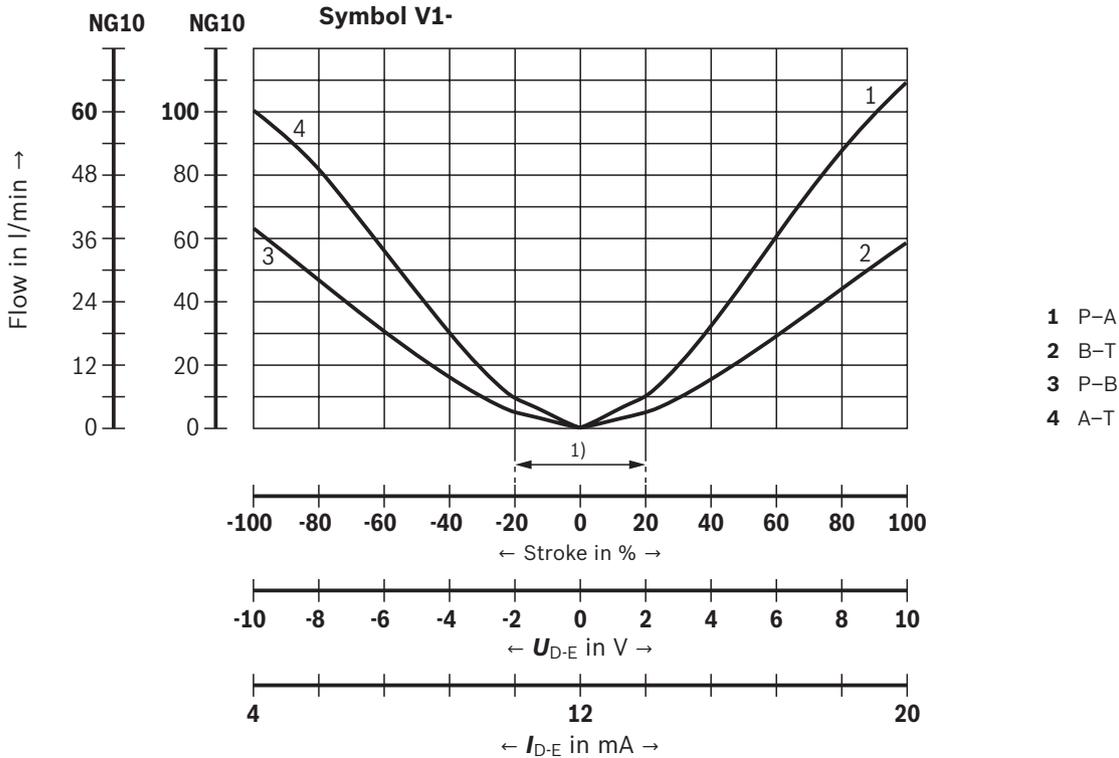
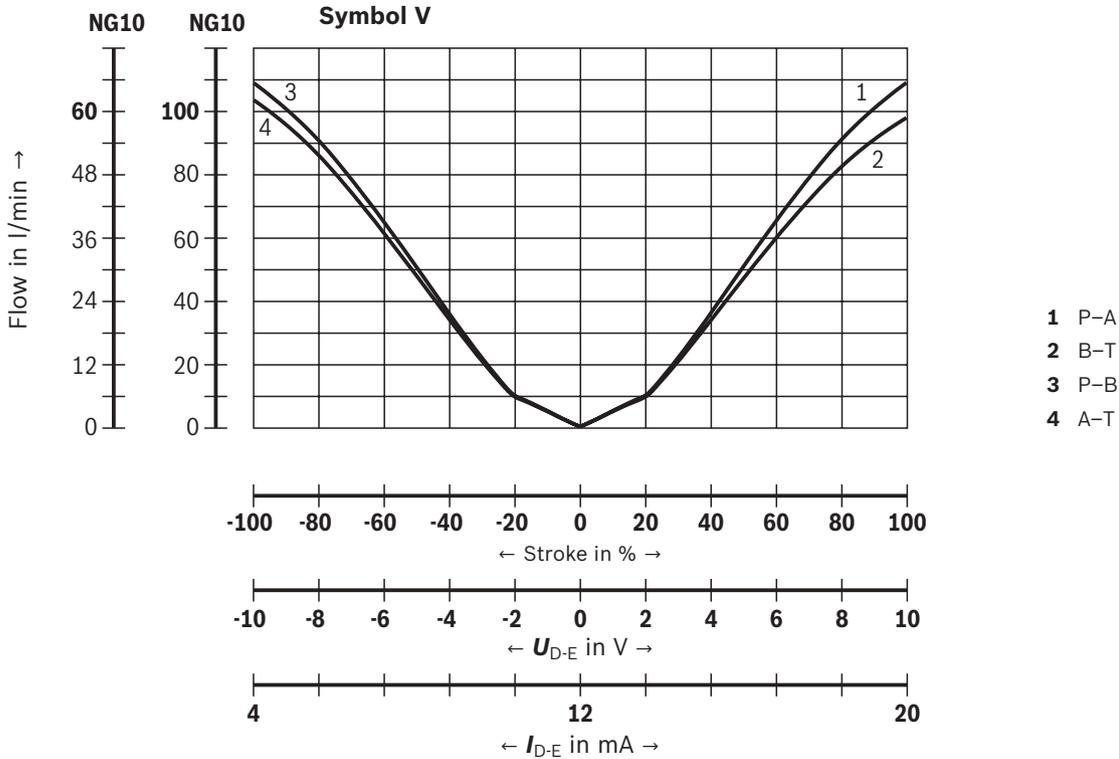

**Characteristic curves:** Flow characteristic "M"  
 (valid for HLP46,  $\vartheta_{oil} = 40 \pm 5 \text{ }^\circ\text{C}$ ;  $\Delta p = 5 \text{ bar/control edge}$ )

**Flow/signal function**

**Symbol Q3, version "100"**

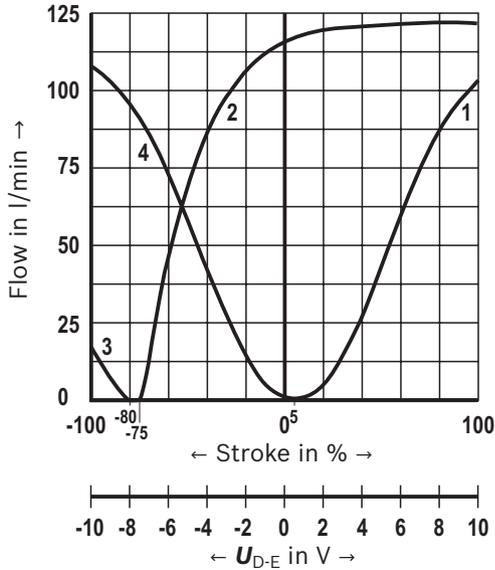

**Symbol Q3, version "250"**

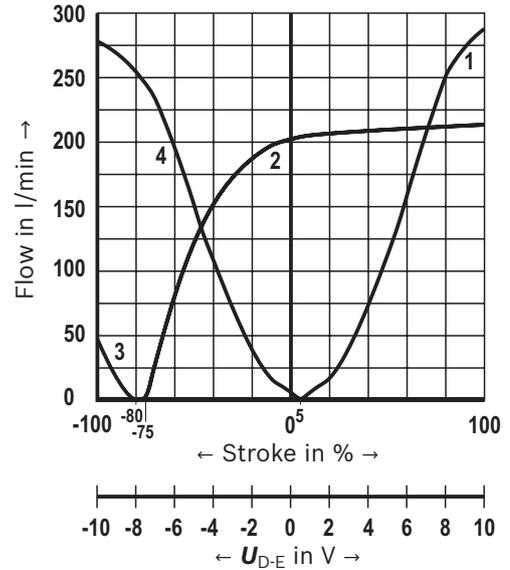

**Symbol Q3, version "400"**

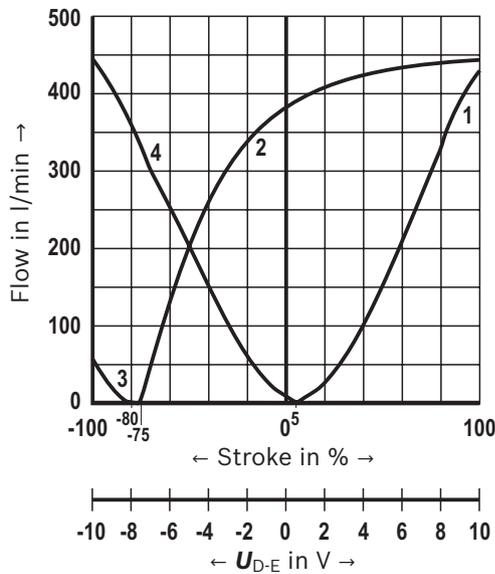

**Symbol Q3, version "600"**

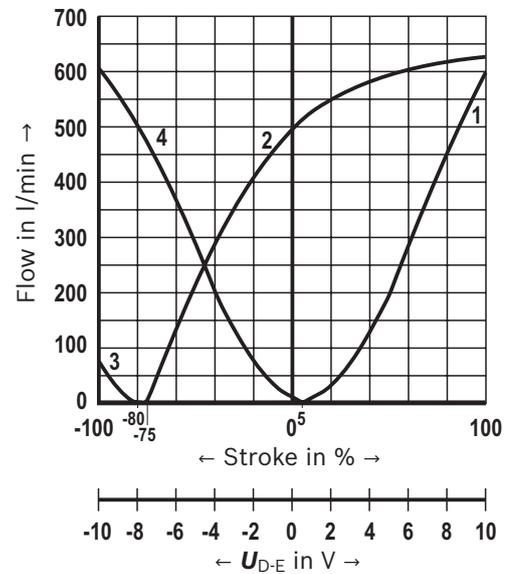

- 1 P-A
- 2 B-T
- 3 P-B
- 4 A-T

**Characteristic curves:** Flow characteristic "M"  
 (valid for HLP46,  $\vartheta_{oil} = 40 \pm 5 \text{ }^\circ\text{C}$ ;  $\Delta p = 5 \text{ bar/control edge}$ )

**Flow/signal function**

Symbol Q3, version "1500"

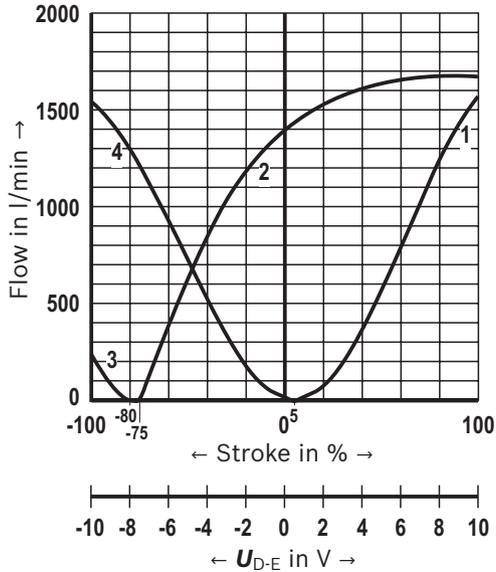

- 1 P-A
- 2 B-T
- 3 P-B
- 4 A-T

**Characteristic curves**  
 (measured with HLP46,  $\vartheta_{oil} = 40 \pm 5 \text{ }^\circ\text{C}$ )

**Pressure/signal characteristic curve**

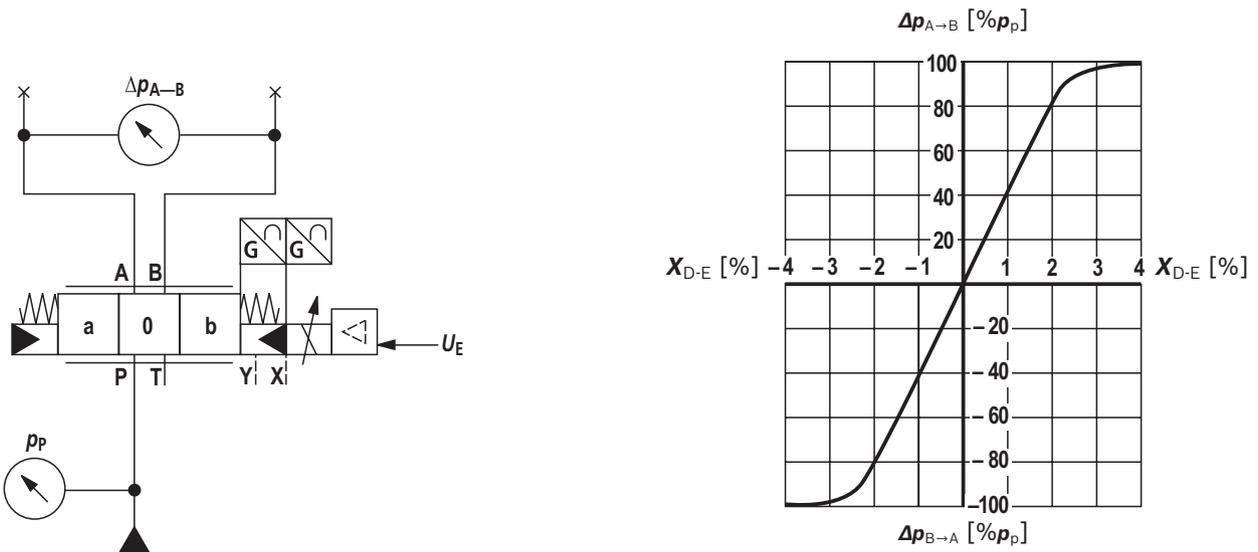

**Characteristic curves:** Size 10  
(measured with HLP46,  $\vartheta_{oil} = 40 \pm 5 \text{ }^\circ\text{C}$ )

**Transition function with stepped electric input signals**

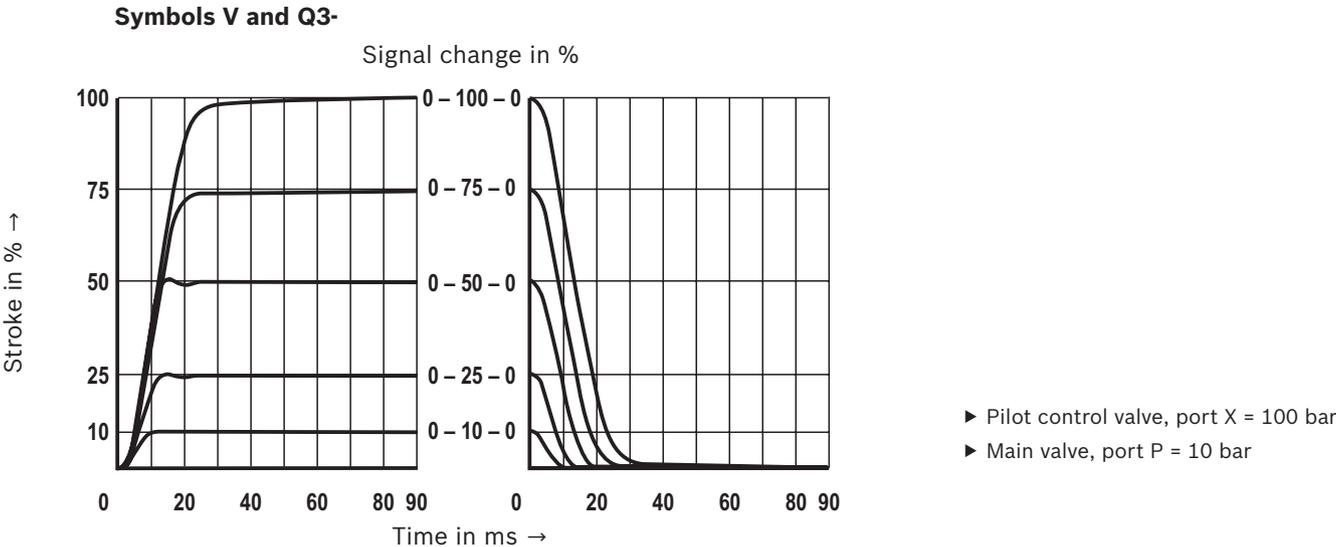

**Frequency response characteristic curves**

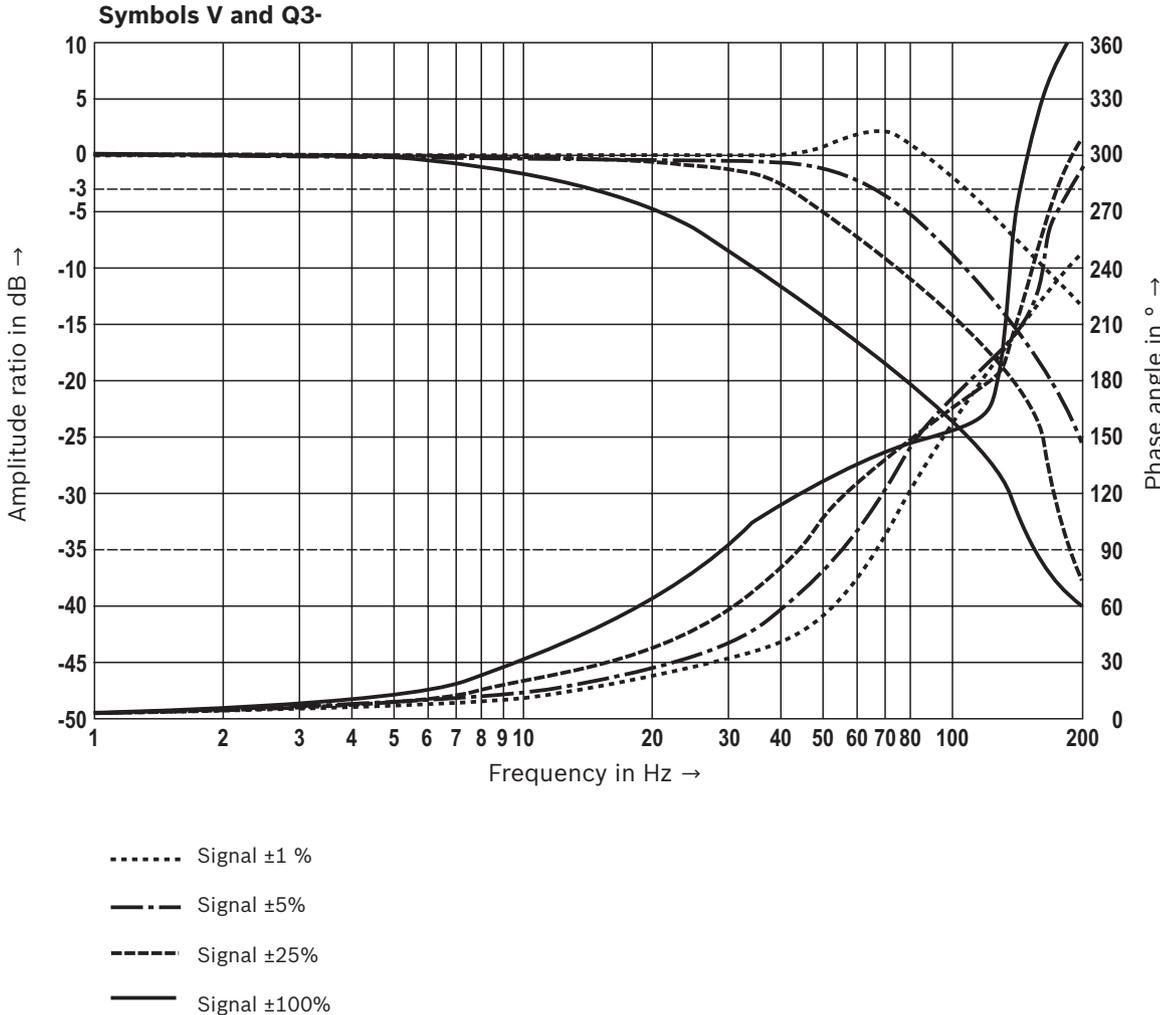

**Characteristic curves: Size 10**  
 (valid for HLP46,  $\vartheta_{oil} = 40 \pm 5 \text{ }^\circ\text{C}$ )

**Flow/load function with maximum valve opening** (with maximum valve opening; tolerance  $\pm 10\%$ )

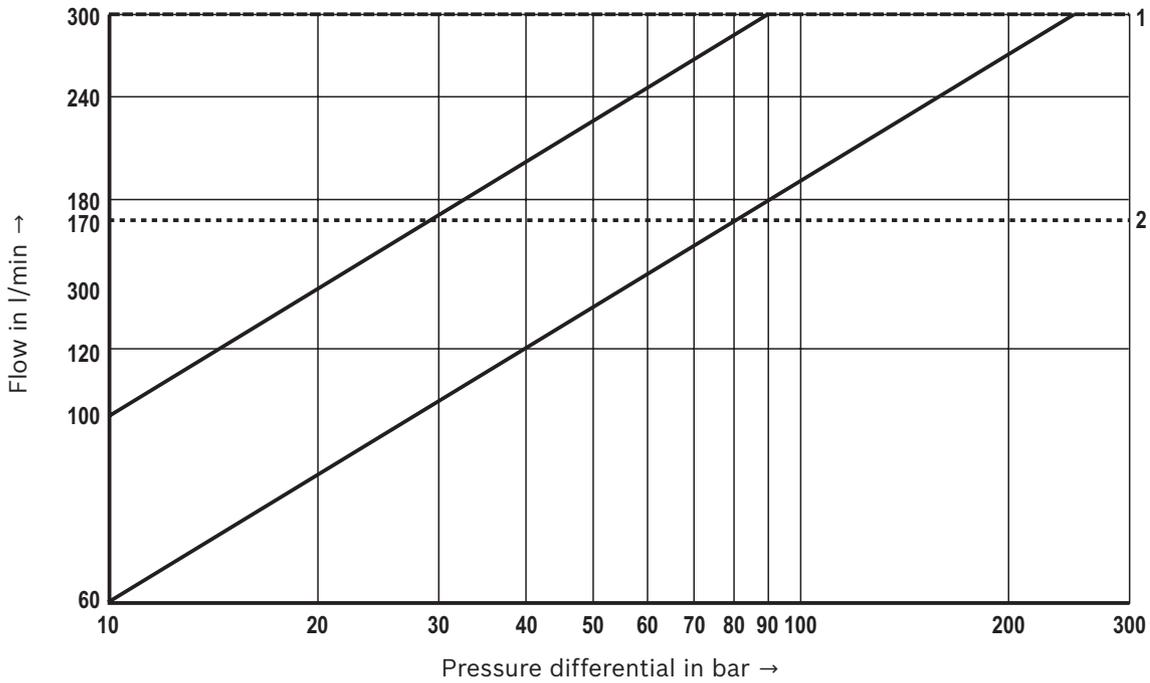

- 1 Maximum admissible flow
- 2 Recommended flow  
(flow velocity 30 m/s)

**Characteristic curves:** Size 16  
(measured with HLP46,  $\vartheta_{oil} = 40 \pm 5 \text{ }^\circ\text{C}$ )

**Transition function with stepped electric input signals**

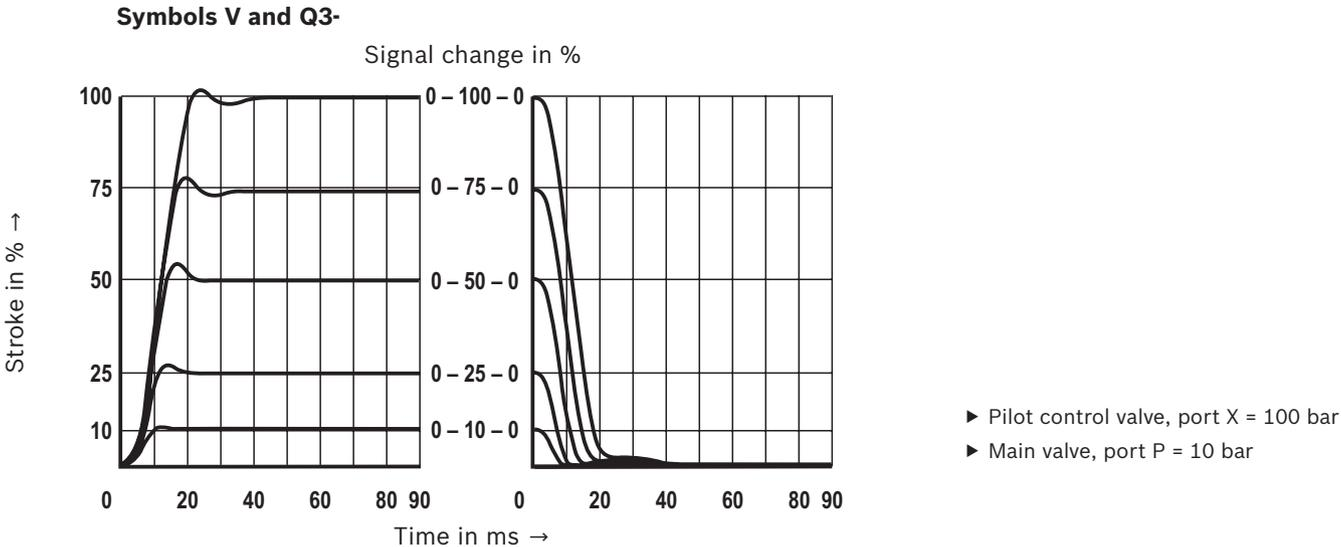

**Frequency response characteristic curves**

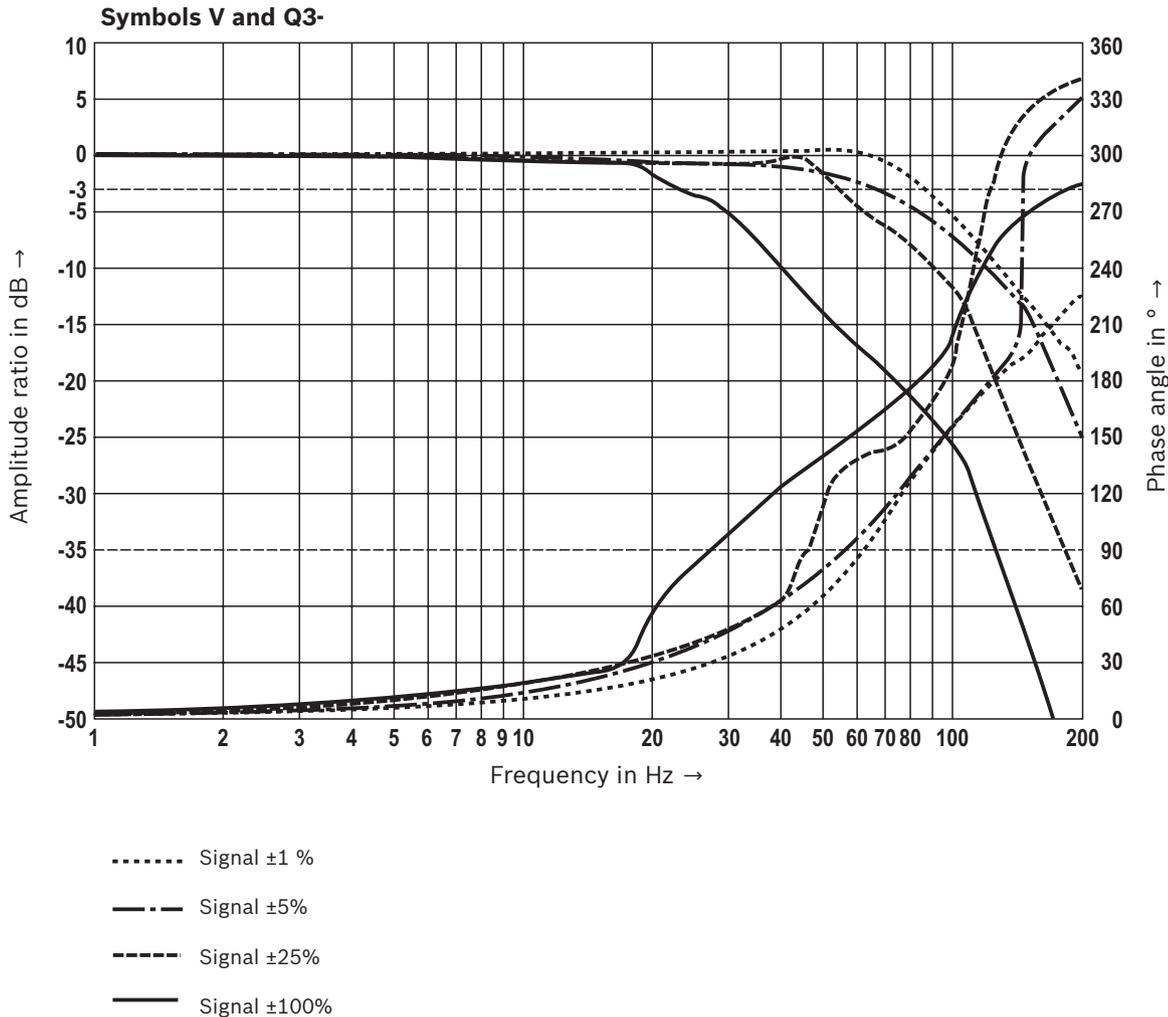

**Characteristic curves: Size 16**  
(valid for HLP46,  $\vartheta_{oil} = 40 \pm 5 \text{ }^\circ\text{C}$ )

**Flow/load function with maximum valve opening** (with maximum valve opening; tolerance  $\pm 10\%$ )

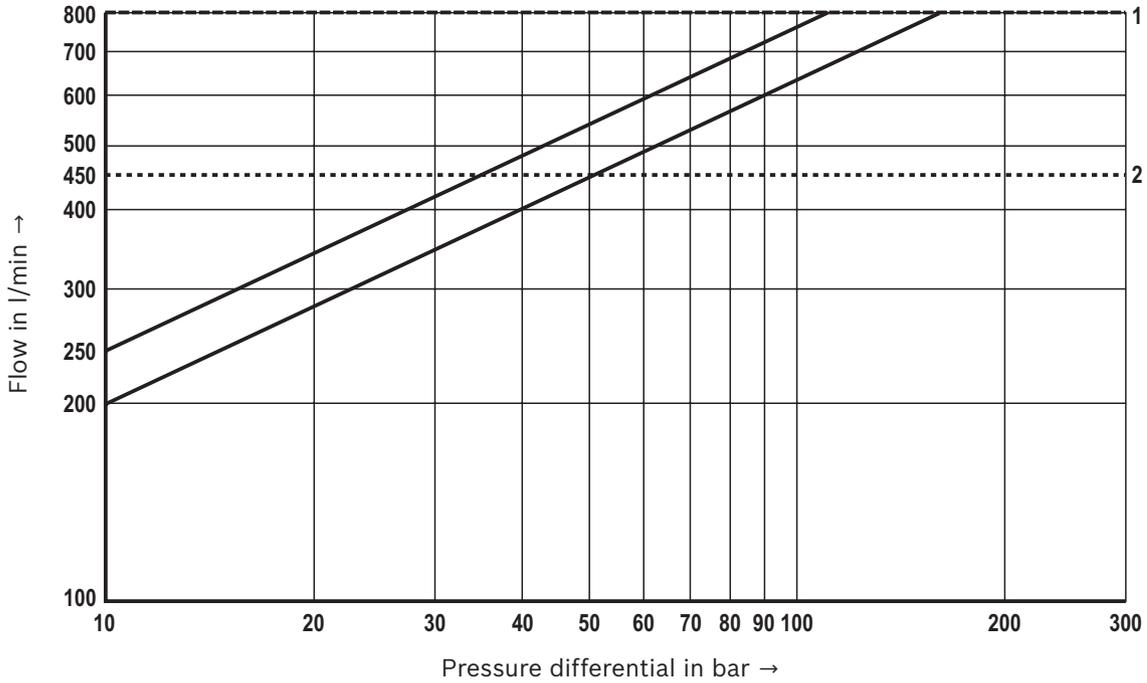

- 1 Maximum admissible flow
- 2 Recommended flow  
(flow velocity 30 m/s)

**Characteristic curves: Size 25**  
 (measured with HLP46,  $\vartheta_{oil} = 40 \pm 5 \text{ }^\circ\text{C}$ )

**Transition function with stepped electric input signals**

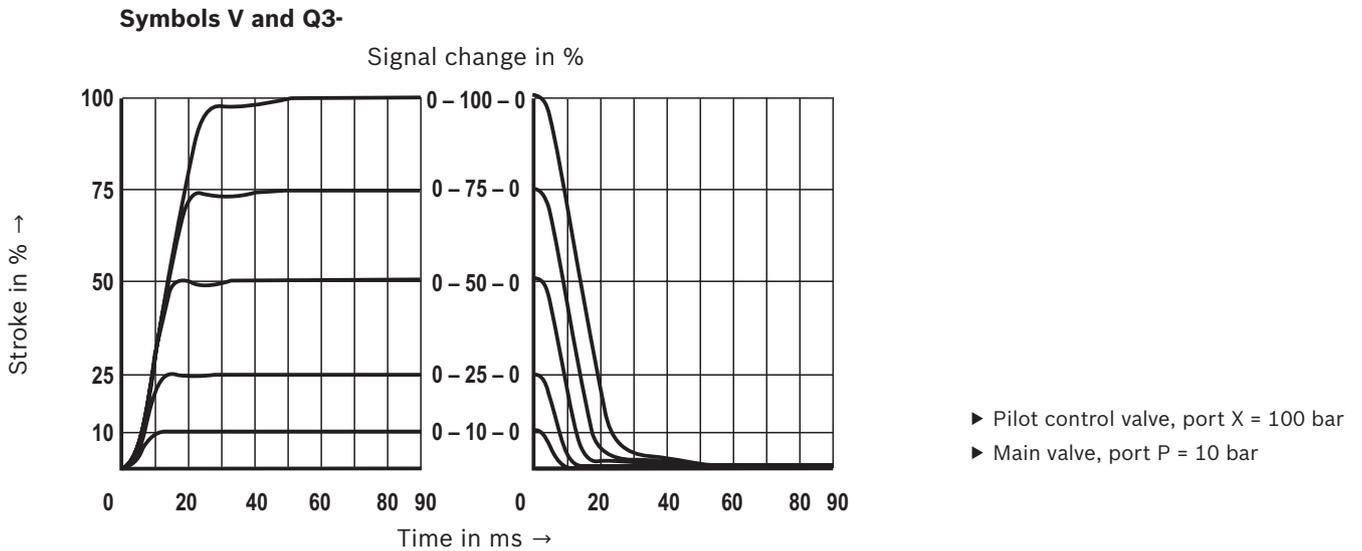

**Frequency response characteristic curves**

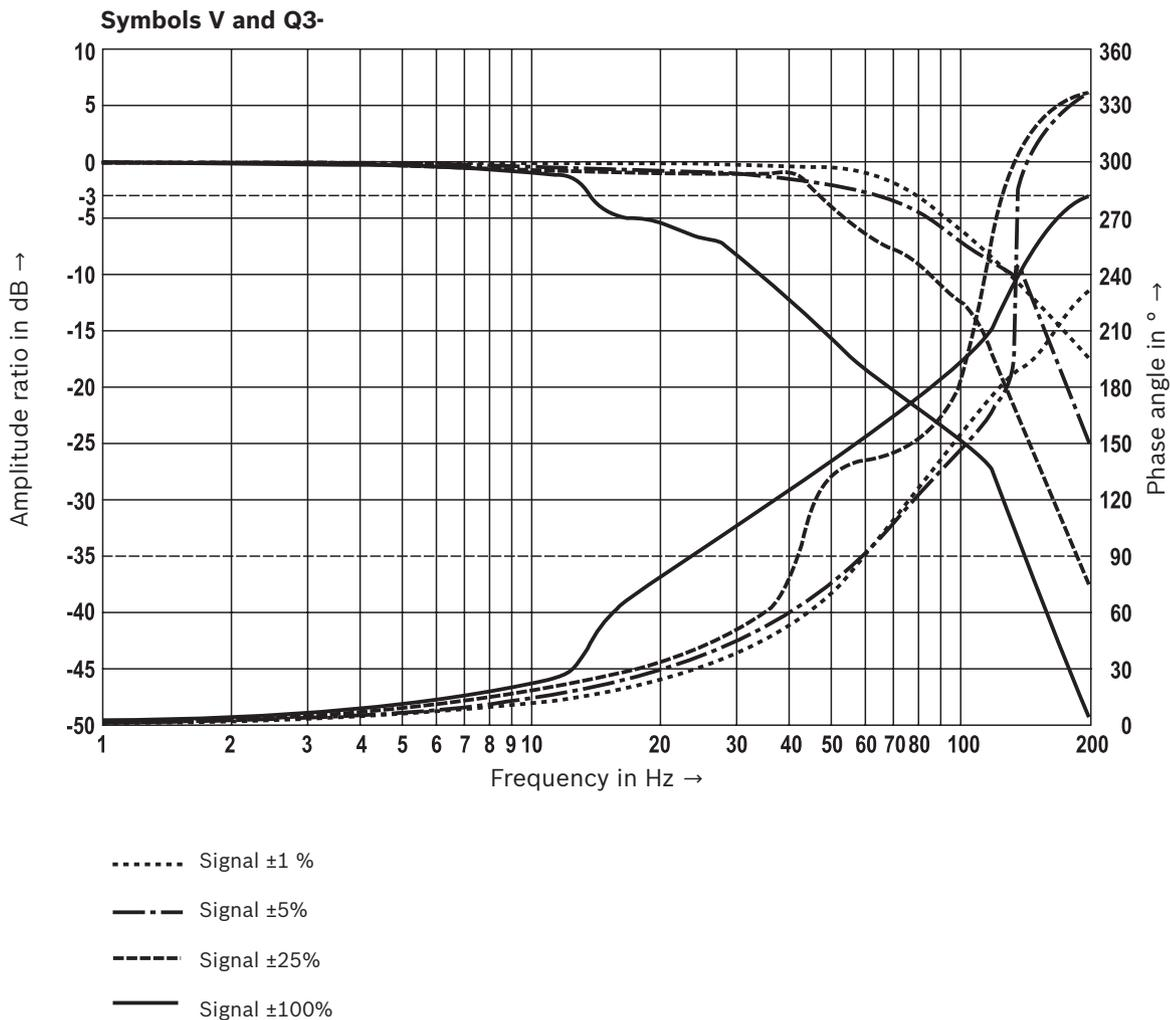

**Characteristic curves: Size 25**  
 (valid for HLP46,  $\vartheta_{oil} = 40 \pm 5 \text{ }^\circ\text{C}$ )

**Flow/load function with maximum valve opening** (with maximum valve opening; tolerance  $\pm 10\%$ )

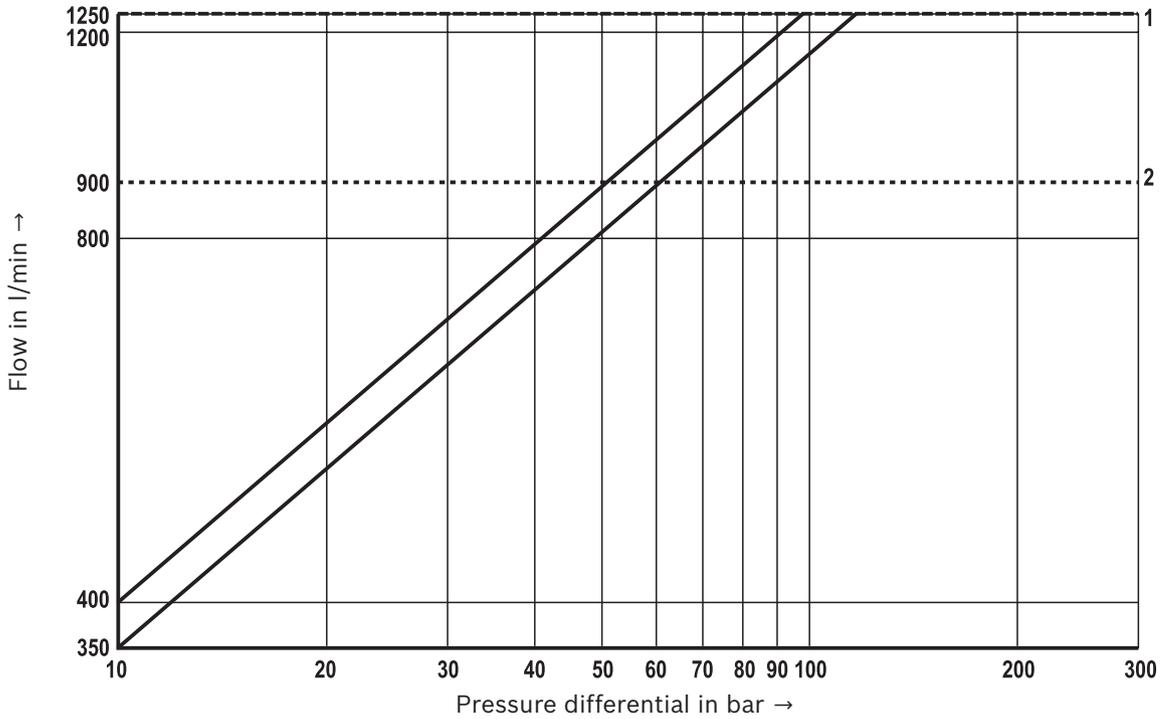

- 1 Maximum admissible flow
- 2 Recommended flow  
(flow velocity 30 m/s)

**Characteristic curves:** Size 27  
 (measured with HLP46,  $\vartheta_{oil} = 40 \pm 5 \text{ }^\circ\text{C}$ )

**Transition function with stepped electric input signals**

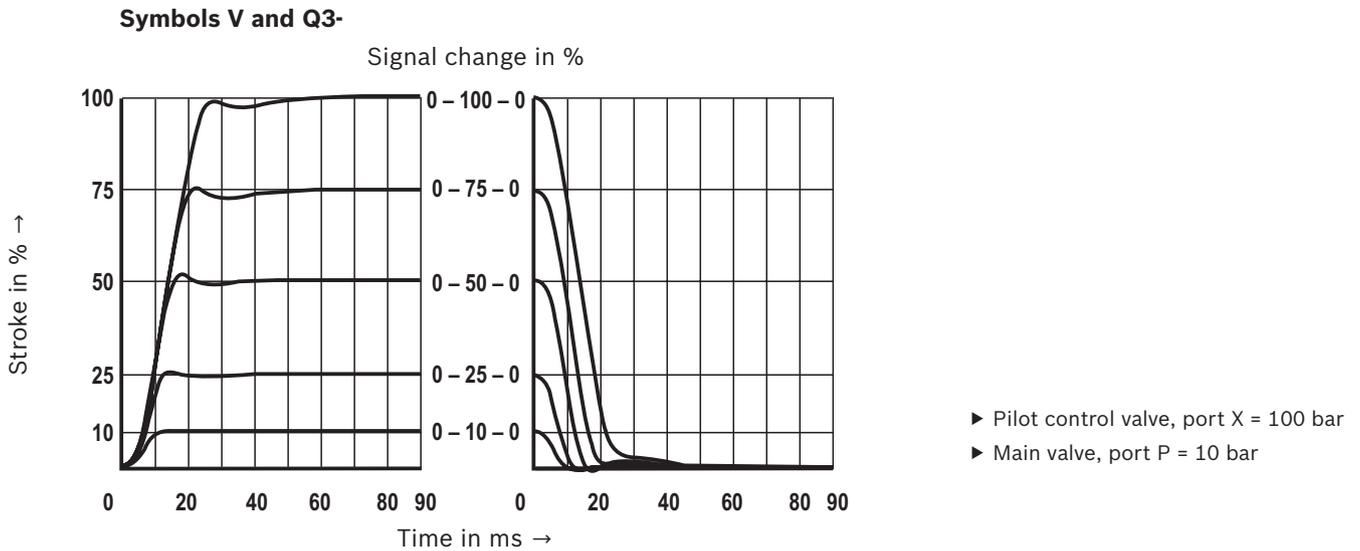

**Frequency response characteristic curves**

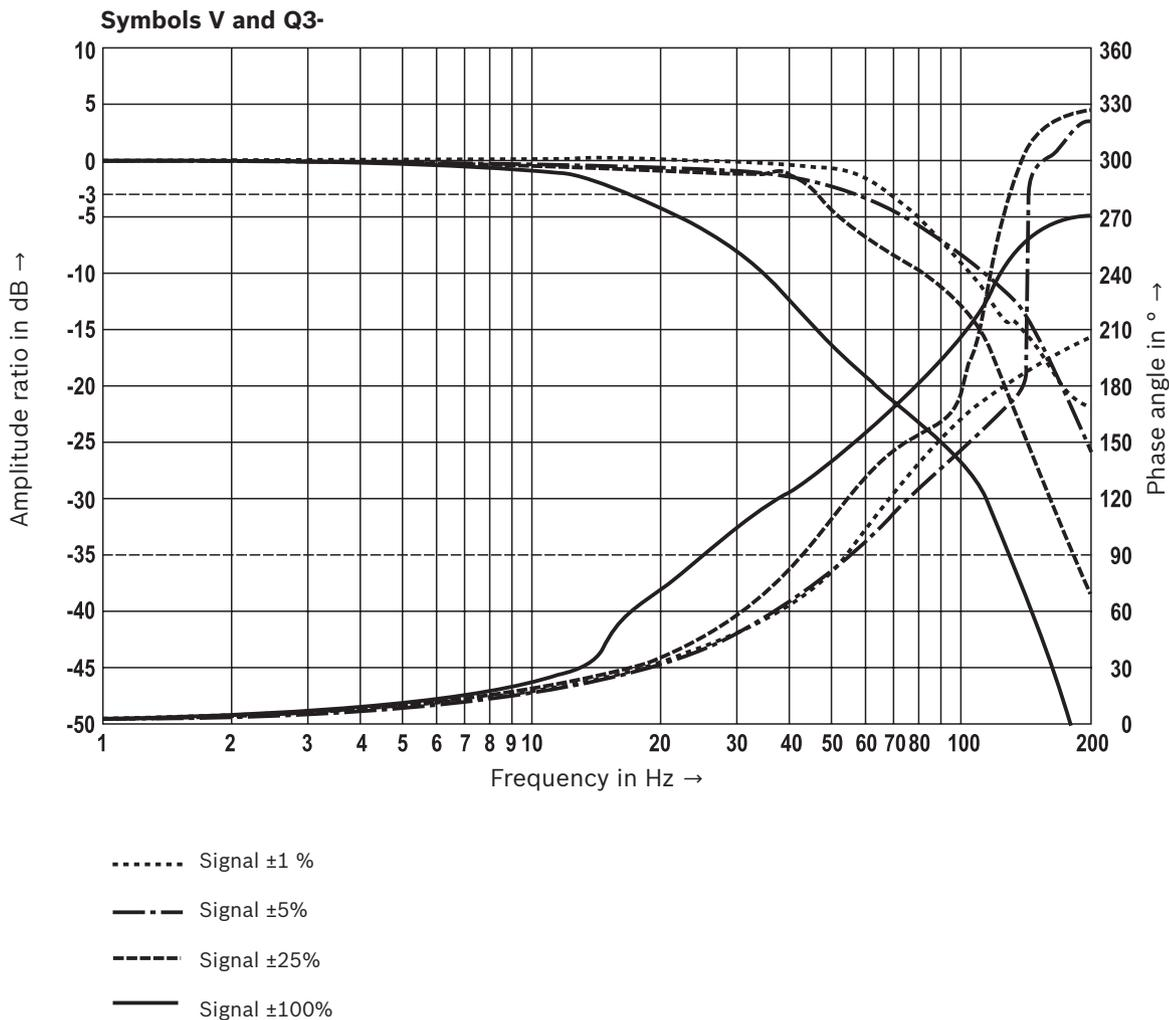

**Characteristic curves: Size 27**  
(valid for HLP46,  $\vartheta_{oil} = 40 \pm 5 \text{ }^\circ\text{C}$ )

**Flow/load function with maximum valve opening** (with maximum valve opening; tolerance  $\pm 10\%$ )

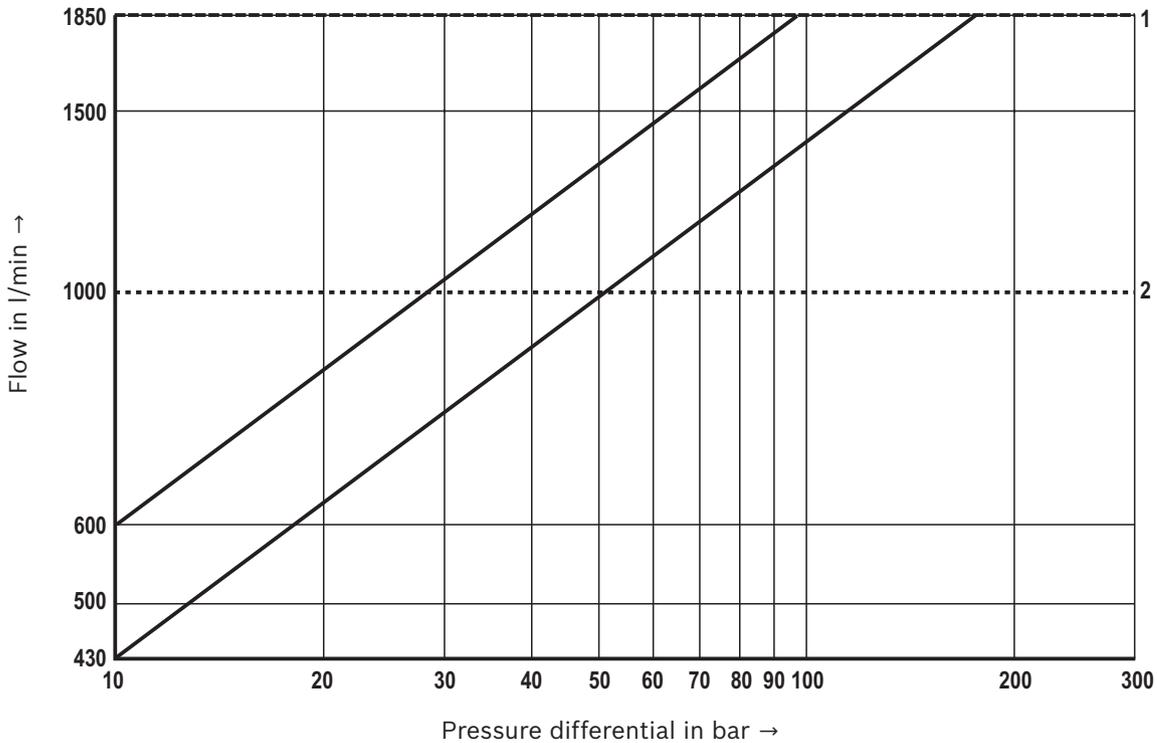

- 1 Maximum admissible flow
- 2 Recommended flow  
(flow velocity 30 m/s)

**Characteristic curves: Size 35**  
 (measured with HLP46,  $\vartheta_{oil} = 40 \pm 5 \text{ }^\circ\text{C}$ )

**Transition function with stepped electric input signals**

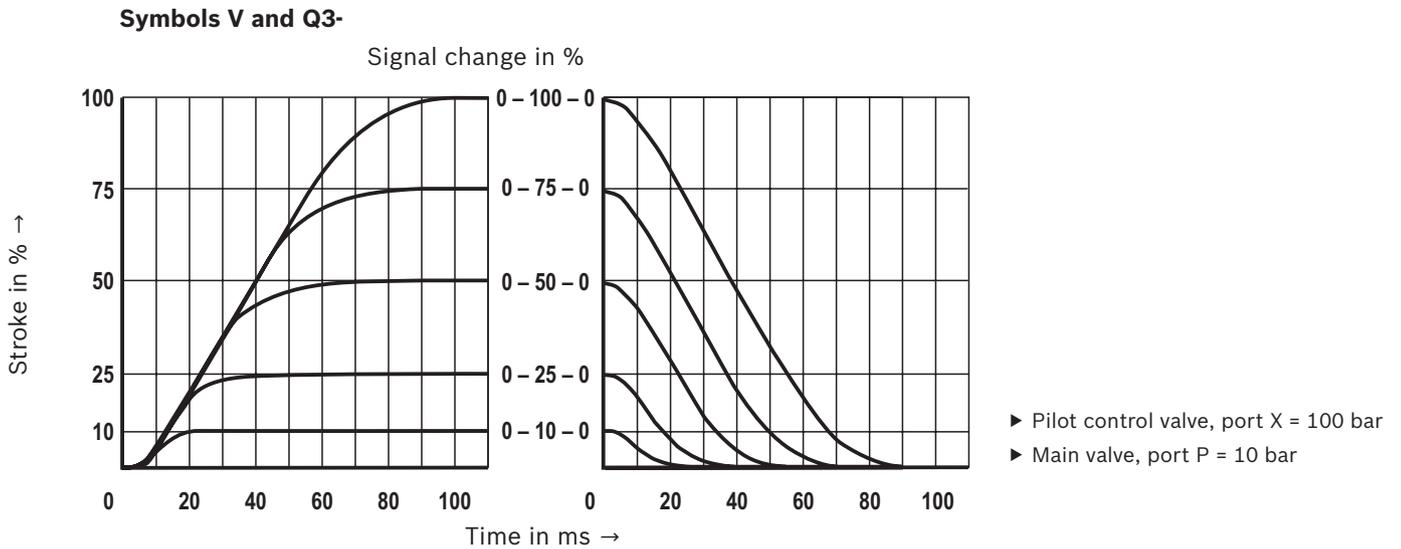

**Frequency response characteristic curves**

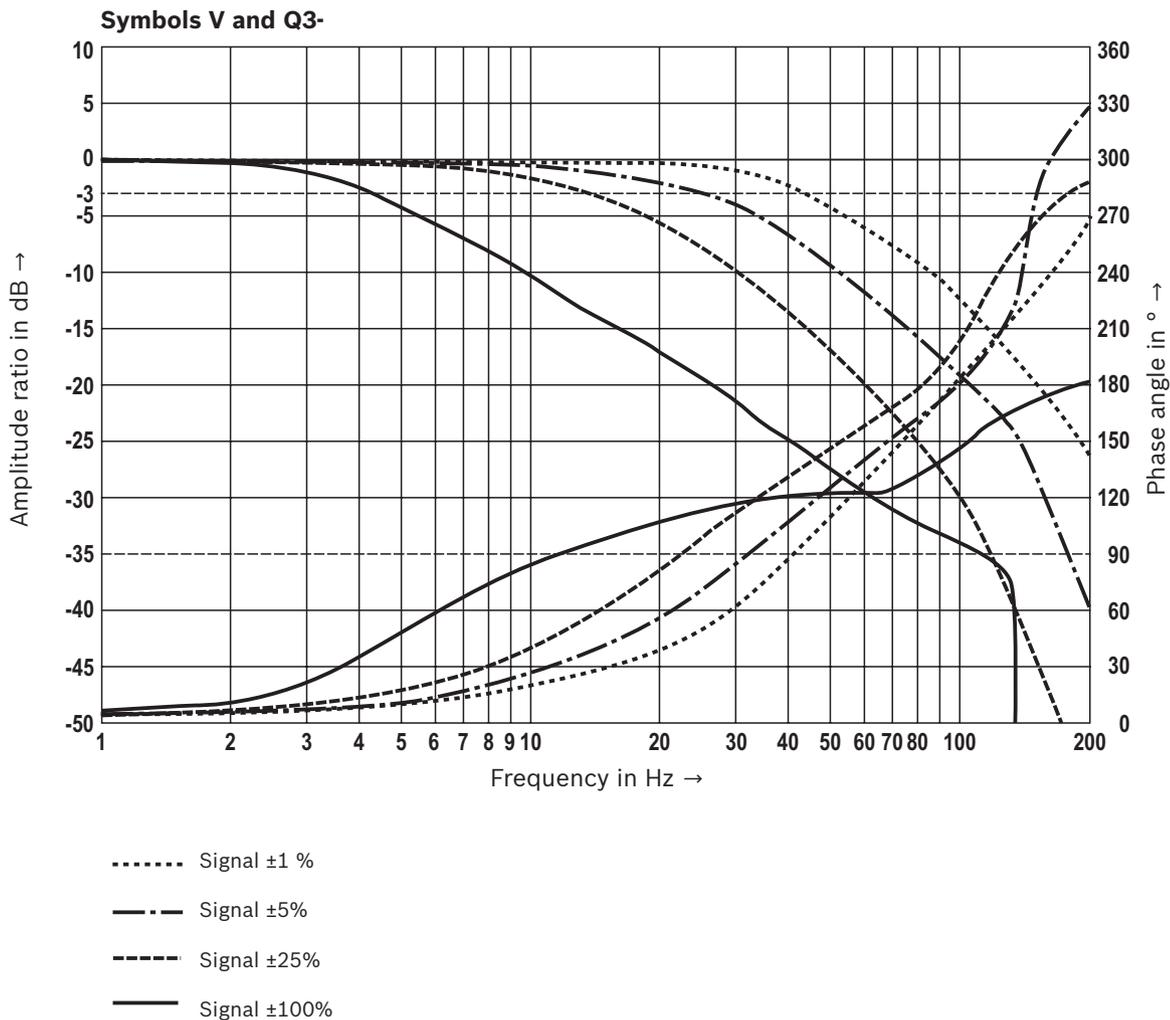

**Characteristic curves: Size 35**  
 (valid for HLP46,  $\vartheta_{oil} = 40 \pm 5 \text{ }^\circ\text{C}$ )

**Flow/load function with maximum valve opening** (with maximum valve opening; tolerance  $\pm 10\%$ )

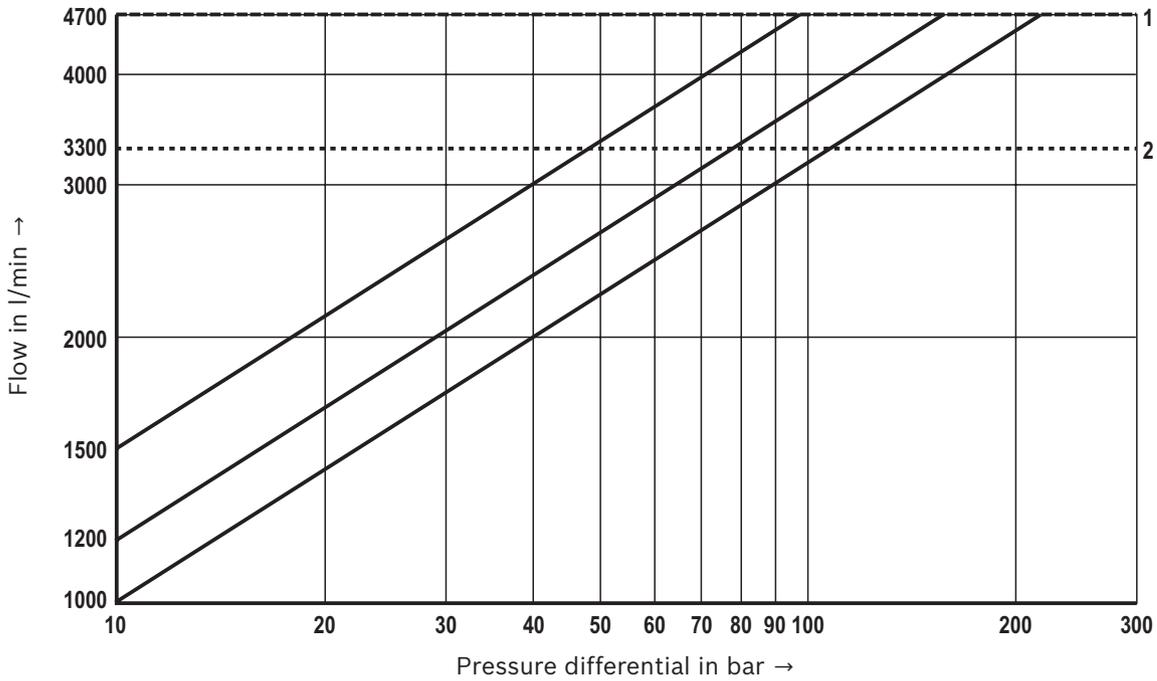

- 1 Maximum admissible flow
- 2 Recommended flow  
(flow velocity 30 m/s)

**Dimensions: Size 10**  
(dimensions in mm)

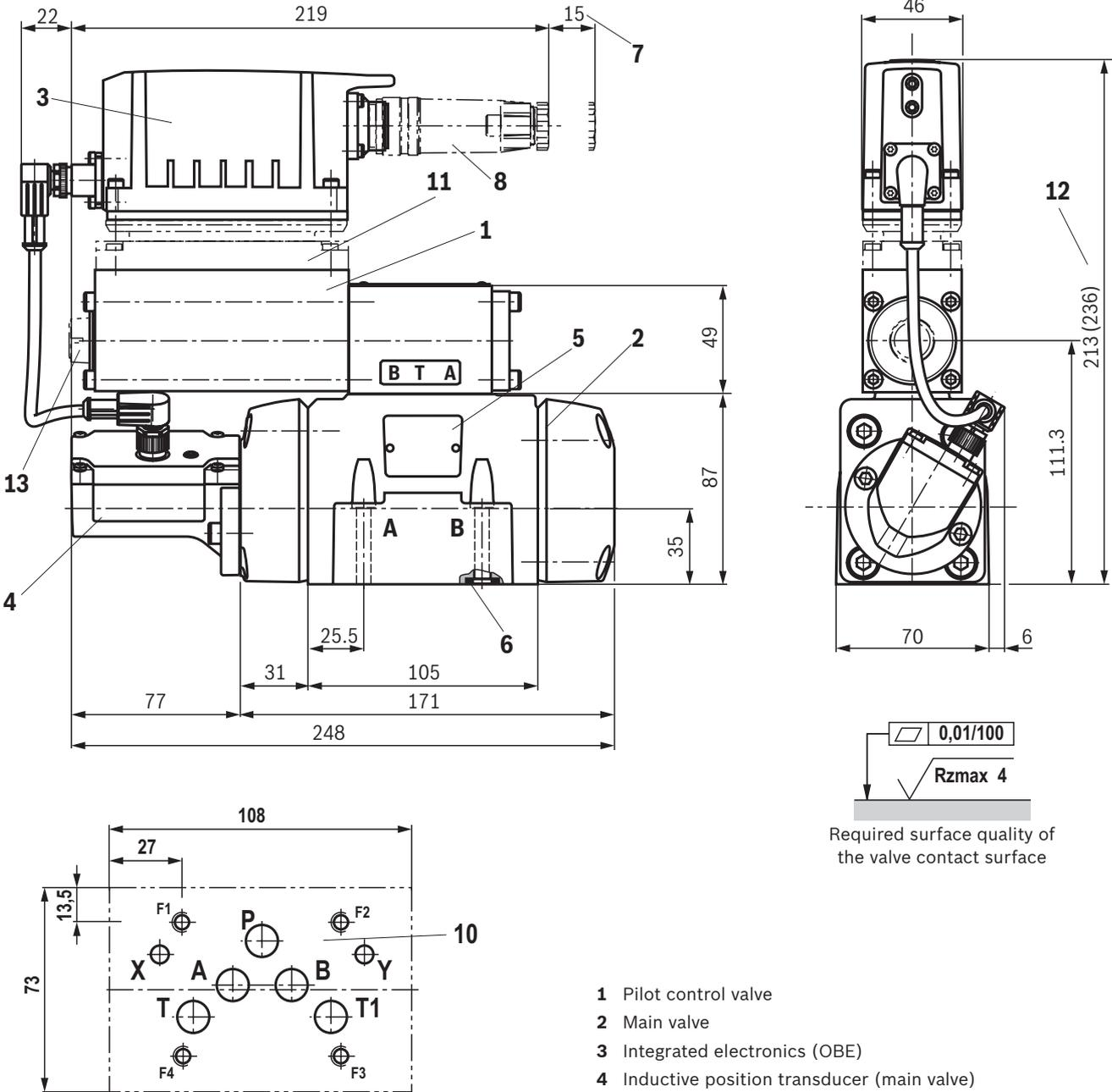

- 1 Pilot control valve
- 2 Main valve
- 3 Integrated electronics (OBE)
- 4 Inductive position transducer (main valve)
- 5 Name plate
- 6 Identical seal rings for ports P, A, B, T;  
Identical seal rings for ports X, Y
- 7 Space required for removing the mating connector
- 8 Mating connectors, separate order, see page 36 and data sheet 08006.
- 9 Locking pin
- 10 Machined valve contact surface,  
porting pattern according to ISO 4401-05-05-0-05
- 11 Damping plate "D"
- 12 Dimension in ( ) for version with damping plate "D"
- 13 Electronics protection membrane "-967"

**Valve mounting screws and subplates**, see page 35.

**Notes:**  
The dimensions are nominal dimensions which are subject to tolerances.

**Dimensions: Size 16**  
(dimensions in mm)

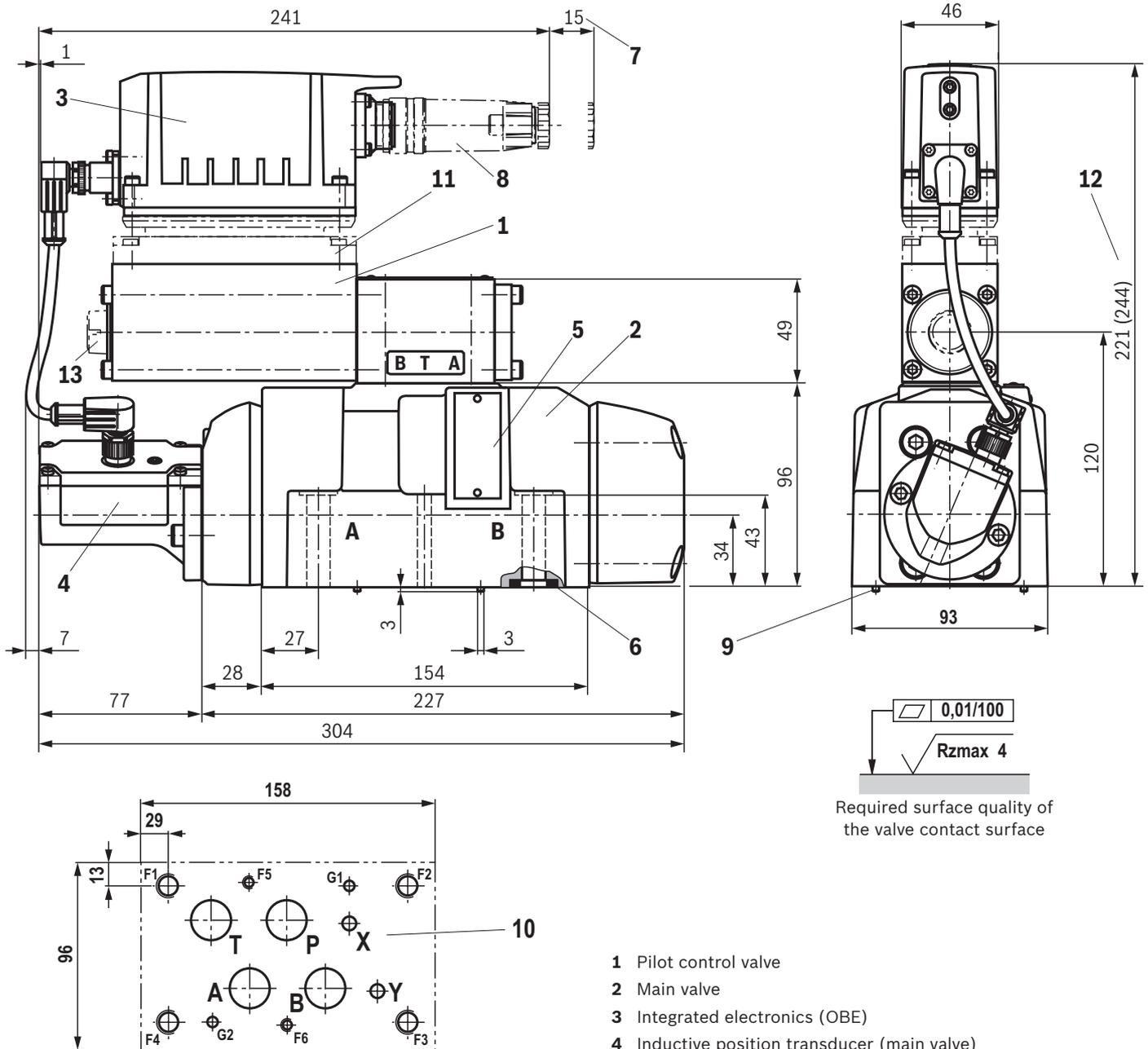

Required surface quality of the valve contact surface

**Valve mounting screws and subplates**, see page 35.

**Notes:**  
The dimensions are nominal dimensions which are subject to tolerances.

- 1 Pilot control valve
- 2 Main valve
- 3 Integrated electronics (OBE)
- 4 Inductive position transducer (main valve)
- 5 Name plate
- 6 Identical seal rings for ports P, A, B, T;  
Identical seal rings for ports X, Y
- 7 Space required for removing the mating connector
- 8 Mating connectors, separate order, see page 36 and data sheet 08006.
- 9 Locking pin
- 10 Machined valve contact surface,  
porting pattern according to ISO 4401-07-07-0-05  
Deviating from the standard:  
Ports P, A, B, T – Ø20 mm
- 11 Damping plate "D"
- 12 Dimension in ( ) for version with damping plate "D"
- 13 Electronics protection membrane "-967"

**Dimensions: Size 25 and 27**  
(dimensions in mm)

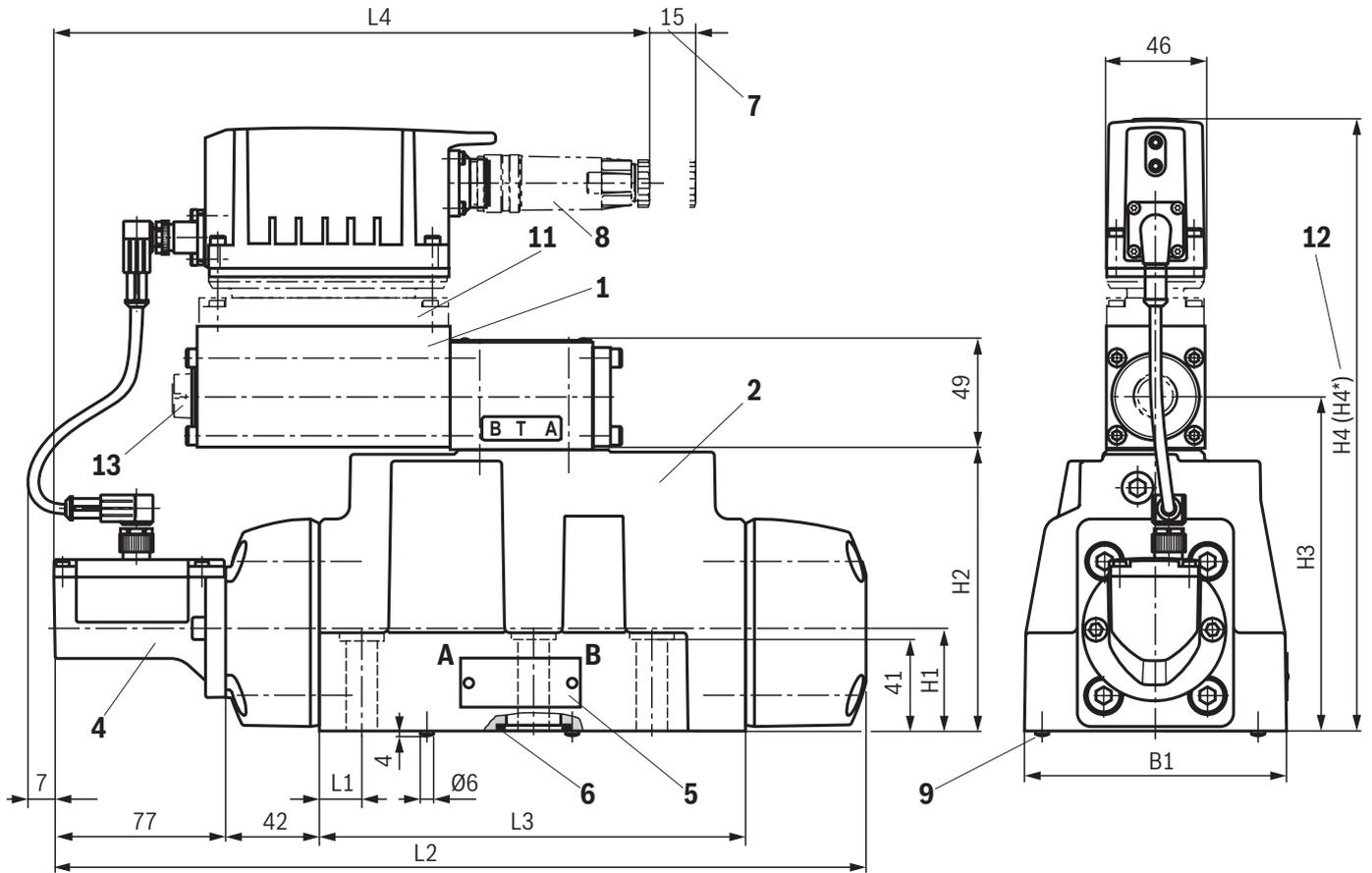

0,01/100  
Rzmax 4  
Required surface quality of the valve contact surface

- 1 Pilot control valve
- 2 Main valve
- 3 Integrated electronics (OBE)
- 4 Inductive position transducer (main valve)
- 5 Name plate
- 6 Identical seal rings for ports P, A, B, T; Identical seal rings for ports X, Y
- 7 Space required for removing the mating connector
- 8 Mating connectors, separate order, see page 36 and data sheet 08006.
- 9 Locking pin
- 10 Machined valve contact surface, porting pattern according to ISO 4401-08-08-05  
Deviating from the standard:  
► NG27: Ports P, A, B, T – Ø32 mm
- 11 Damping plate "D"
- 12 Dimension in (\*) for version with damping plate "D"
- 13 Electronics protection membrane "-967"

NG	L1	L2	L3	L4	H1	H2	H3	H4	H4*	H5	B1	B2
25	19	364	191	274	46	126	150	251	274	120	118	195
27	20.5	371	198	277	50	140	164	265	288	124	120	200

**Valve mounting screws and subplates**, see page 35.

**Notes:**

The dimensions are nominal dimensions which are subject to tolerances.

**Dimensions: Size 35**  
(dimensions in mm)

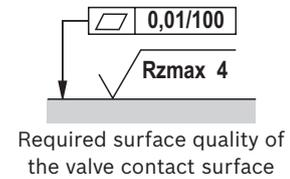
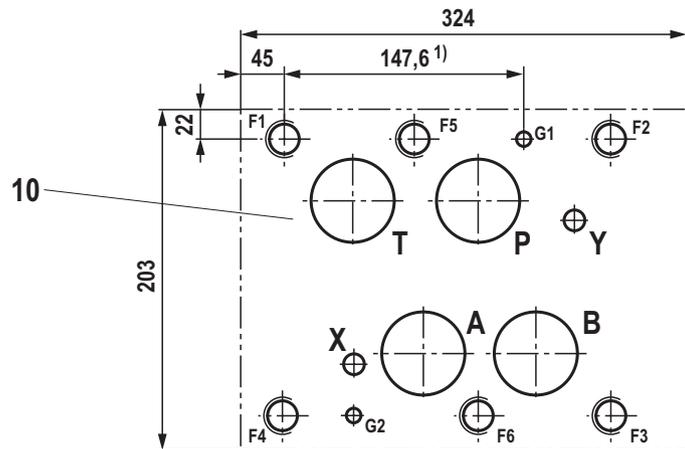
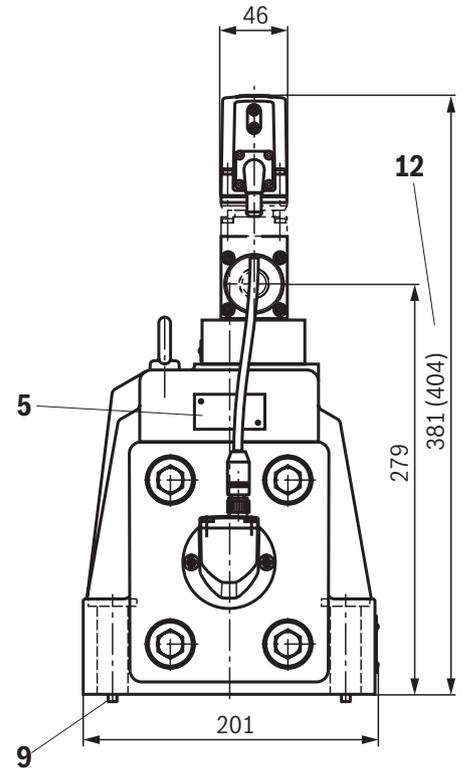
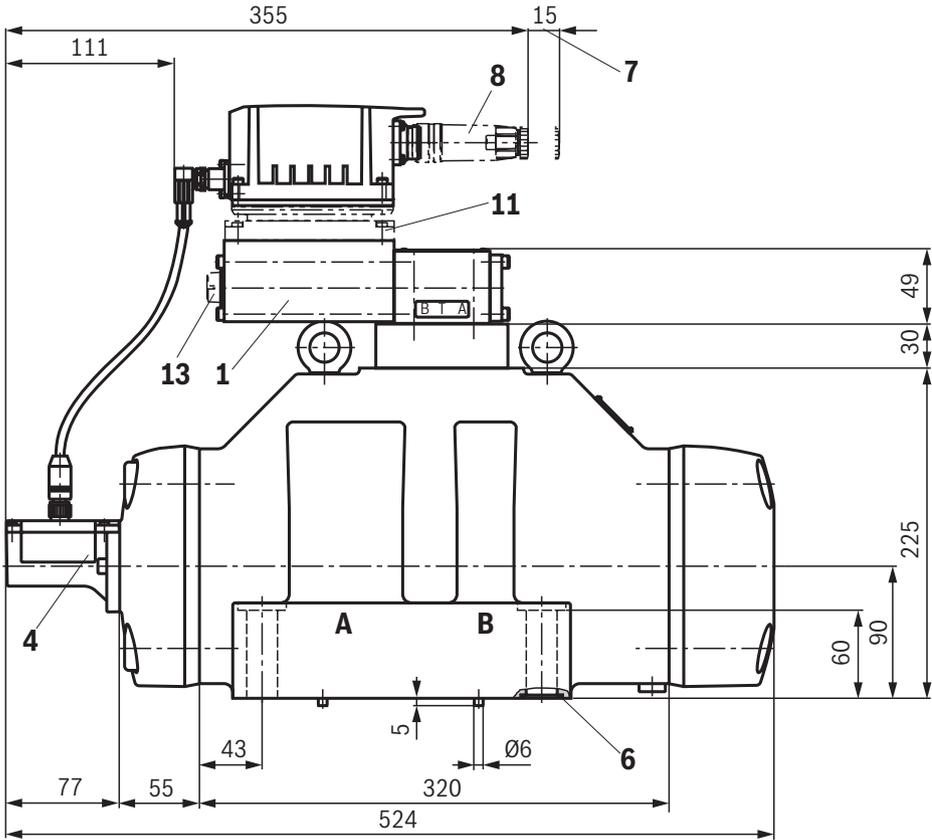

- 1 Pilot control valve
- 2 Main valve
- 3 Integrated electronics (OBE)
- 4 Inductive position transducer (main valve)
- 5 Name plate
- 6 Identical seal rings for ports P, A, B, T;  
Identical seal rings for ports X, Y
- 7 Space required for removing the mating connector
- 8 Mating connectors, separate order, see page 36 and data sheet 08006.
- 9 Locking pin
- 10 Machined valve contact surface, porting pattern according to ISO 4401-10-09-0-05  
Deviating from the standard:  
Ports P, A, B, T – Ø50 mm  
1) Position G1 according to DIN 24340 Form A
- 11 Damping plate "D"
- 12 Dimension in ( ) for version with damping plate "D"
- 13 Electronics protection membrane "-967"

**Valve mounting screws and subplates**, see page 35.

**Notes:**  
The dimensions are nominal dimensions which are subject to tolerances.

## Dimensions

### Valve mounting screws (separate order)

Size	Quantity	Hexagon socket head cap screws	Material number
10	4	ISO 4762 - M6 x 45 - 10.9-CM-Fe-ZnNi-5-Cn-T0-H-B tightening torque $M_A = 13.5 \text{ Nm} \pm 10\%$	R913043777
	or		
	4	ISO 4762 - M6 x 45 - 10.9 tightening torque $M_A = 15.5 \text{ Nm} \pm 10\%$	Not included in the Rexroth delivery range
16	2	ISO 4762 - M6 x 60 - 10.9-CM-Fe-ZnNi-5-Cn-T0-H-B tightening torque $M_A = 12.2 \text{ Nm} \pm 10\%$	R913043410
	4	ISO 4762 - M10 x 60 - 10.9-fIZn/nc/480h/C tightening torque $M_A = 58 \text{ Nm} \pm 20\%$	R913014770
	or		
	2	ISO 4762 - M6 x 60 - 10.9 tightening torque $M_A = 15.5 \text{ Nm} \pm 10\%$	Not included in the Rexroth delivery range
4	ISO 4762 - M10 x 60 - 10.9 tightening torque $M_A = 75 \text{ Nm} \pm 20\%$		
25, 27	6	ISO 4762 - M12 x 60 - 10.9-fIZn/nc/480h/C tightening torque $M_A = 100 \text{ Nm} \pm 20\%$	R913015613
	or		
	6	ISO 4762 - M12 x 60 tightening torque $M_A = 130 \text{ Nm} \pm 20\%$	Not included in the Rexroth delivery range
35	6	ISO 4762 - M20 x 90 - 10.9-fIZn/nc/480h/C tightening torque $M_A = 465 \text{ Nm} \pm 20\%$	R913009160
	or		
	6	ISO 4762 - M20 x 90 - 10.9 tightening torque $M_A = 610 \text{ Nm} \pm 20\%$	Not included in the Rexroth delivery range

#### Notice:

- ▶ The tightening torque of the hexagon socket head cap screws refers to the maximum operating pressure.
- ▶ **When replacing component series 3X with 4X, only the valve mounting screws listed here may be used. Prior to assembly, check the existing mounting bore on the block for sufficient screw-in depth.**

**Subplates** (separate order) with porting pattern according to ISO 4401 see data sheet 45100.

**Accessories** (separate order)**Valve with integrated electronics**

Mating connectors 6-pole + PE	Design	Version	Material number	Data sheet
For the connection of valves with integrated electronics, round connector 6+PE, line cross-section 0.5 ... 1.5 mm <sup>2</sup>	straight	Metal	<b>R900223890</b>	08006
	straight	Plastic	<b>R900021267</b>	08006
	angled	Plastic	<b>R900217845</b>	–

Cable sets 6-pole + PE	Length in m	Material number	Data sheet
For the connection of valves with integrated electronics, round connector 6+PE, straight connector, shielded, potted-in mating connector, line cross-section 0.75 mm <sup>2</sup>	3.0	<b>R901420483</b>	08006
	5.0	<b>R901420491</b>	08006
	10.0	<b>R901420496</b>	08006
	20.0	<b>R901448068</b>	–

**Test and service device**

	Material number	Data sheet
Service case with test device for proportional servo valves with integrated electronics (OBE)		29685

**Further information**

▶ Subplates	Data sheet 45100
▶ Hydraulic fluids on mineral oil basis	Data sheet 90220
▶ Environmentally compatible hydraulic fluids	Data sheet 90221
▶ Flame-resistant, water-free hydraulic fluids	Data sheet 90222
▶ Flame-resistant hydraulic fluids - containing water (HFAE, HFAS, HFB, HFC)	Data sheet 90223
▶ Reliability characteristics according to EN ISO 13849	Data sheet 08012
▶ Hexagon socket head cap screw, metric/UNC	Data sheet 08936
▶ General product information on hydraulic products	Data sheet 07008
▶ Installation, commissioning and maintenance of servo valves and high-response valves	Data sheet 07700
▶ Hydraulic valves for industrial applications	Data sheet 07600-B
▶ Assembly, commissioning and maintenance of hydraulic systems	Data sheet 07900
▶ Selection of the filters	<a href="http://www.boschrexroth.com/filter">www.boschrexroth.com/filter</a>
▶ Information on available spare parts	<a href="http://www.boschrexroth.com/spc">www.boschrexroth.com/spc</a>

Bosch Rexroth AG  
 Industrial Hydraulics  
 Zum Eisengießer 1  
 97816 Lohr am Main, Germany  
 Phone +49 (0) 93 52/40 30 20  
[my.support@boschrexroth.de](mailto:my.support@boschrexroth.de)  
[www.boschrexroth.de](http://www.boschrexroth.de)

© This document, as well as the data, specifications and other information set forth in it, are the exclusive property of Bosch Rexroth AG. It may not be reproduced or given to third parties without its consent.  
 The data specified above only serve to describe the product. No statements concerning a certain condition or suitability for a certain application can be derived from our information. The information given does not release the user from the obligation of own judgment and verification. It must be remembered that our products are subject to a natural process of wear and aging.