

Hydrostatic Pump Repair

www.hydrostaticpumprepair.net

Phone: 800-361-0028

Email: sales@hydrostatic-transmission.com

Rexroth
Bosch Group

Axial piston pump-variable with electro-hydraulic pressure control A10V(S)O... ED../ER..

RE 92707/03.08 1/8
replaces : 06.03

Data sheet

for variable pump
A10V(S)O series 31; 32
A10VO series 52; 53
open circuit operation

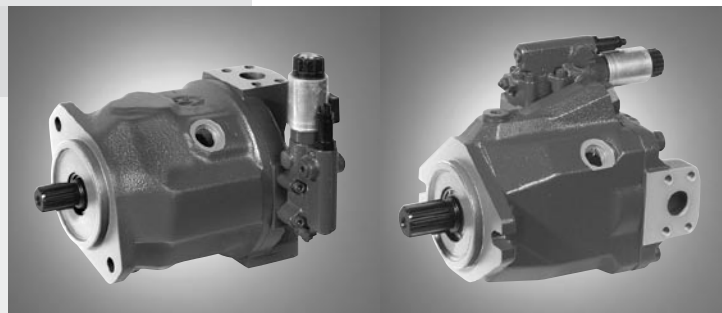

A10V(S)O...ED/3x

A10VO...ED/5x

Content

Type code / Standard program series 3x	2
Type code / Standard program series 5x	3
ED - Electro-hydraulic pressure control for A10V(S)O series 3x	4
ED - Electro-hydraulic pressure control for A10VO series 5x	5
Dimensions A10V(S)O series 3x	6
Dimensions A10VO series 5x	6
Solenoid connectors	7
Electronic controls	7
General information	8

Features

- Electro-hydraulic pressure control, current dependent
- High control accuracy
- Fail safe characteristic in case of power failure e.g. ED-applications for hydraulic fan drives
- Compatible with the use of standard proportional amplifiers

Further information:

Variable pump A10VSO/31	RE 92711
	RE 92712
Variable pump A10VSO/32	RE 92714
Variable pump A10VO/31	RE 92701
Variable pump A10VO/52; 53	RE 92703

Type code / Standard program series 3x

A10V(S)	O				/	3x		-						
01	02	03	04	05		06	07		08	09	10	11	12	13

		18	28	45	71	100	140	
01	Axial piston unit	●	–	–	–	–	–	A10VS
	Swash plate design, variable	–	●	●	●	●	●	A10V

Mode of operation		
02	Pump, open circuit	O

Size		18	28	45	71	100	140
03	≈ Displacement $V_{g \max}$ in cm^3						

Control devices		18	28	45	71	100	140	
04	Electro- hydraulic pressure control (inverse proportional I-p characteristic)	●	●	●	●	●	●	ED
	Electro-hydraulic pressure control (proportional I-p characteristic)	○	○	○	○	○	○	ER

Nominal voltage (V)		Nominal current I_N (A)		18	28	45	71	100	140	
05	12	1,2		●	●	●	●	●	●	71
	24	0,6		●	●	●	●	●	●	72

Series		18	28	45	71	100	140	
06	Series 3	●	●	●	●	●	●	31
	Index 1	–	○	○	●	●	●	32

For all further information regarding type code items 07 to 12 please consult the data sheets RE 92701, 92711, 92712 and 92714.

Solenoid connectors		18	28	45	71	100	140	
13	HIRSCHMANN-plug – without suppressor diode (not for new applications)	●	●	●	●	●	●	H
	DEUTSCH – plug, permanently moulded, 2-pole – without suppressor diode	●	●	●	●	●	●	P

● = available ○ = in preparation – = not available

Type code / Standard program series 5x

A10V	O				/	5x	-							
01	02	03	04	05		06	07		08	09	10	11	12	13

Axial piston unit

01	Swash plate design, variable	A10V
----	------------------------------	-------------

Mode of operation

02	Pump, open circuit	O
----	--------------------	----------

Size

03	≈ Displacement $V_{g\max}$ in cm^3	18	28	45	63	85
----	---	-----------	-----------	-----------	-----------	-----------

Control devices

04	Electro-hydraulic pressure control (inverse proportional I-p characteristic)	●	●	●	●	●	ED
	Electro-hydraulic pressure control (proportional I-p characteristic)	○	○	○	○	○	ER

Nominal voltage (V)**Nominal current I_N (A)**

05	12	1,2	●	●	●	●	●	71
	24	0,6	●	●	●	●	●	72

Series

06	Series 5	Index 2	-	●	●	●	●	52
		Index 3	●	○	○	○	○	53

For all further information regarding type code items 07 to 12 please consult the data sheet RE 92703.

Solenoid connectors

13	HIRSCHMANN-plug – without suppressor diode (not for new applications)	●	●	●	●	●	H
	DEUTSCH – plug, permanently moulded, 2-pole – without suppressor diode	●	●	●	●	●	P

● = available ○ = in preparation - = not available

ED - Electro-hydraulic pressure control for A10V(S)O series 3x

The max. pump output pressure is set through a command current signal to the ED-valve solenoid

When system pressure (load pressure) reaches this pressure level, the pump's control valve spool shifts and causes an increase or decrease in the pump's swivel angle (flow) in order to maintain this set pressure level.

The pump output flow matches the needed input flow to the actuators. The desired pressure level can be set steplessly by varying the solenoid current.

When the solenoid current signal drops towards a zero value, the max. output pressure is limited by an adjustable mechanical pressure cut off (secure fail safe function in case of a loss of power e.g. for use as fan drives).

Influence of pressure setting on standby level

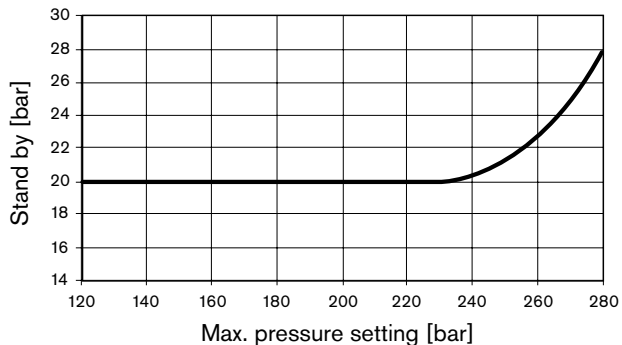

Static current-pressure characteristic (inverse proportional characteristic)

(measured with pump in standby)

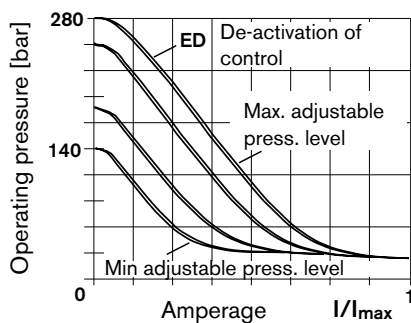

Hysteresis of static current-press. characteristic < 3bar

Schematic A10V(S)O...ED../3x

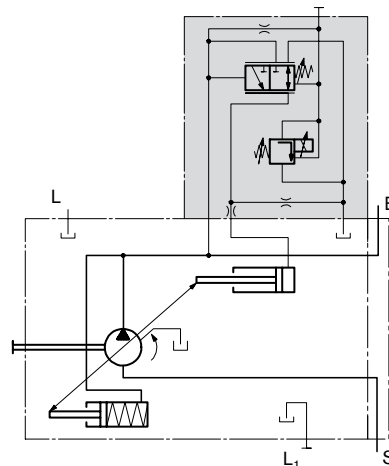

Ports

- B Pressure port
- S Suction port
- L, L₁ Case drain port (L₁ plugged)

Pilot flow consumption: 3 - 4,5 L/min.

Static flow-pressure characteristic

(at n = 1500rpm; t_{fluid} = 50°C)

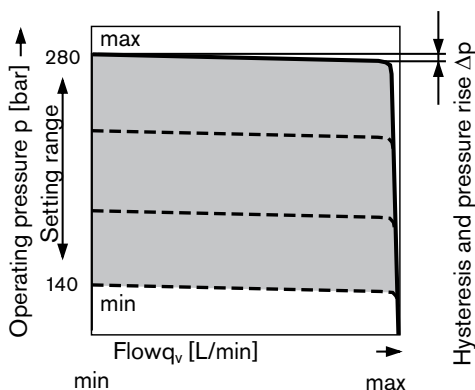

Control data

Standard standby setting 20bar, other values on request.

Hysteresis and pressure rise $\Delta p < 4$ bar.

Technical data, solenoids	ED71	ED72
Voltage	12 V (± 20 %)	24 V (± 20 %)
Control current		
Beg. of control at $q_{v \min}$	100 mA	50 mA
End of control at $q_{v \max}$	1200 mA	600 mA
Limit current	1,54 A	0,77 A
Nominal resistance (at 20°C)	5,5 Ω	22,7 Ω
Dither frequency	100 - 200 Hz	100 - 200 Hz
Duty cycle	100 %	100 %
Solenoid class of material	H (T _{max} = 180°C)	
Protection class	see connector selection page 7	

Operating temperature range at valve -20°C to +115°C

ED - Electro-hydraulic pressure control for A10VO series 5x

The max. pump output pressure is set through a command current signal to the ED-valve solenoid

When system pressure (load pressure) reaches this pressure level, the pump's control valve spool shifts and causes an increase or decrease in the pump's swivel angle (flow) in order to maintain this set pressure level.

The pump output flow matches the needed input flow to the actuators. The desired pressure level can be set steplessly by varying the solenoid current.

When the solenoid current signal drops towards a zero value, the max. output pressure is limited by an adjustable mechanical pressure cut off (secure fail safe function in case of a loss of power e.g. for use as fan drives).

Schematic A10VO...ED../5x

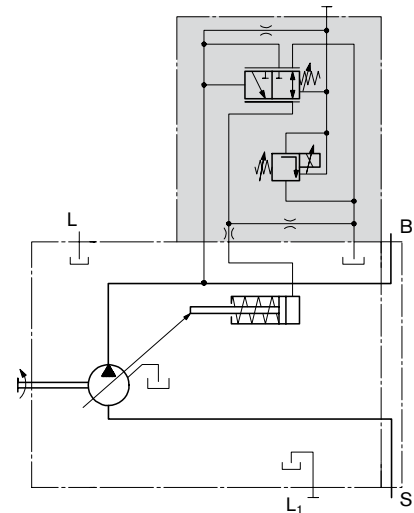

Static current-pressure characteristic (inverse proportional characteristic)

(measured at pump in standby)

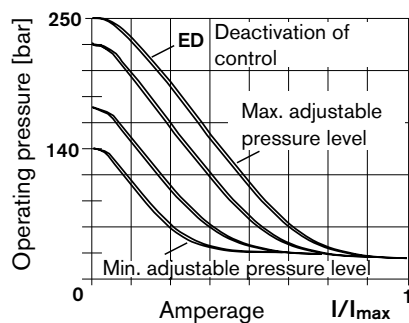

Hysteresis of static current-press. characteristic < 3bar

Ports

- B Pressure port
- S Suction port
- L, L₁ Case drain port (L₁ plugged)

Pilot flow consumption: 3 - 4,5 L/min.

Static flow-pressure characteristic

(at n= 1500rpm; t_{fluid} = 50°C)

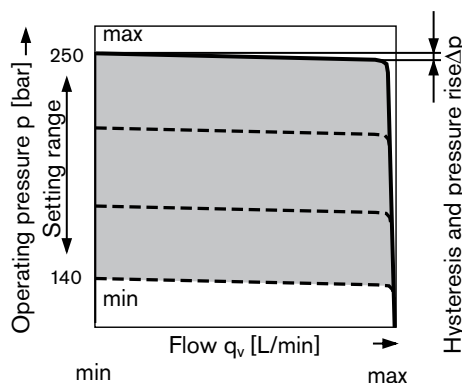

Control data

Standard setting of standby 20bar, other values on request.

Hysteresis and pressure rise $\Delta p < 4$ bar.

Technical data, solenoids	ED71	ED72
Voltage	12 V (± 20 %)	24 V (± 20 %)
Control current		
Begin of control at $q_{v \min}$	100 mA	50 mA
End of control at $q_{v \max}$	1200 mA	600 mA
Limit current	1,54 A	0,77 A
Nominal resistance (at 20°C)	5,5 Ω	22,7 Ω
Dither frequency	100 - 200 Hz	100 - 200 Hz
Duty cycle	100 %	100 %
Solenoid class of material	H ($T_{\max} = 180^\circ\text{C}$)	
Protection	see connector selection page 7	

Operating temperature range at valve -20°C to +115°C

Dimensions A10V(S)O series 3x

Before finalising your design please request a certified installation drawing.
Dimensions in mm

Valve mounting on port plate 11 and 61

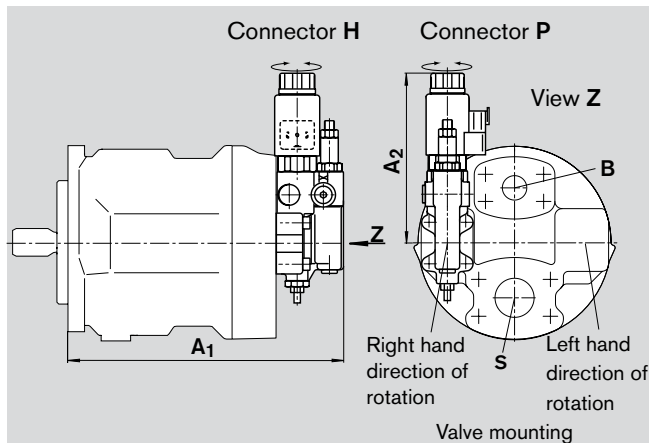

Dimensions series 31

for port plate 11/61 and 12/62

Size	A ₁	A ₂	A ₃	A ₄
18	–	–	126	140
28	255	143	136	140
45	244	140	146	140
71	278	140	160	140
100	344	140	165	140
140	349	138	179	129

Dimensions series 32

for port plate 11/61 and 12/62

Size	A ₁	A ₁	A ₂	A ₃	A ₄
Mounting flange					
B C/D					
71	288	291	140	160	140
100	338	342	140	165	140
140	358	362	138	179	129

For detailed dimensions and technical data on the variable pump see data sheet A10VSO 18 RE 92712, A10VSO 28...140 RE 92711; 92714 and A10VO 18...140 RE 92701.

Further information can be found under „Solenoid connectors“ on page 7

Valve mounting on port plate 12 and 62

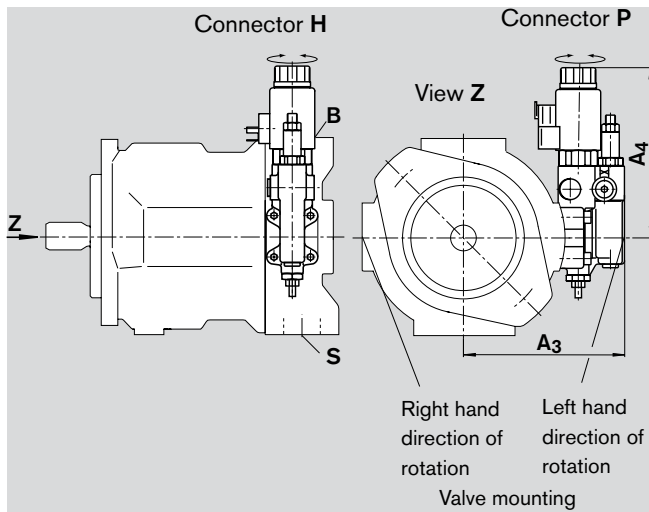

Dimensions A10VO series 5x

A10VO...ED/5x

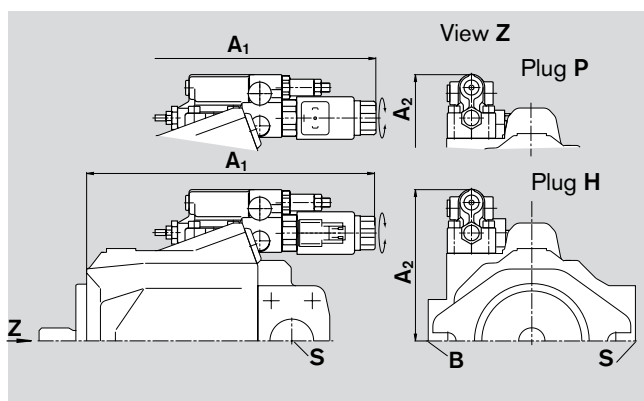

Dimensions series 52

Size	A ₁	A ₂
28	240	124
45	250	132
63	250	137
85	272	156

Dimensions series 53

Size	A ₁	A ₂
18	213	121,9

For detailed dimensions and technical data on the variable pump see data sheet A10VO RE 92703.

Further information can be found under „Solenoid connectors“ on page 7

Solenoid connectors

DEUTSCH DT04-2P-EP04, 2-pole

permanently moulded, without bi-directional suppressor diode (standard) _____ P

Protection to DIN/EN 60529: IP69K

Male plug

DEUTSCH DT06-2S-EP04
Rexroth Mat.-Nr. R902601804

comprising: _____ DT-Identification
 – 1 Housing _____ DT06-2S-EP04
 – 1 Key _____ W2S
 – 2 Bushings _____ 0462-201-16141

The male plug is not included in the scope of supply.
This can be delivered by Rexroth on request.

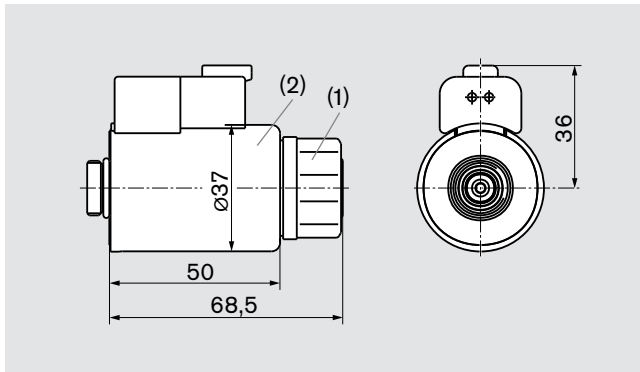

HIRSCHMANN DIN EN 175 301-803-A /ISO 4400 (not for new applications)

without bi-directional suppressor diode _____ H

Protection to DIN/EN 60529: IP65

The cable joint sealing ring is suitable for cable diameters from 4,5 mm to 10 mm .

The HIRSCHMANN-connector is included in the supply of the pump.

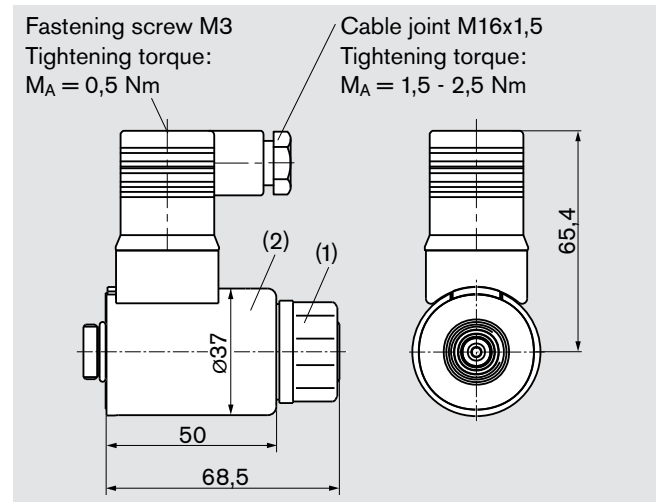

Note:

Plug orientation can be changed by rotation of the solenoid body.

Please observe the following procedure:

- 1. Loosen the fastening nut (1)
- 2. Rotate the solenoid body (2) into the desired orientation
- 3. Retighten fastening nut
Tightening torque: 5^{+1} Nm
(wrench size across flats SW26, 12kt DIN 3124)

Electronic controls

Control	Electronic function	Electronics		Further information
		RA	analogue	
Electric pressure control	Regulated current output	VT2000	analogue	RE 29 904
		RC2-2/21 ¹⁾	digital	RE 95 201

¹⁾ Current outputs for 2 valves, separately controllable

General information

- The pump A10V(S)O was designed for operation in open loop circuits.
- Systems design, installation and commissioning requires trained technicians or tradesmen.
- All hydraulic ports can only be used for the fastening of hydraulic service lines.
- During and shortly after operation of a pump the housing and especially a solenoid can be extremely hot. Take suitable safety measures (e.g. wear protective clothing).
- All given data and information has to be adhered to.
- Regarding the tightening torques the following must be observed:
 - Female threads in the axial piston unit:
 - The max. permissible tightening torques $M_{G_{max}}$ are maximum values for the female threads and may not be exceeded
- Fittings:
Please comply with the manufacturer's information regarding the max. permissible tightening torques for the used fittings.
- Fastening screws:
For fastening screws to DIN 13 we recommend to check the permissible tightening torque in each individual case acc. to VDI 2230.